

59615

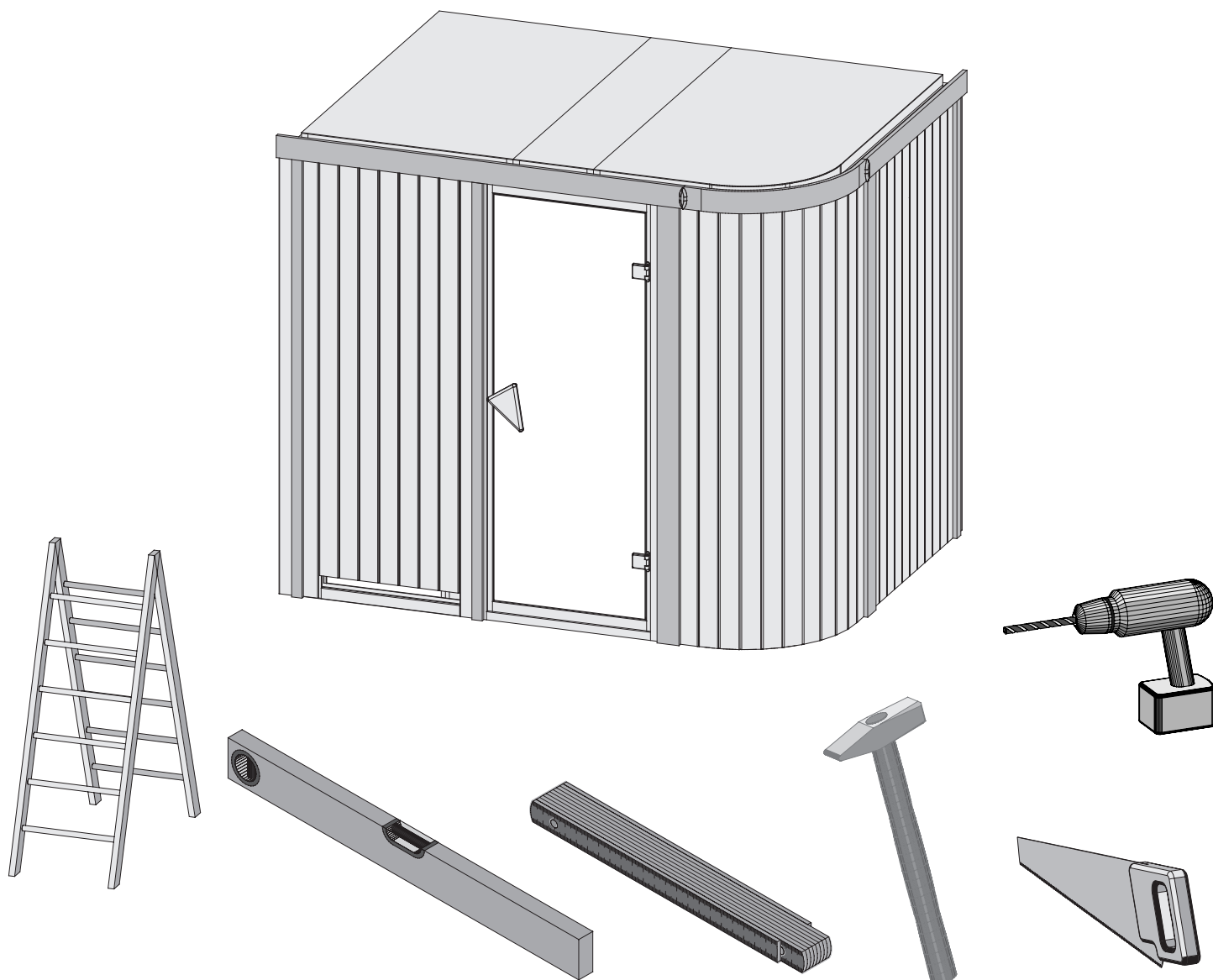

 **Aufbauanleitung**

 **notice de montage**

 **Building Instructions**

 **montagehandleiding**

 **Instrucciones de construcción**

 **Istruzioni per il montaggio**

 **Service-Hotline: +49 421 38693 33**



Vergleichen Sie zuerst die Materialliste mit Ihrem Paketinhalt! Bitte haben Sie Verständnis, dass Beanstandungen nur im nicht aufgebauten Zustand bearbeitet werden können!



Commencez par comparer la liste du matériel avec le contenu de votre paquet! Sachez que nous traitons uniquement les réclamations concernant le matériel à l'état non monté!



First compare the list of materials with your package contents! Please understand that complaints can be processed in the non-built status only!



Vergelijk eerst de lijst van materialen met de inhoud van uw pakket! Reclamaties kunnen alleen in behandeling worden genomen zolang de onderdelen nog niet zijn gemonteerd!



En primer lugar, compare la lista de material con el contenido del paquete. Rogamos entienda que las reclamaciones sólo pueden ser tramitadas antes de montar el objeto!



Confrontate questa distinta materiali prima con il contenuto del pacchetto! Vi preghiamo di comprendere che eventuali reclami possono essere accolti solo prima del montaggio!



59615

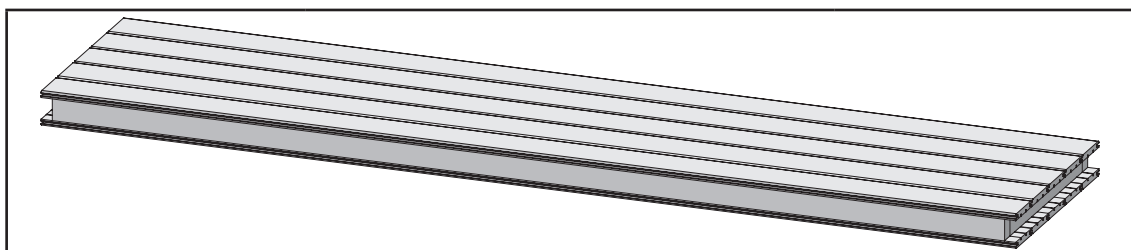

1 x W1

1920 x 950 x 68mm

ID 24766

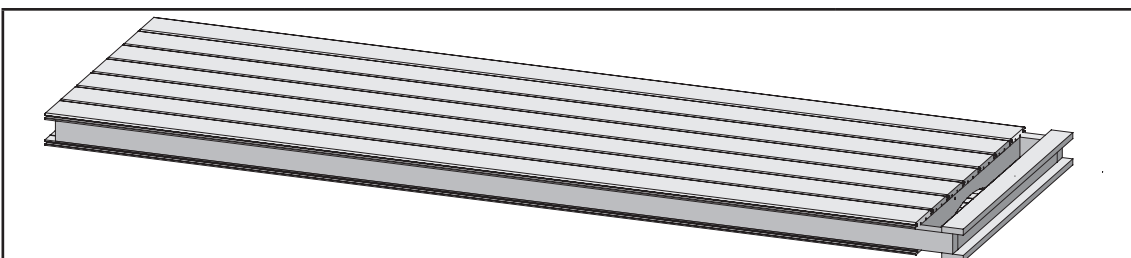

1 x W2

1920 x 780 x 68mm

ID 24677

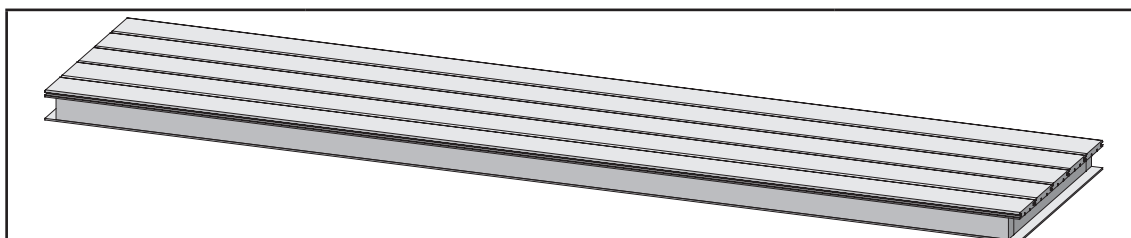

4 x W3

1920 x 780 x 57mm

ID 23625

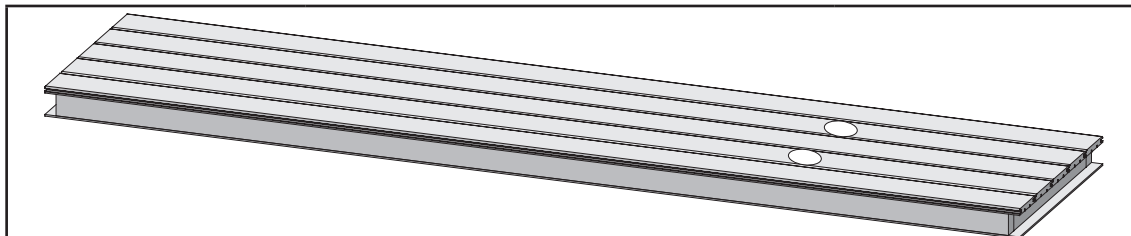

1 x W4

1920 x 606 x 57mm

ID 23629

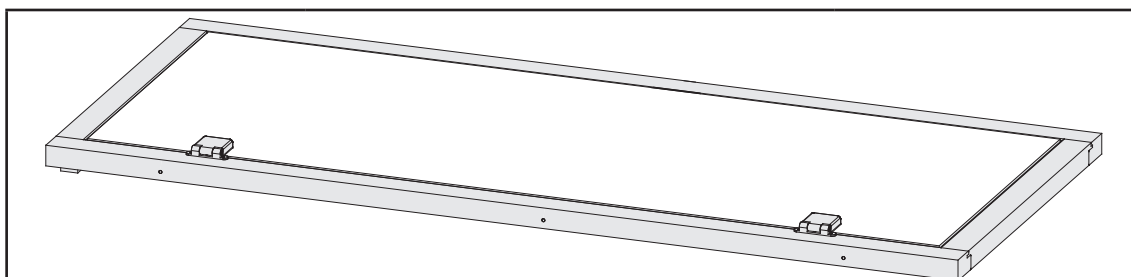

1 x W5

1872 x 780 x 42mm

ID 25551

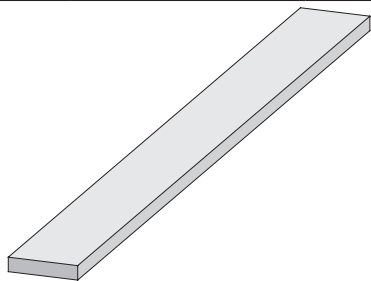

6 x B1	1920 x 19 x 3mm	ID 20799
4 x B2	750 x 35 x 12mm	ID 24239
4 x B3	1920 x 35 x 12mm	ID 24846
4 x B4	70 x 45 x 18mm	ID 26366
4 x B5	800 x 45 x 18mm	ID 24796
3 x B6	1884 x 45 x 18mm	ID 48037
4 x B7	480 x 95 x 18mm	ID 20930
4 x B8	580 x 95 x 18mm	ID 16708
1 x B9	1160 x 95 x 18mm	ID 49855
1 x B10	1770 x 95 x 18mm	ID 15984
2 x B11	1884 x 95 x 18mm	ID 24179
1 x B12	300 x 120 x 18mm	ID 22467
2 x B13	590 x 42 x 28mm	ID 26360
2 x B14	945 x 42 x 28mm	ID 26279
1 x B15	1013 x 42 x 28mm	ID 25750
2 x B16	1198 x 42 x 28mm	ID 60120
1 x B17	1555 x 42 x 28mm	ID 24130
1 x B18	1593 x 42 x 28mm	ID 52819
2 x B19	1666 x 42 x 28mm	ID 26377
2 x B20	1763 x 42 x 28mm	ID 60121
1 x B21	2107 x 42 x 28mm	ID 52818
2 x B22	2189 x 42 x 28mm	ID 24128
3 x B23	1874 x 52 x 52mm	ID 26165



1 x D3 | 936 x 95 x 18mm | ID 52671

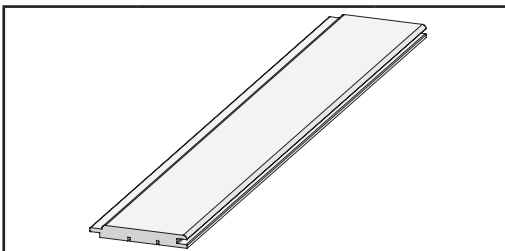

2 x E1 | 1920 x 97 x 12mm | ID 22863

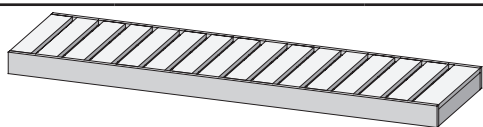

2 x L1 | 2156 x 550 x 90mm | ID 21768

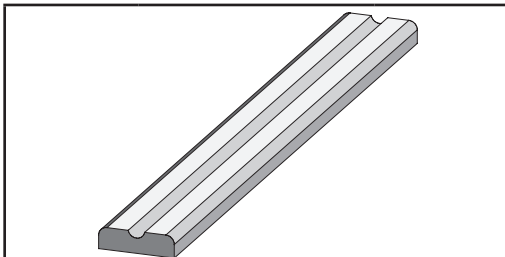

2 x L2 | 2156 x 90 x 22mm | ID 26390

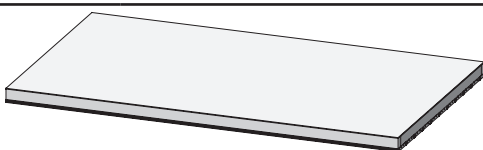

1 x M1 | 1582 x 349 x 57mm | ID 49470
1 x M2 | 1582 x 918 x 57mm | ID 24795

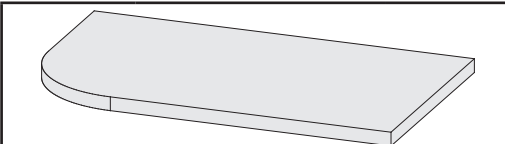

1 x M3 | 1582 x 918 x 57mm | ID 52649

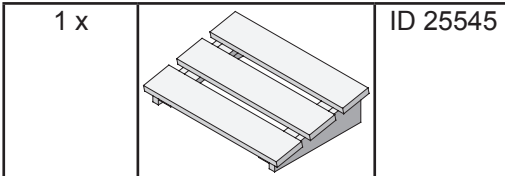

1 x | ID 25545

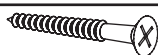

60 x	4 x 30mm	ID 3686
60 x	4 x 50mm	ID 3688
40 x	4 x 70mm	ID 3689
70 x	4,5 x 80mm	ID 9204
20 x	6 x 60mm	ID 14014



40 x | 4,5 x 40mm | ID 26285



6 x S1 | 6 x 80mm | ID 14266



120 x S2 | 4,5 x 30mm | ID 26116
6 x S3 | 12 x 18mm | ID 46403



2 x T1 | ID 26272

10 x | ID 14005



10m | ID 14025



2 x | ID 26496

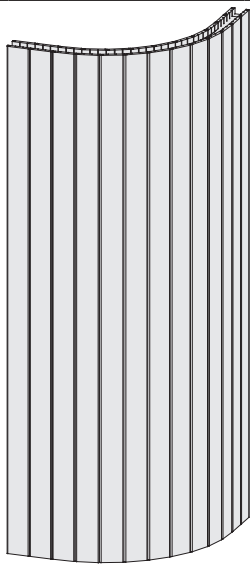
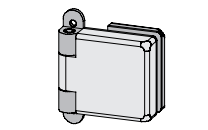
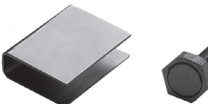
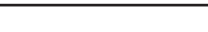

1 x C1 | ID 60112

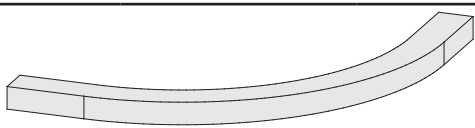

2 x D1 | 660 x 42 x 28mm | ID 60128
1 x D2 | 767 x 42 x 28mm | ID 60130

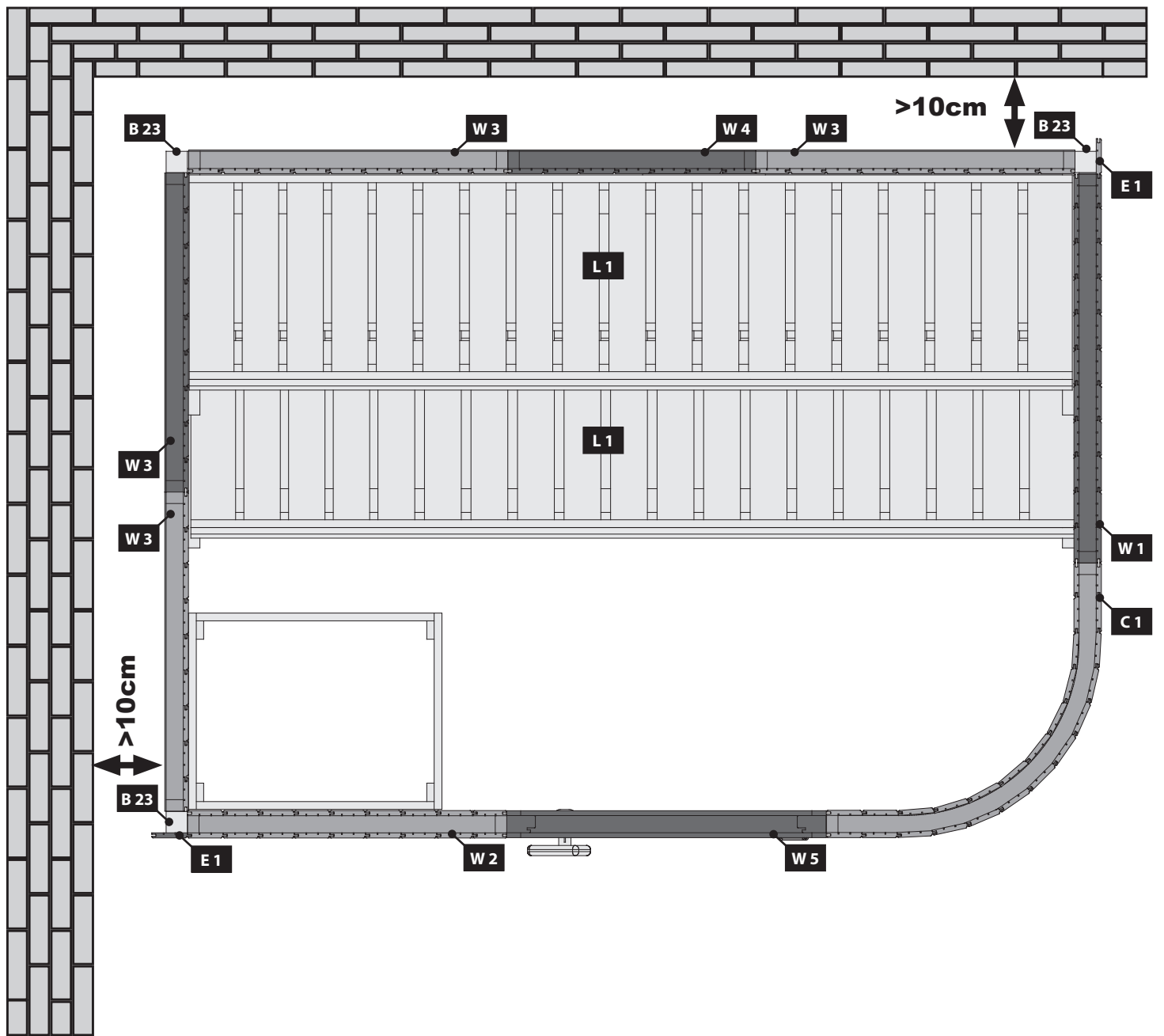

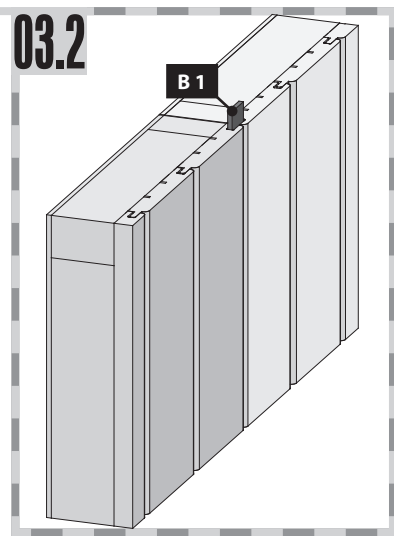
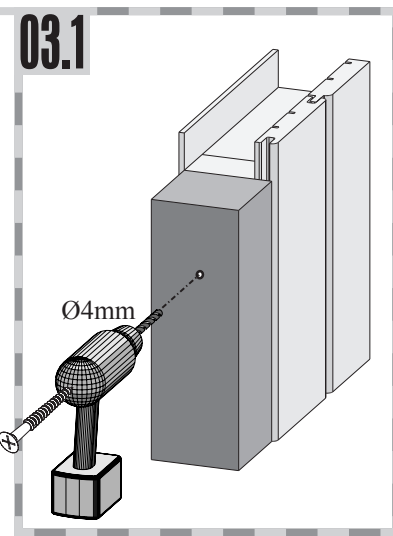
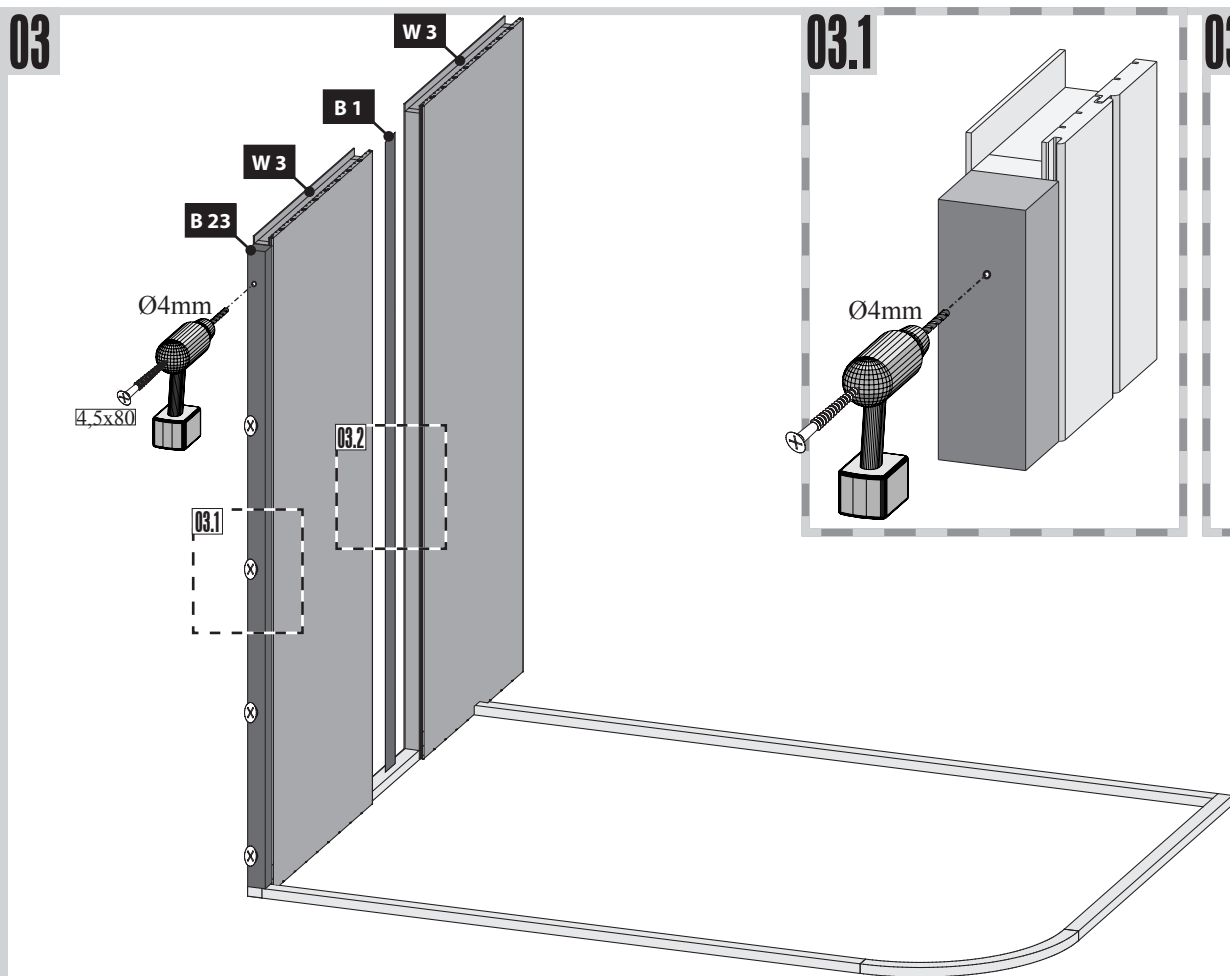
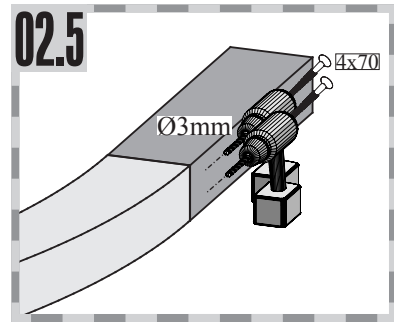
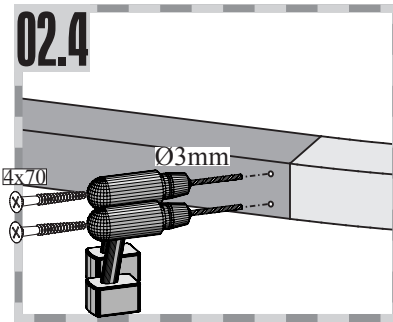
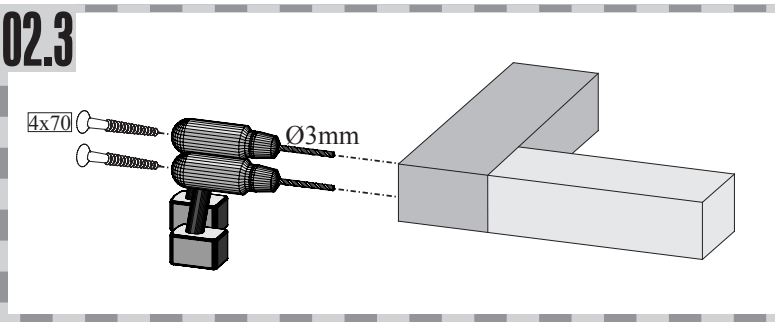
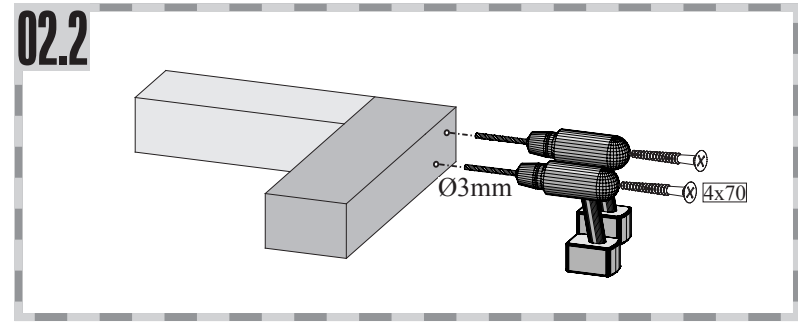
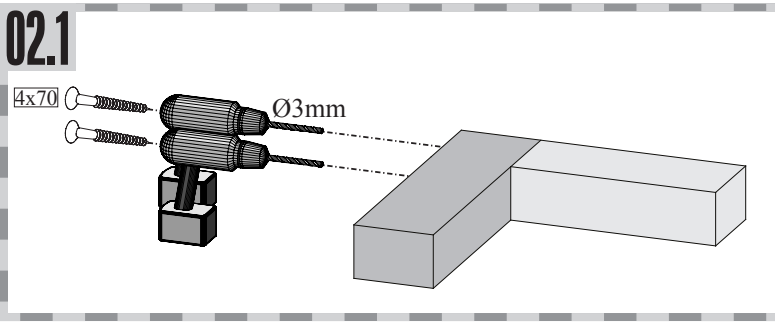
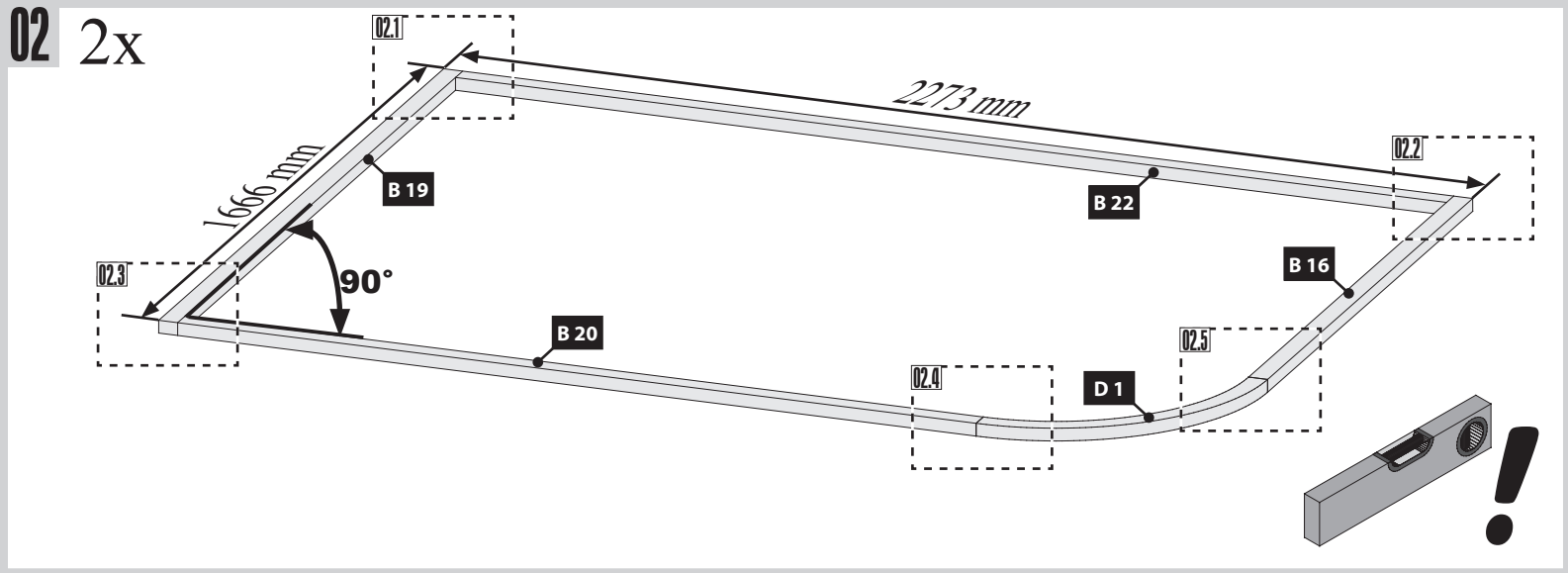

04

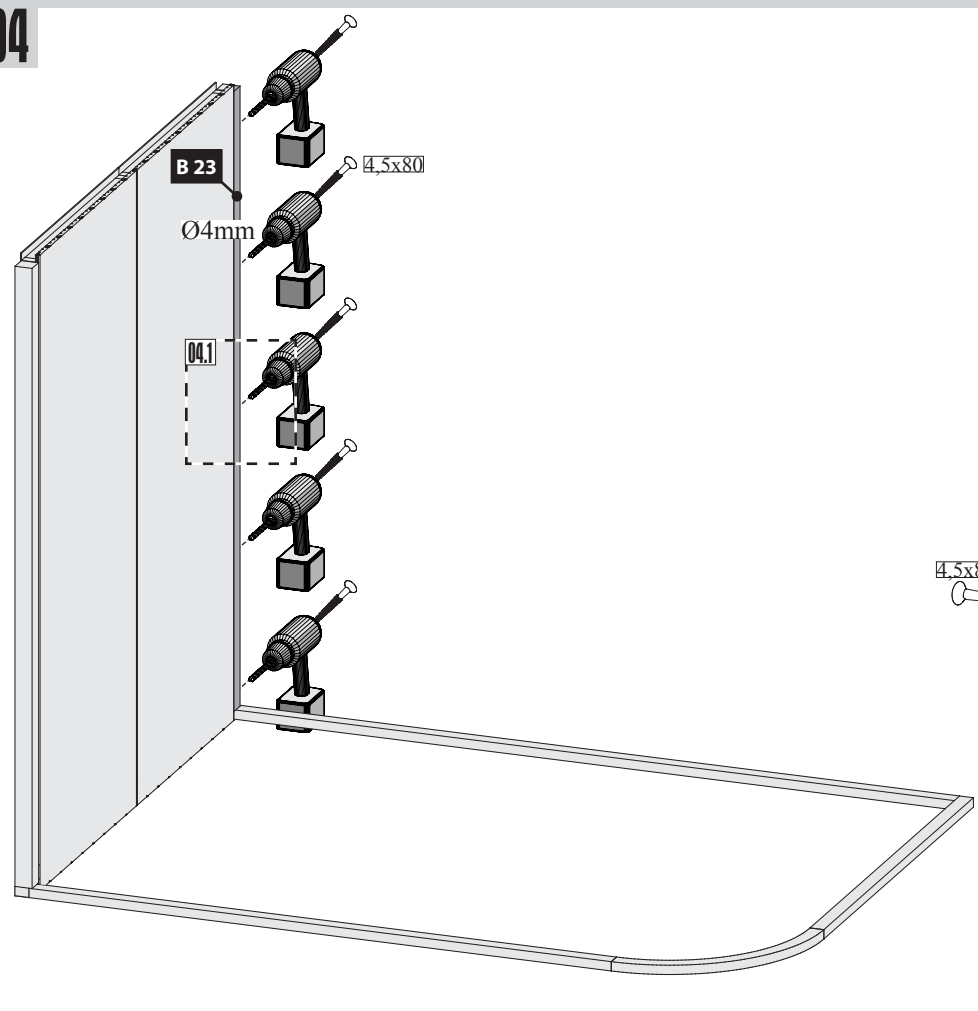

04.1

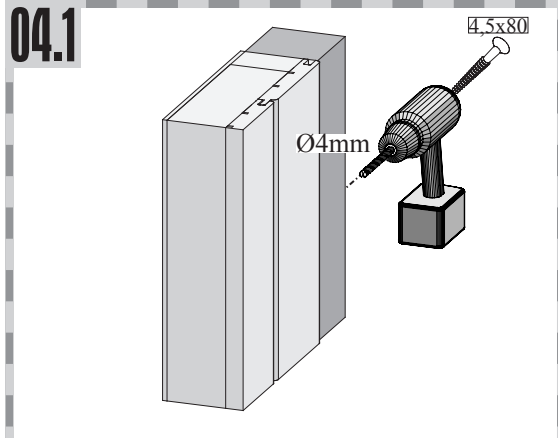

05.1

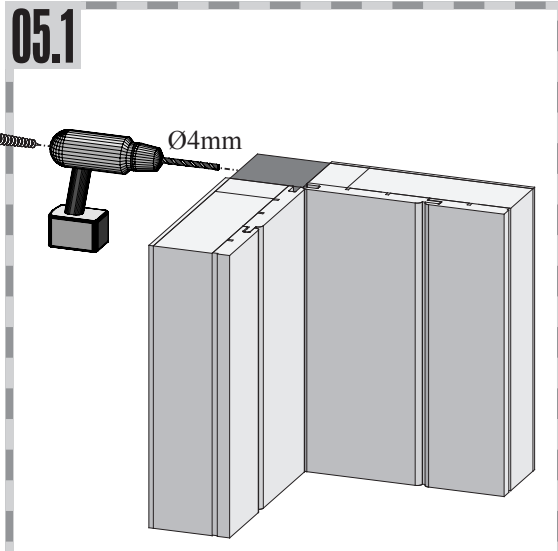

05

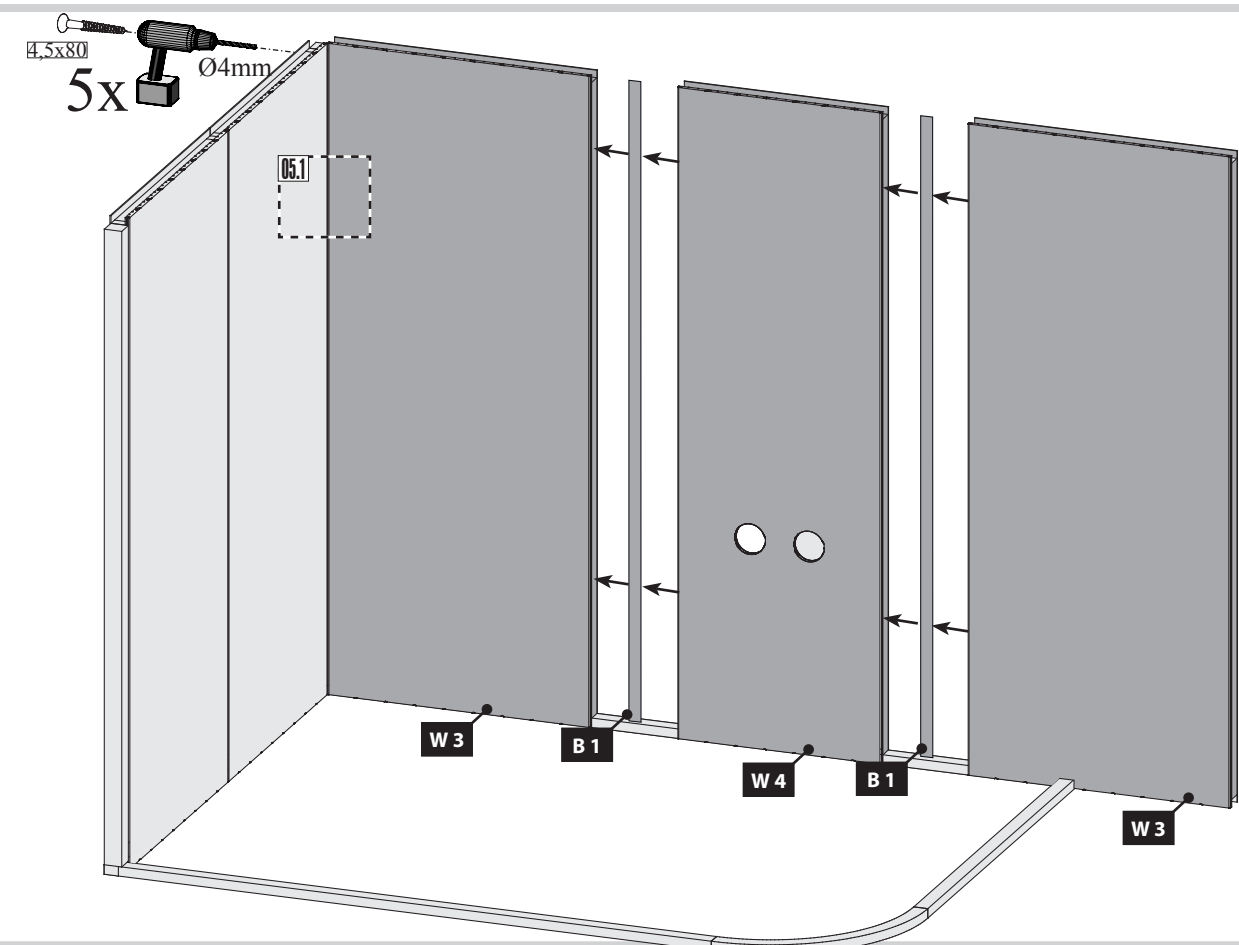

 Einbau Glastür

 Installation of glass door

 Montaje de la puerta de cristal

 Montage porte en verre

 Montage van de glazen deur

 Installazione portello di vetro

!!! 01 — 03 **!!!**

06

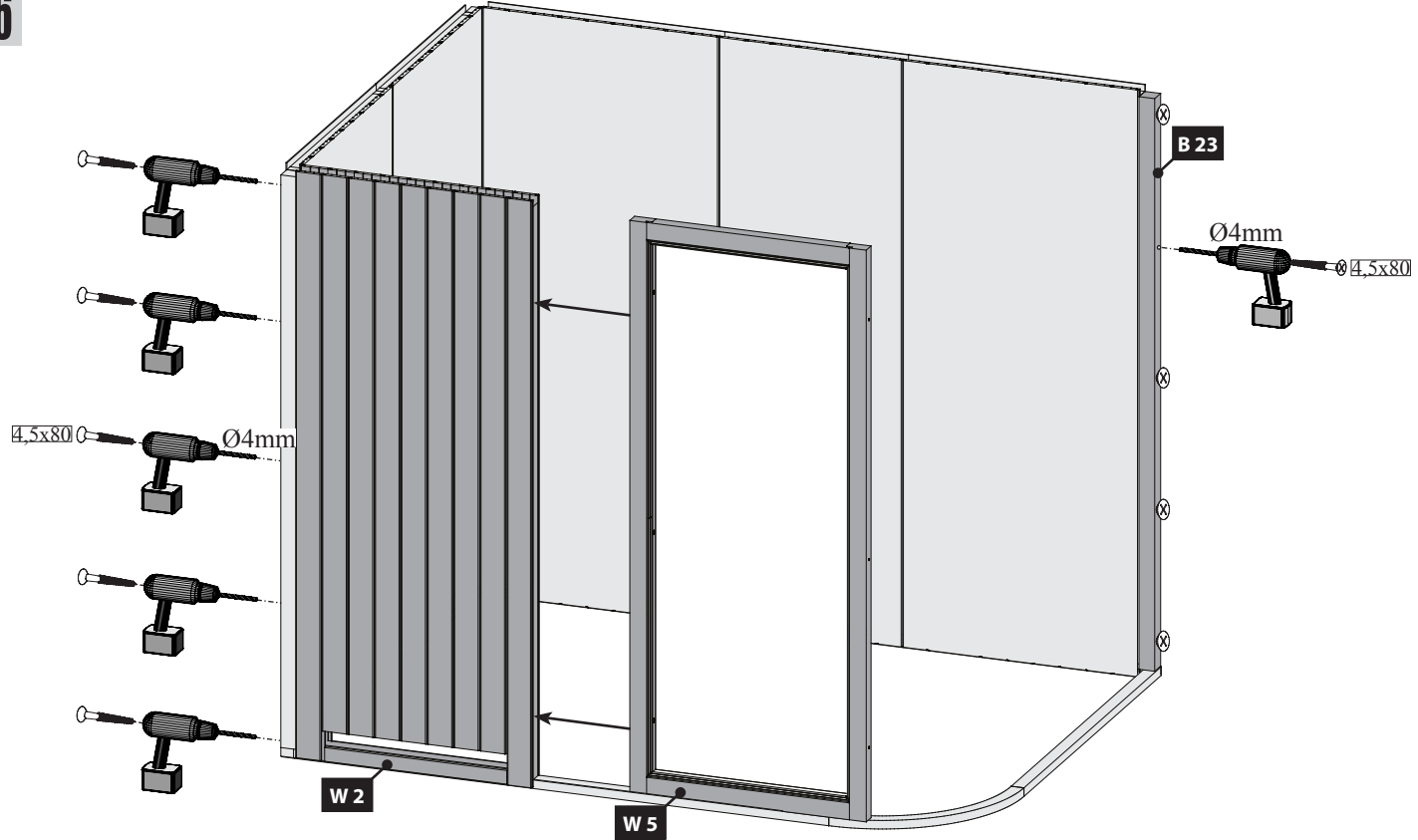

07

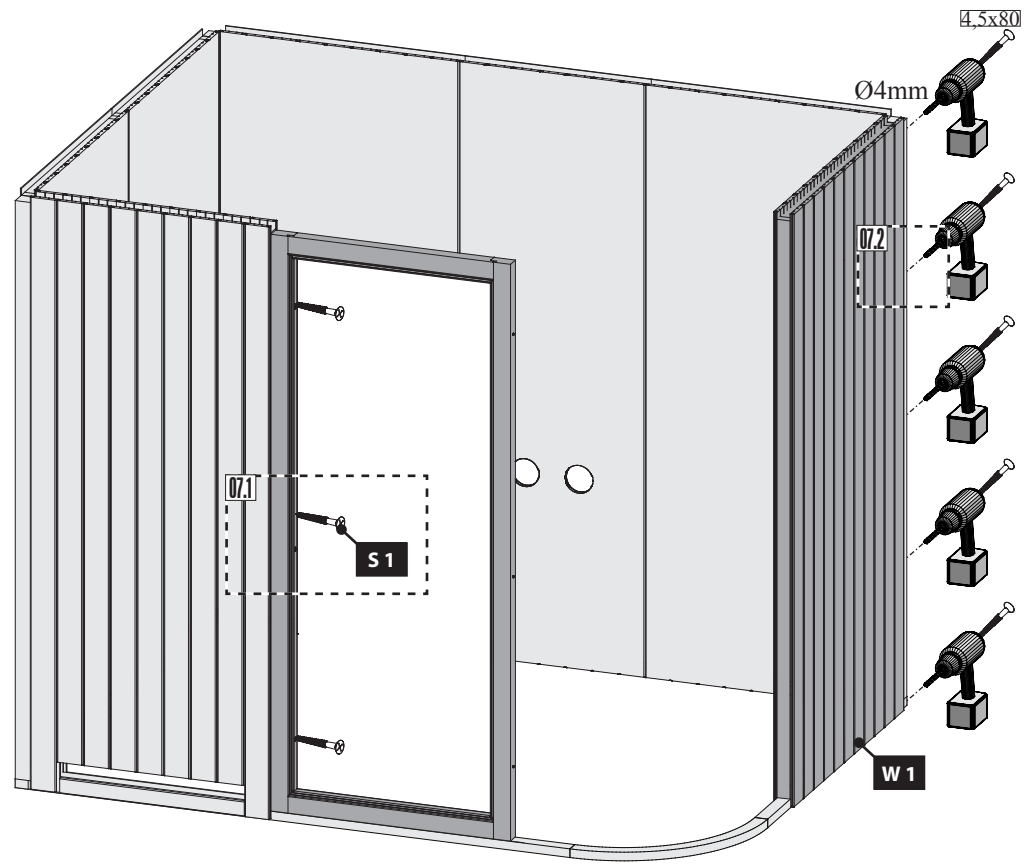

07.1

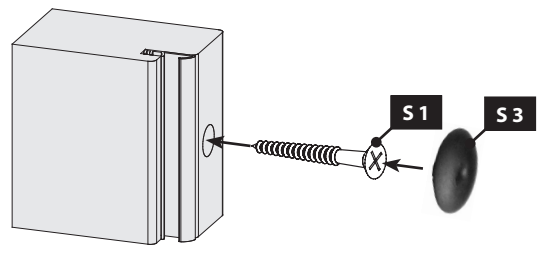

07.2

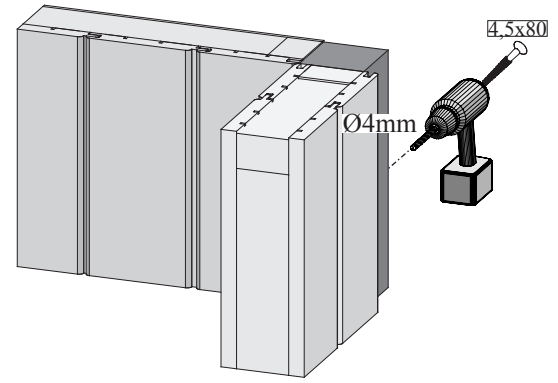

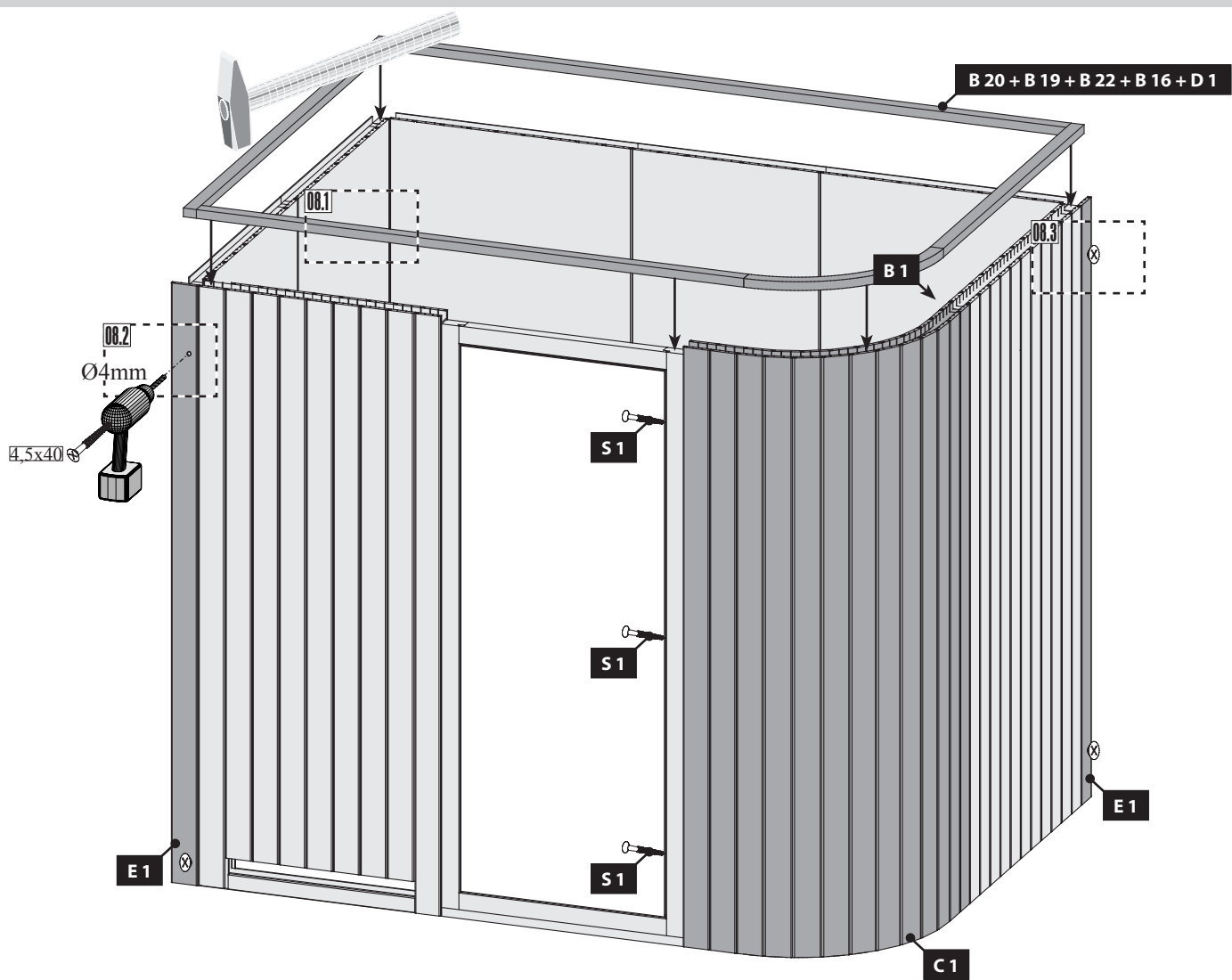

08.1

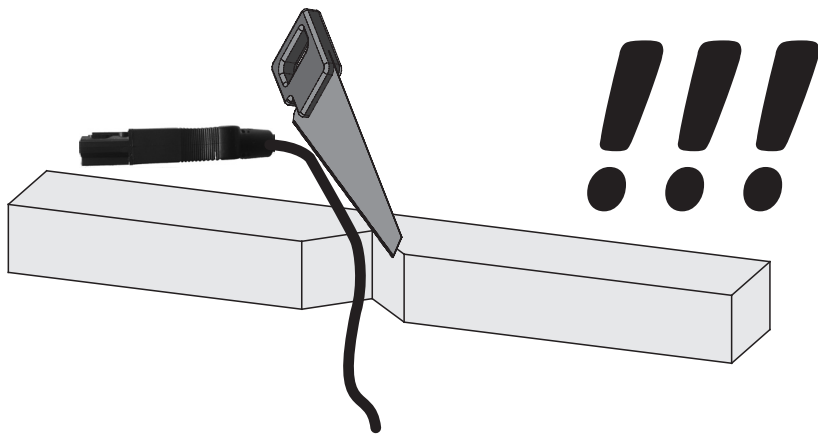

08.2

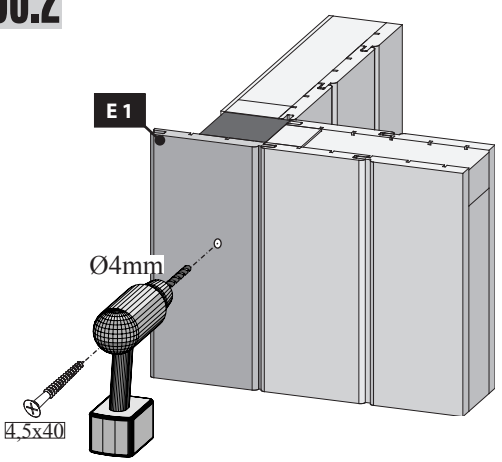

08.3

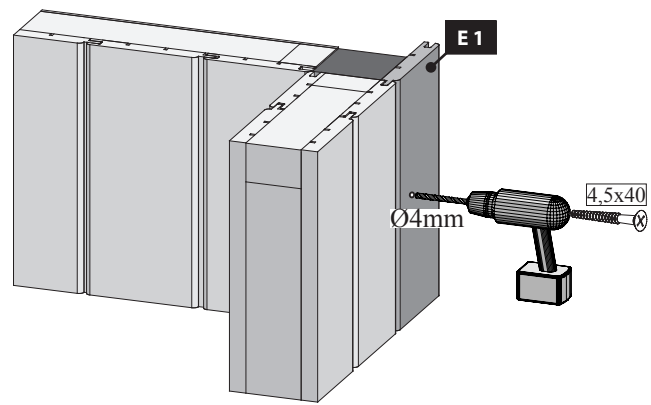

09

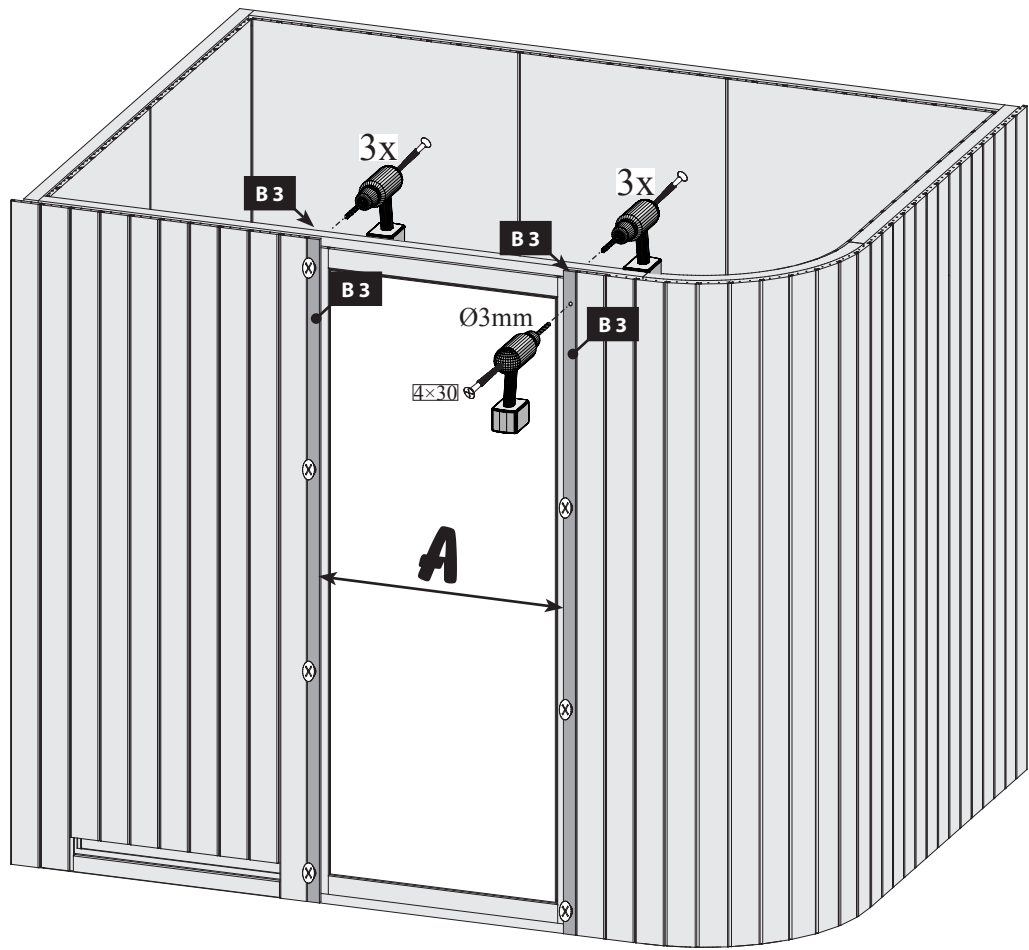

10 4x

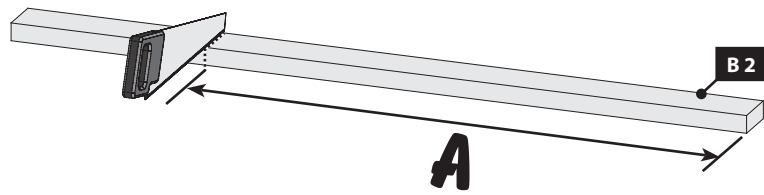

11

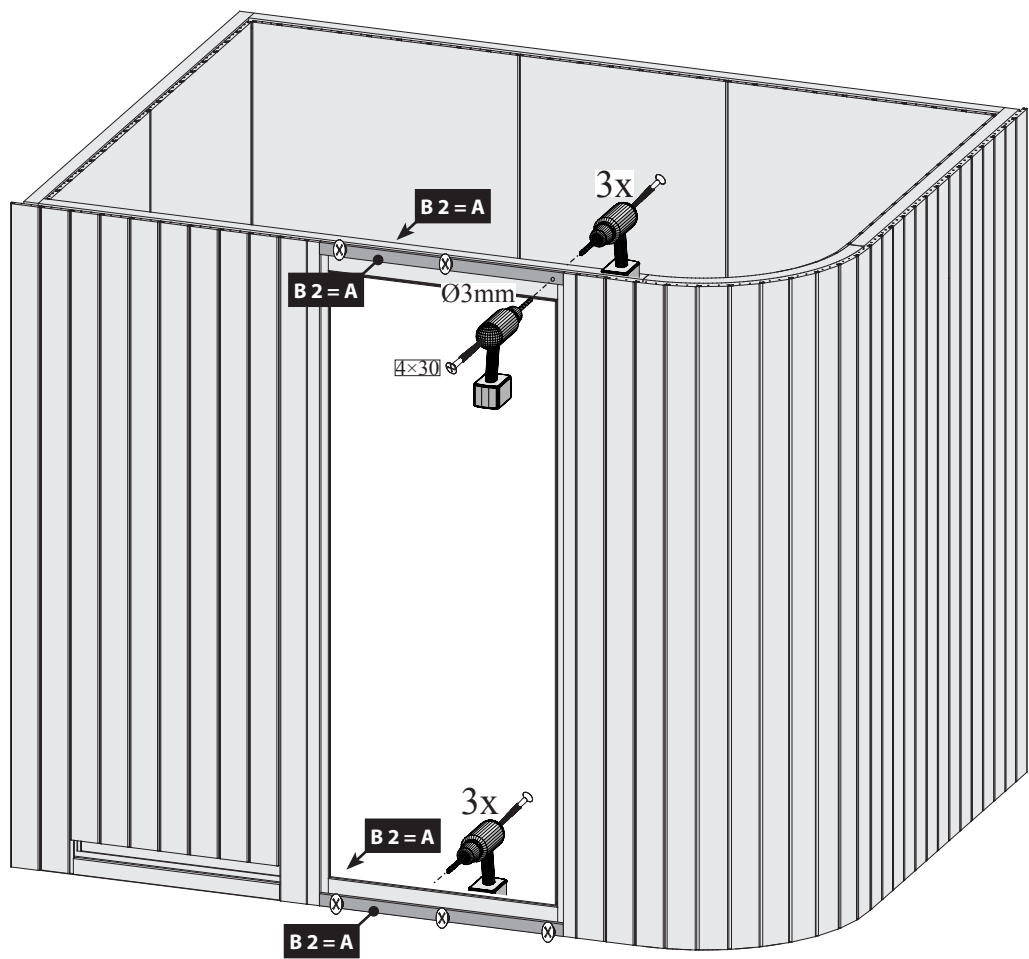

12

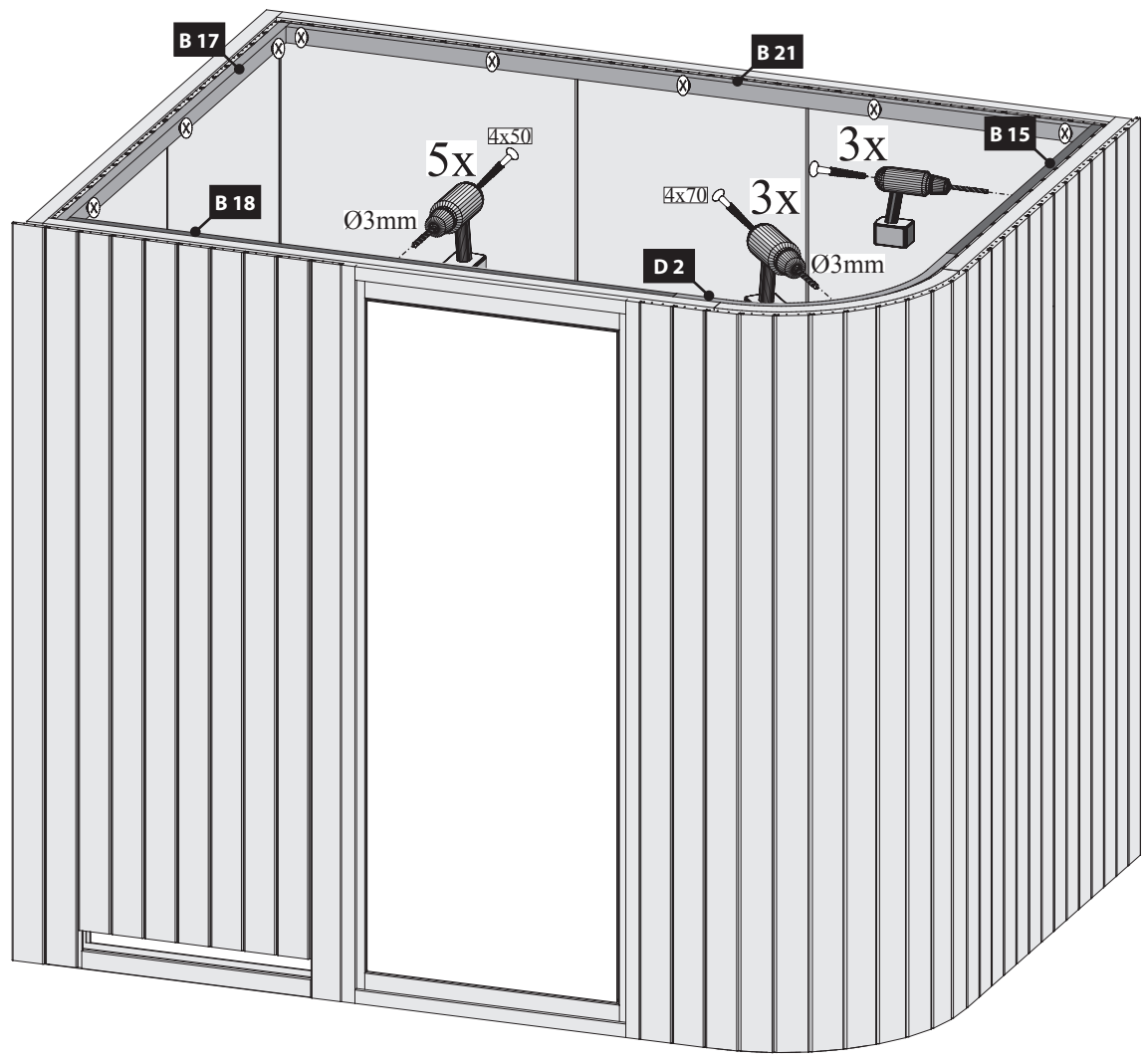

13

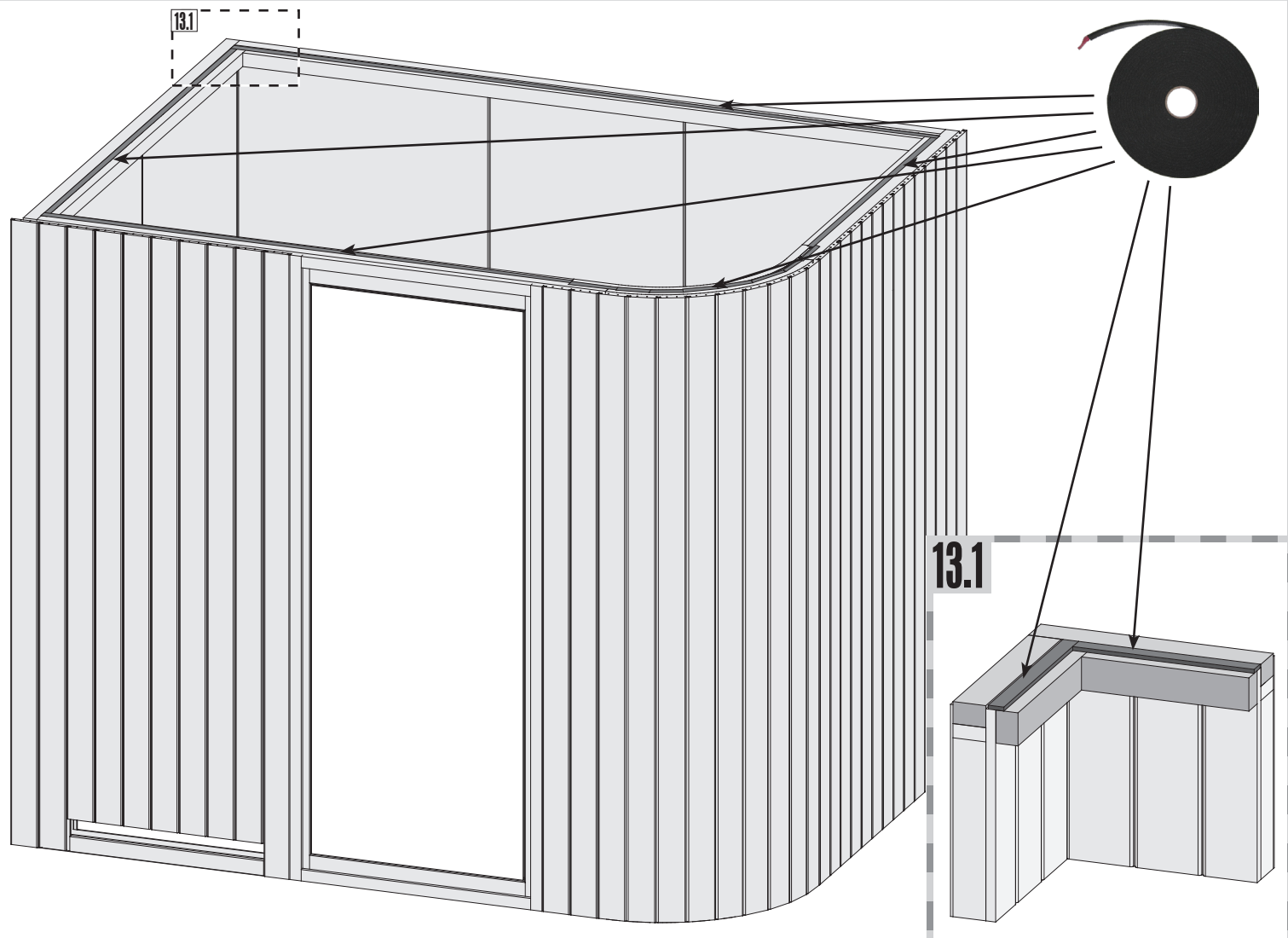

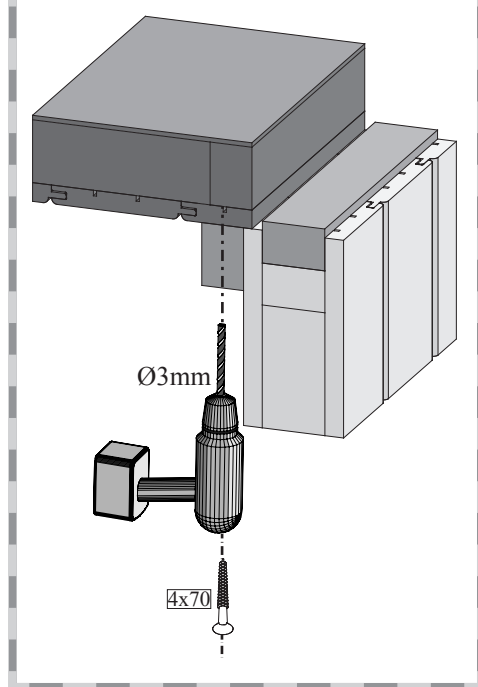
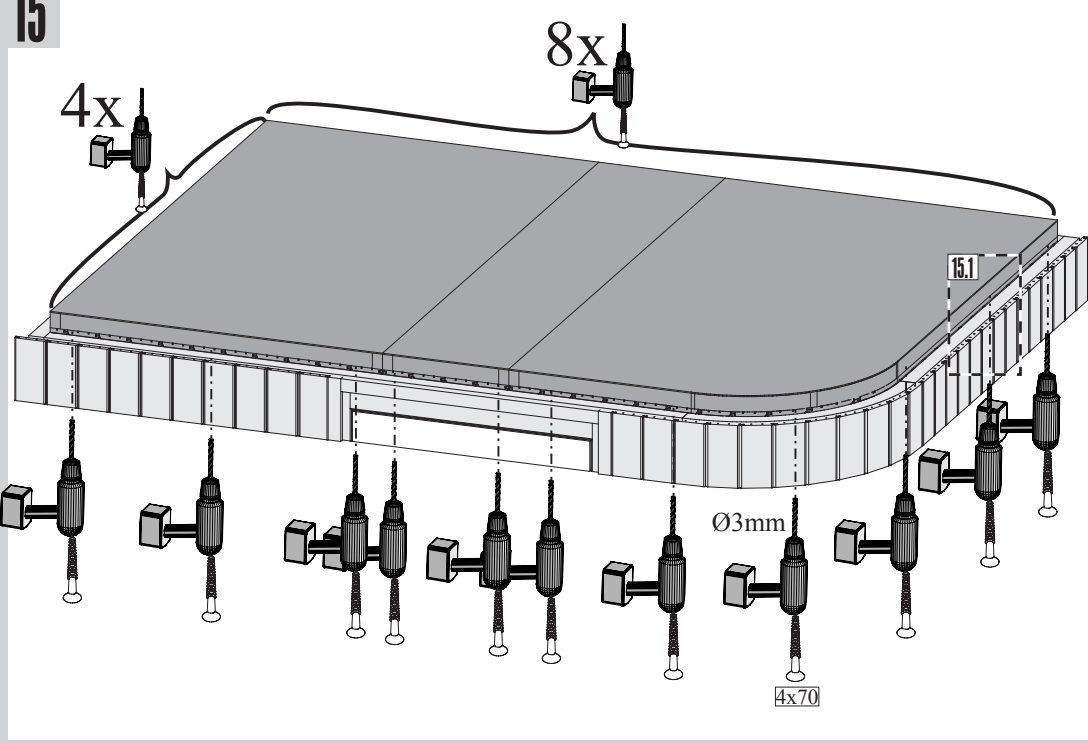
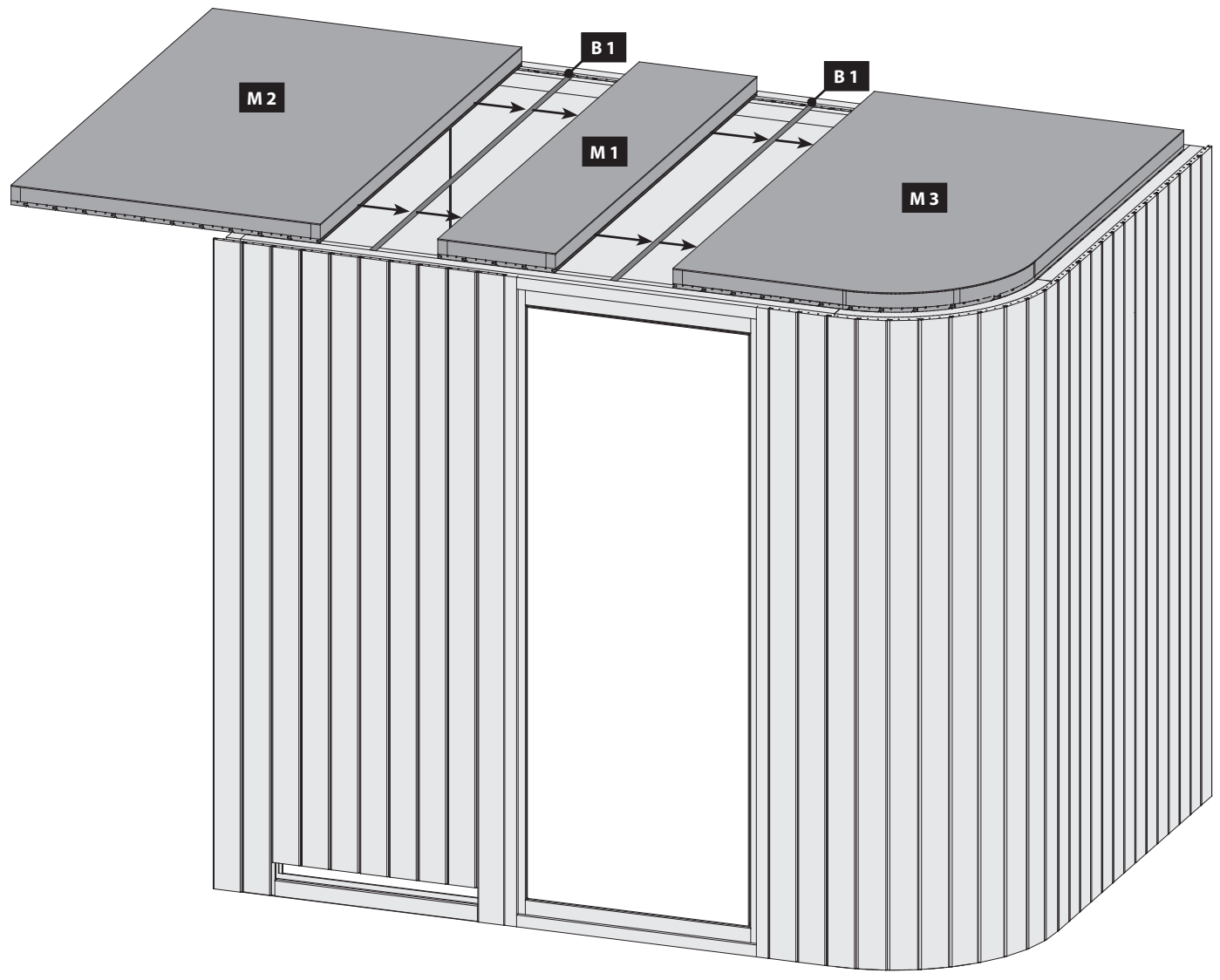

16

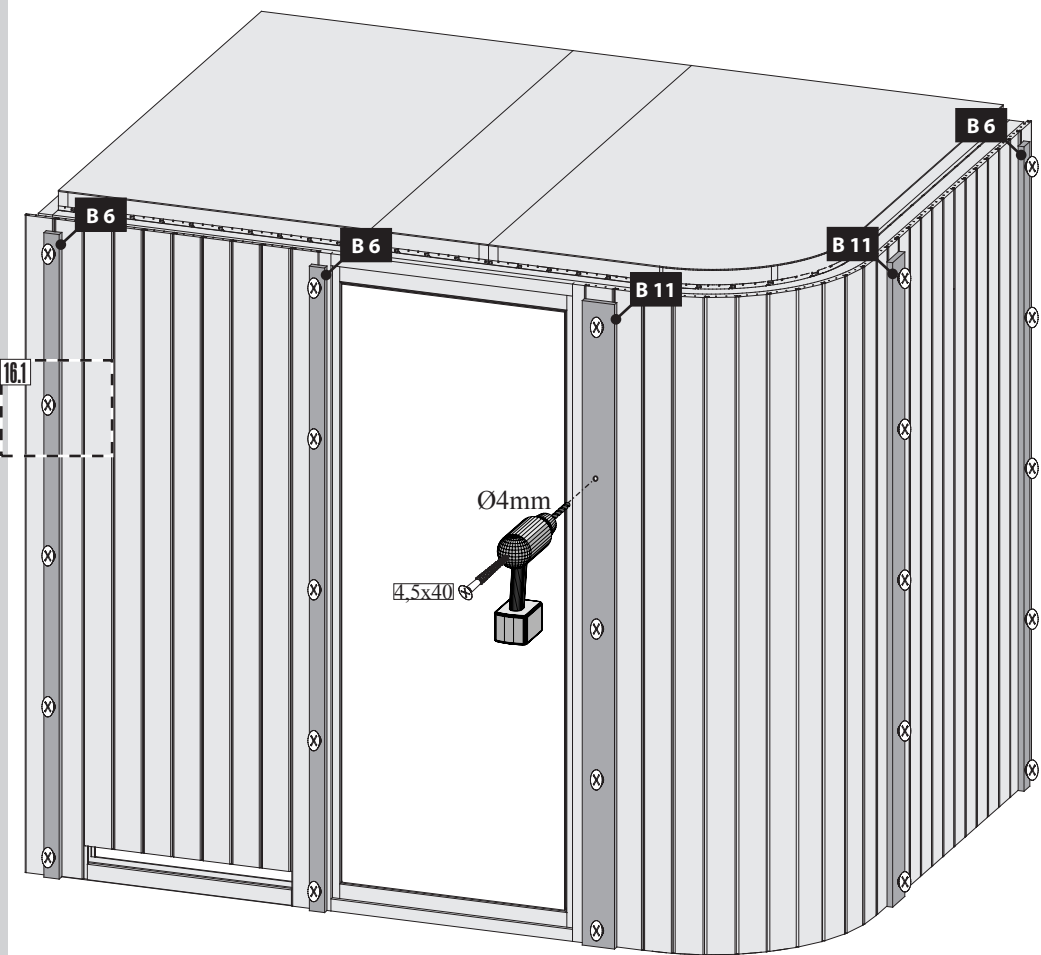

16.1

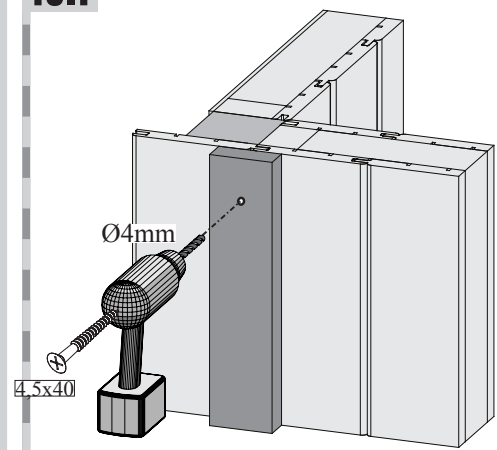

17.1

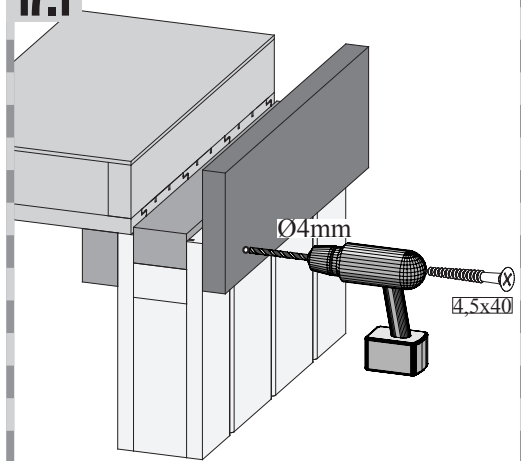

17

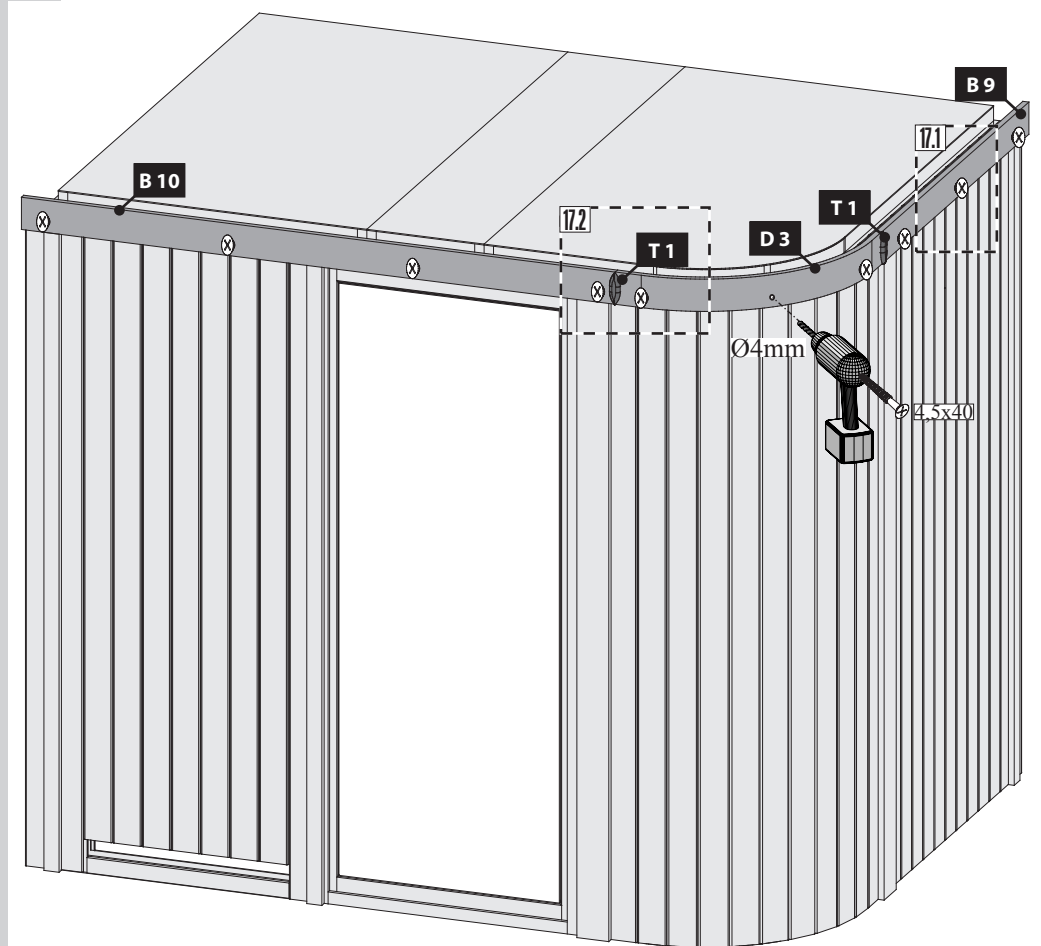

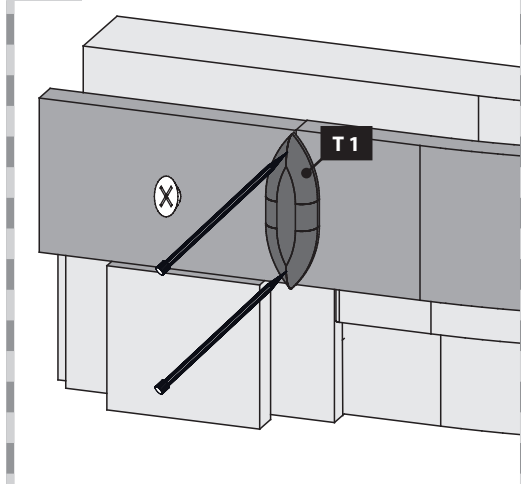

17.2



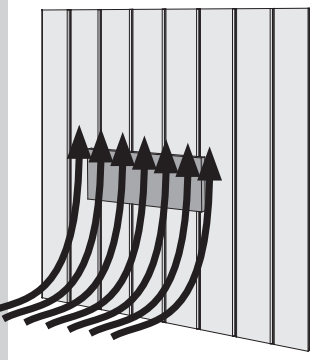
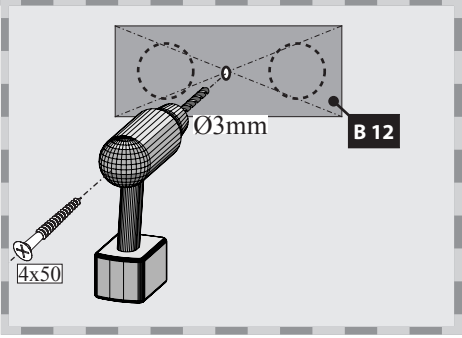
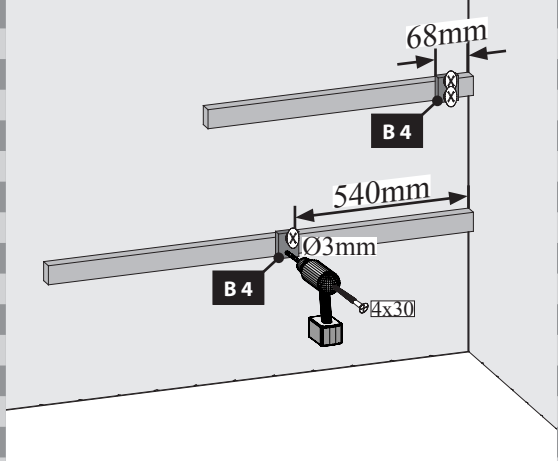
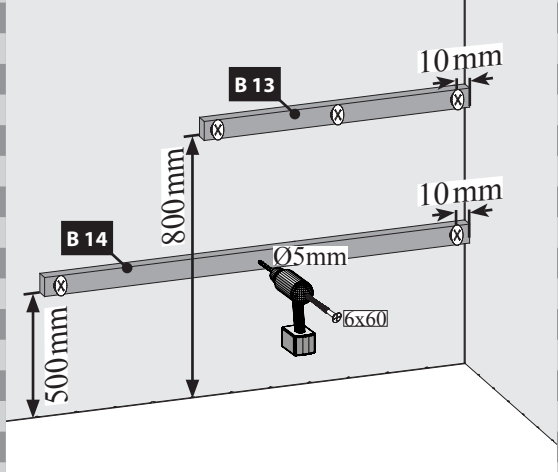
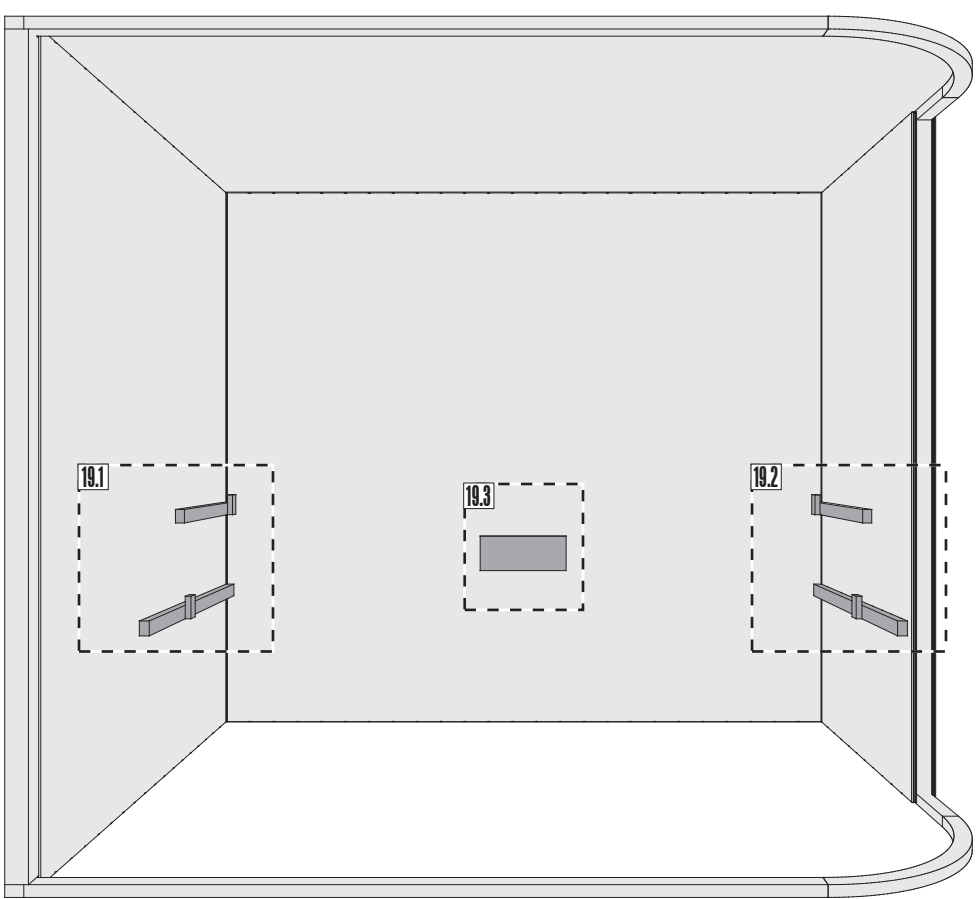

18





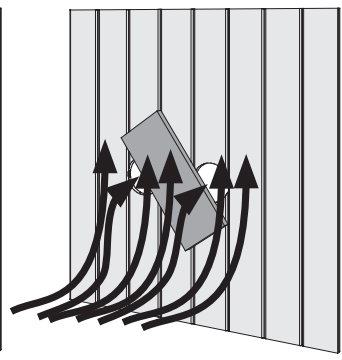

 Hier ist die Funktionsweise des Brettes abgebildet. Regeln Sie damit die Abluft nach Ihren eigenen Wünschen.



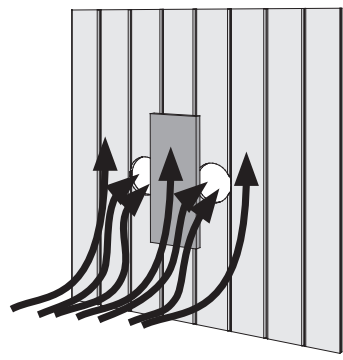

 Ceci représente le mode de fonctionnement de la planche. Avec elle, réglez l'écoulement de l'air selon vos désirs.



 This figure shows the functional principle of the board. Regulate the exhaust air according to your own wishes.

 Hier is de werking van het plankje afgebeeld. Regel daarmee de luchtafvoer naar eigen wens.

 Aquí está representada la forma de funcionamiento de la tabla. Regule con ello el aire de salida según sus propios deseos.

 Viene illustrato il principio di funzionamento della tavoletta di regolazione della ventilazione. Con essa si può regolare a piacere la ventilazione.

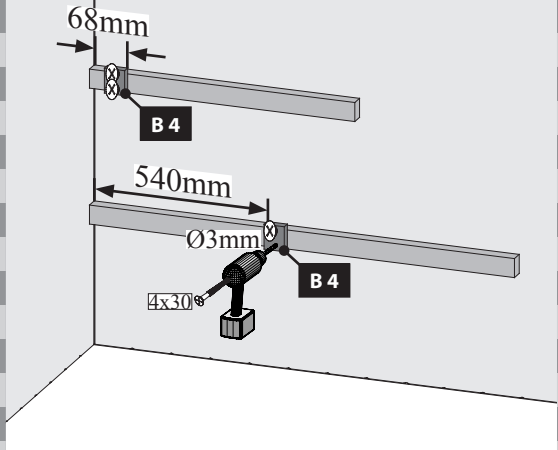
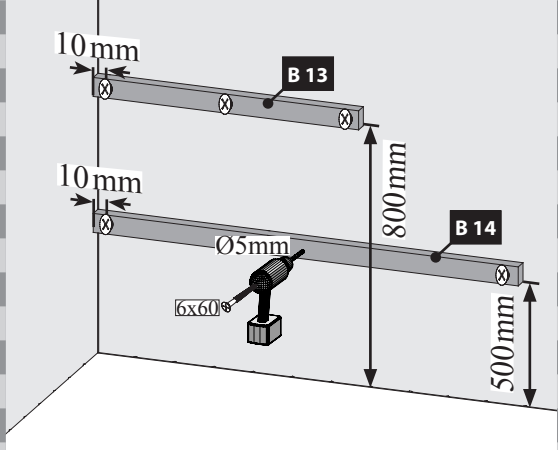

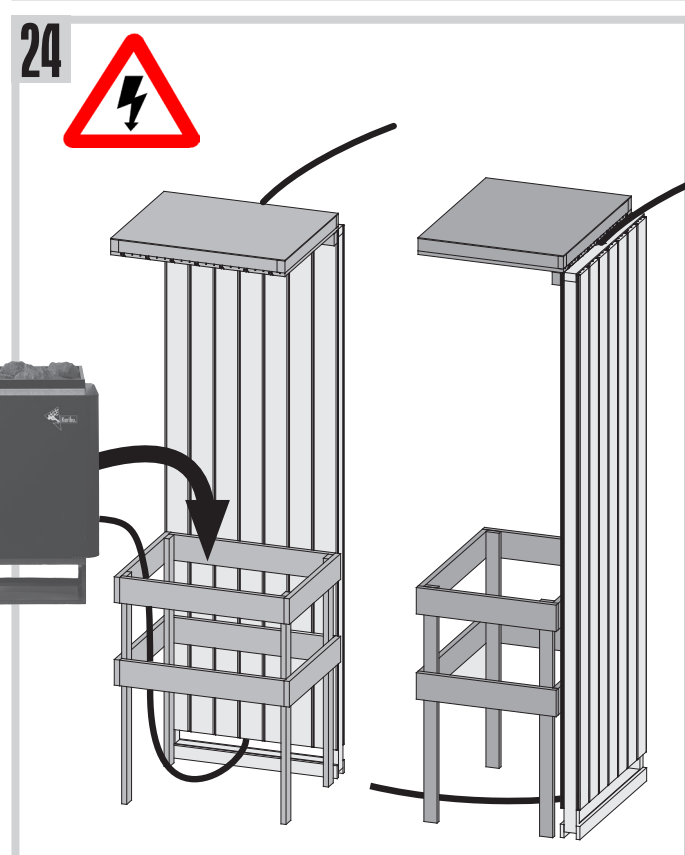
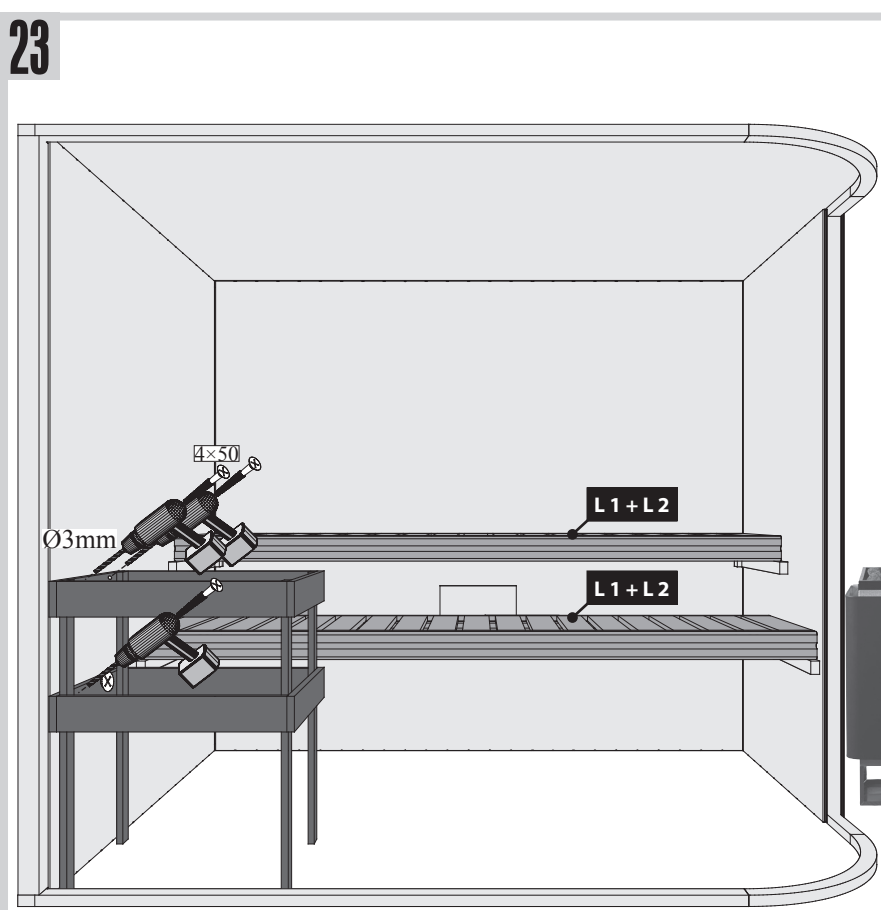
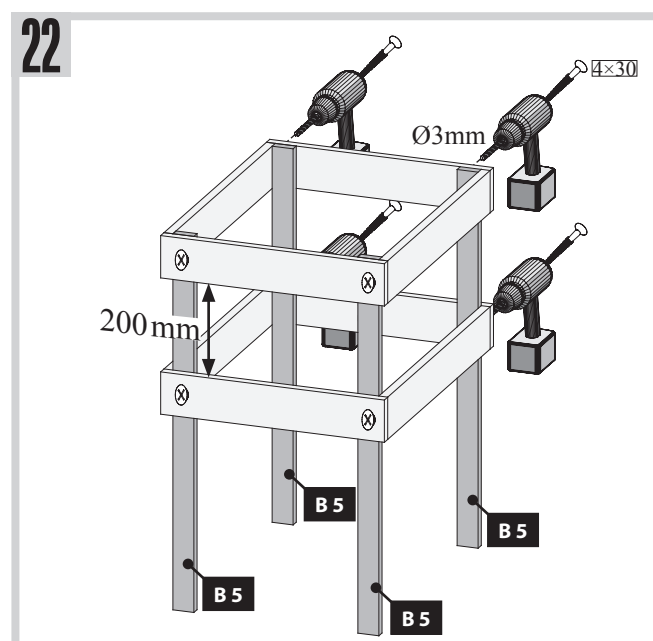
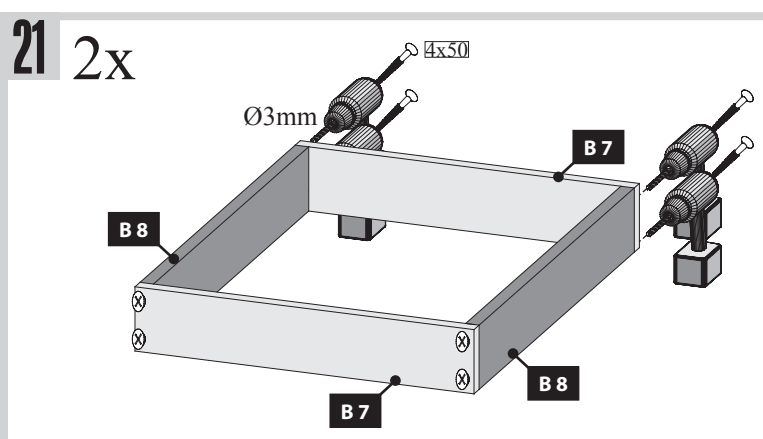
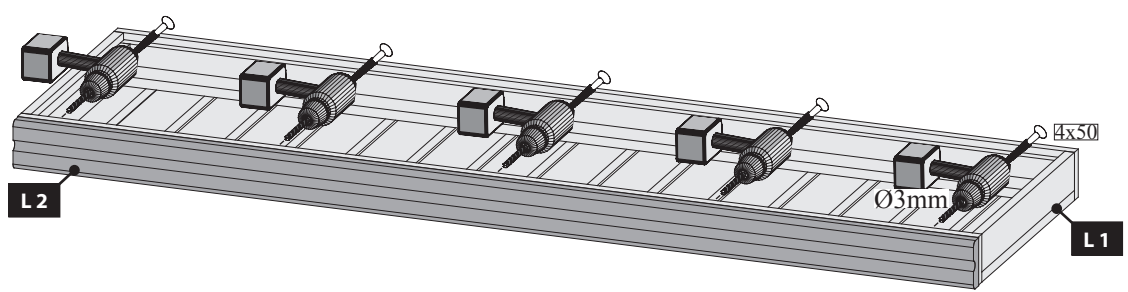
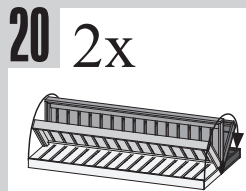

Einbau Glastür

Installation of glass door

Montaje de la puerta de cristal

Montage porte en verre

Montage van de glazen deur

Installazione portello di vetro

!!! 04 — 08 !!!

 Einbau Glastür

 Installation of glass door

 Montaje de la puerta de cristal

 Montage porte en verre

 Montage van de glazen deur

 Installazione portello di vetro

01

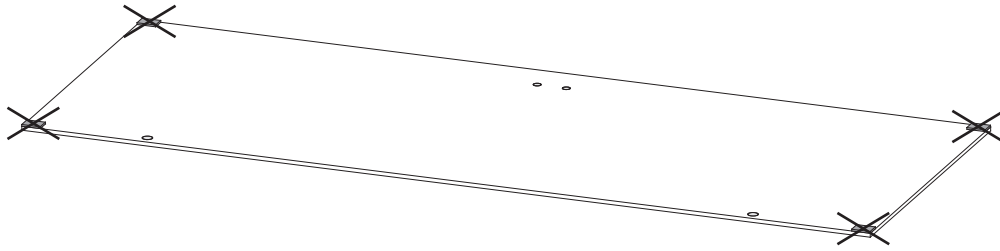

02

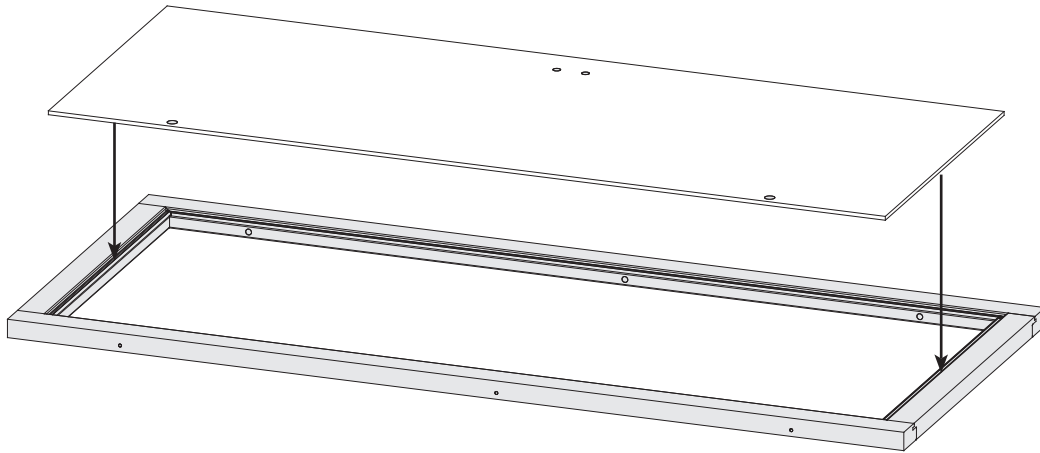



03

 Das Saunätürglas im Türrahmen ausrichten!

 Bien aligner le verre à vitre!

 To start building up the door you need to center the glass in the wooden frame!

 Plaats het glas van de sauna deur in het midden van het kozijn!

 ¡Centrar la puerta de cristal dentro del marco!

 Allineare il vetro dello sportello sauna al telaio della porta!

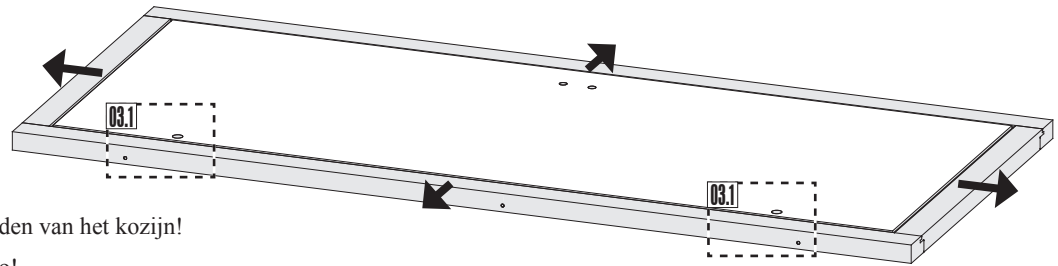

03.1-1

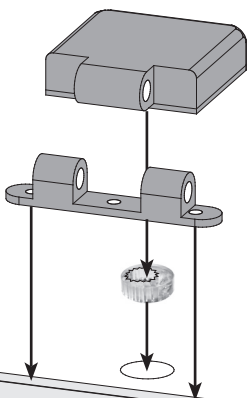

03.1-2

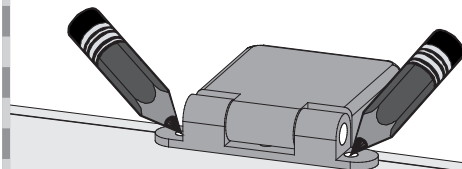

03.1-3

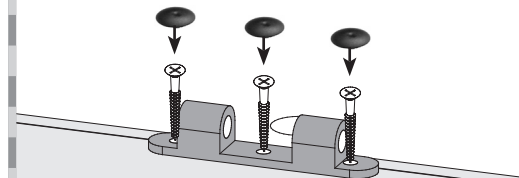

 Einbau Glastür

 Installation of glass door

 Montaje de la puerta de cristal

 Montage porte en verre

 Montage van de glazen deur

 Installazione portello di vetro

04

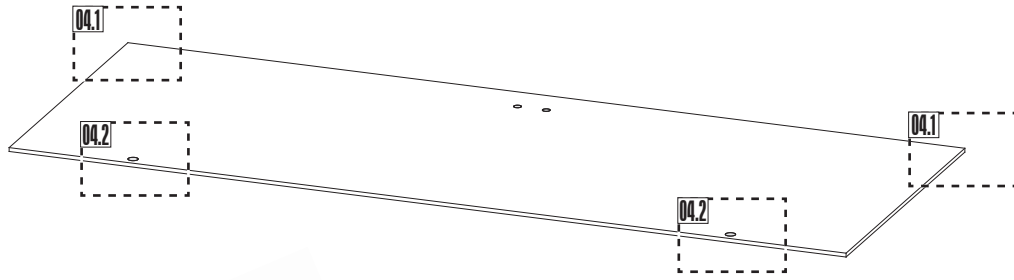

04.1-1

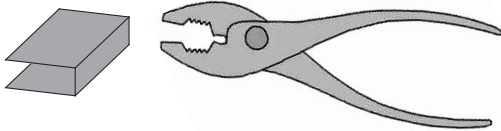

04.1-2

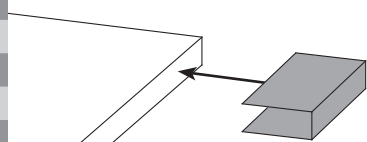

04.1-3

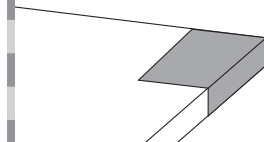

04.2-1

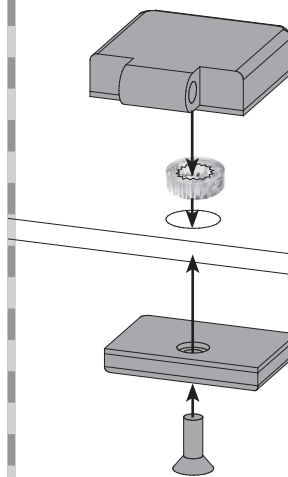

04.2-2

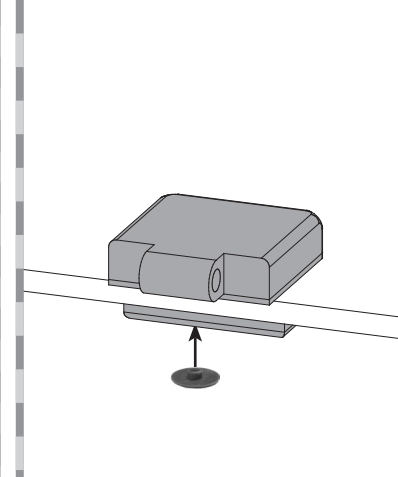

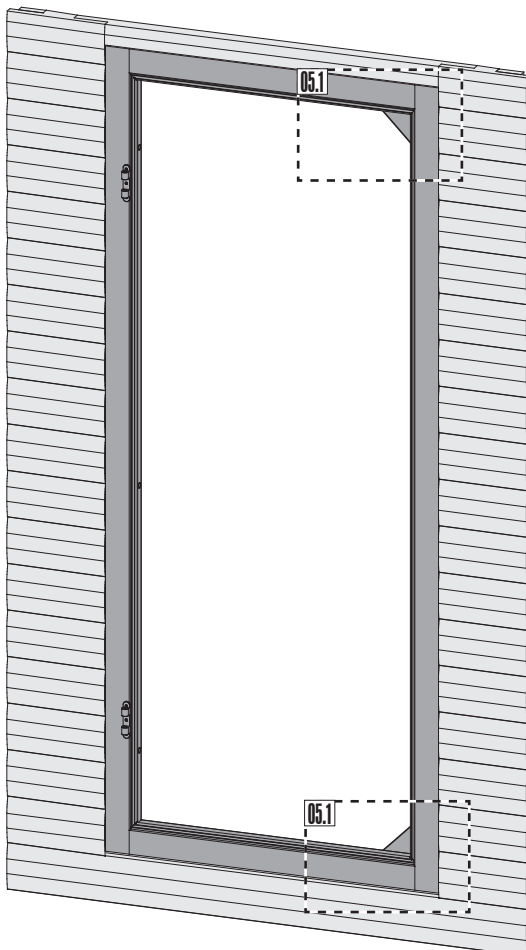

05





 Achtung: Alle Verstell-Excenter müssen in der Glasscheibe die gleiche Grundstellung haben!

 Attention: Tous les excentres de positionnement doivent avoir la même position de base dans la vitre!

 Attention: All adjustable eccentrics must have the same basic adjustment in the glass pane!

 Attentie: alle excentrische verstelelementen moeten in dezelfde stand in de glasplaat worden geplaatst!

 Atención: Todos los excéntricos regulables tienen que tener la misma posición base en la hoja de cristal.

 Attenzione: Tutti gli eccentrici di regolazione devono avere la stessa posizione base nella lastra di vetro!



05.1-1



05.1-2



 Einbau Glastür

 Installation of glass door

 Montaje de la puerta de cristal

 Montage porte en verre

 Montage van de glazen deur

 Installazione portello di vetro

06

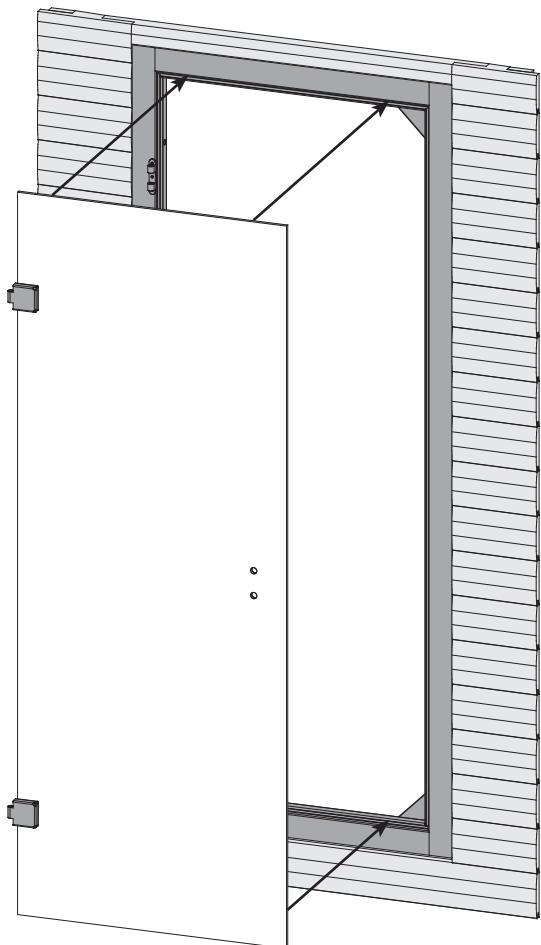

07

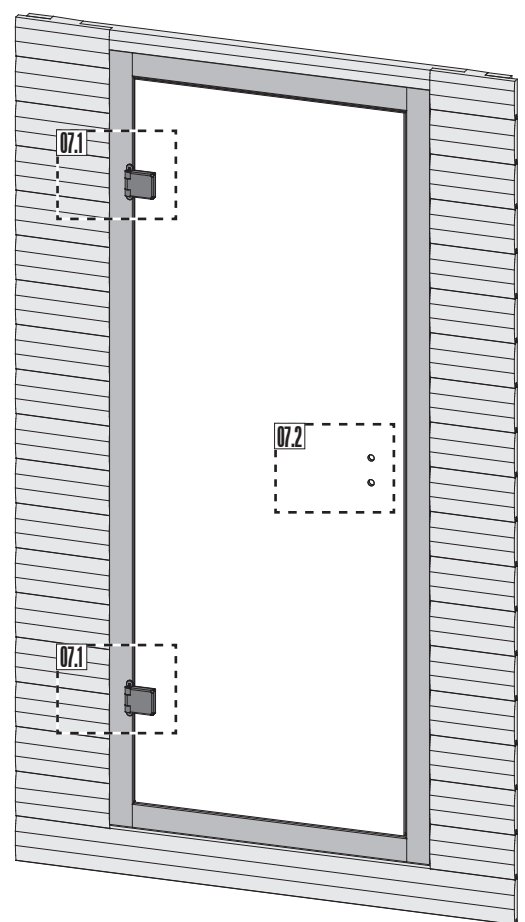

07.1

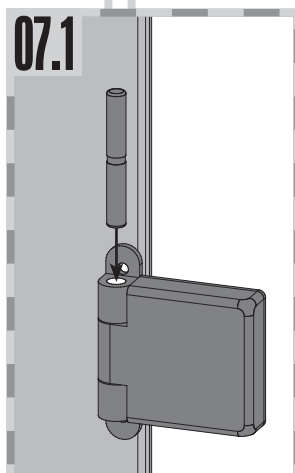

07.2-1

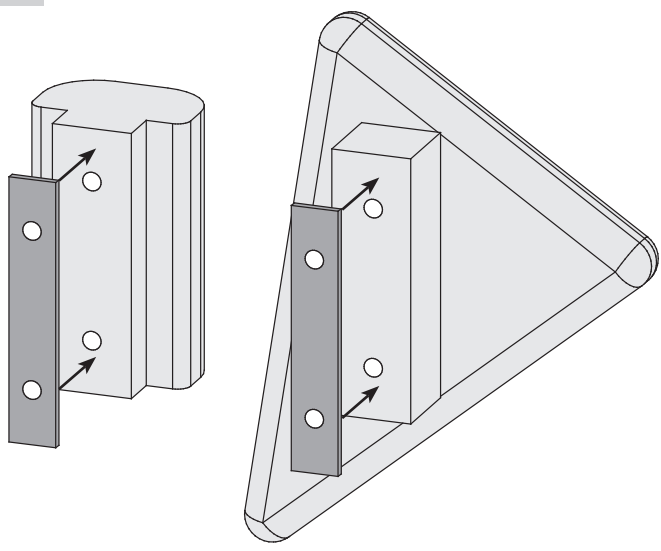

07.2-2

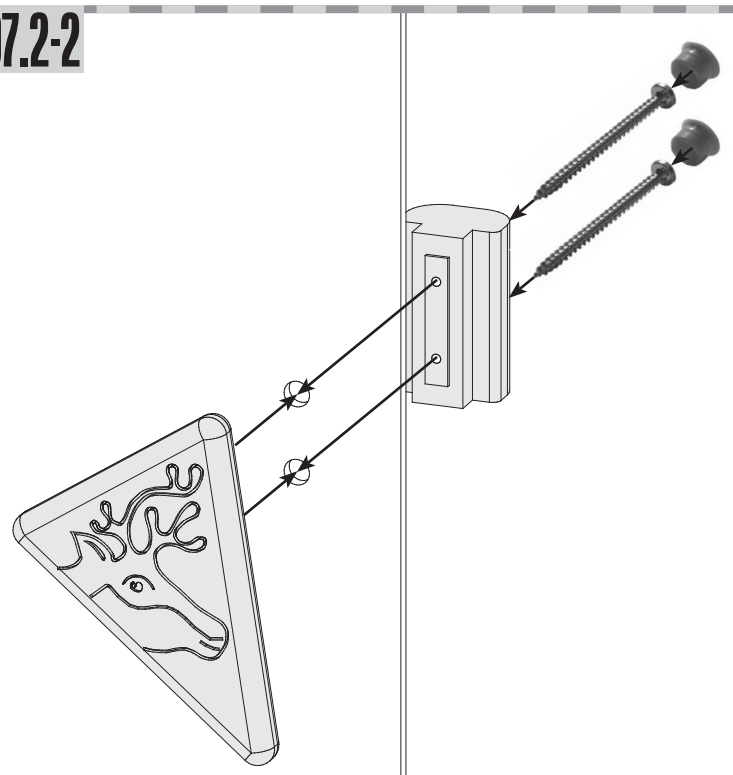

 **Seitenverstellung + Höhenverstellung**

Achtung: Alle Verstell-Excenter müssen in der Glasscheibe die gleiche Grundstellung haben!

 **Positionnement latéral + positionnement hauteur**

Attention: Tous les excentres de positionnement doivent avoir la même position de base dans la vitre!

 **Lateral adjustment + height adjustment**

Attention: All adjustable eccentrics must have the same basic adjustment in the glass panel!

 **Zijverstelling + hoogteverstelling**

Attentie: alle excentrische verstelelementen moeten in dezelfde stand in de glasplaat worden geplaatst!

 **Regulación lateral + regulación de la altura**

Atención: Todos los excéntricos regulables tienen que tener la misma posición base en la hoja de cristal.

 **Regolazione laterale + regolazione dell'altezza**

Attenzione: Tutti gli eccentrici di regolazione devono avere la stessa posizione base nella lastra di vetro!

