

Gewächshaus

Montageanleitung

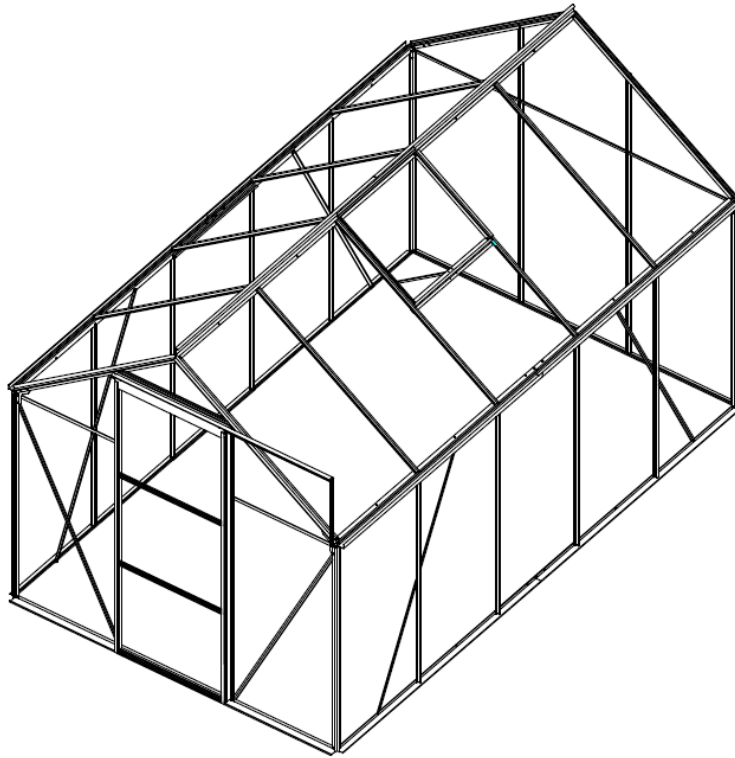

1900mm(L)x3100mm(W)x1950mm(H)

WICHTIG

Lesen Sie diese Anleitung vor dem Aufbau bitte vollständig durch, um Montagefehler oder Beschädigungen zu vermeiden.

Prüfen Sie bitte anhand der Packliste, ob das Gerätehaus vollständig bei Ihnen angekommen ist.

Befolgen Sie die beschriebene Reihenfolge der Anleitung aus.

Ziehen Sie die Stufen im Gewächshaus erst fest, wenn Sie die

Polykarbonatplatten fertig montiert haben.

Bewahren Sie die Anweisungen an einem sicheren Ort auf.

SICHERHEITSHINWEISE

Wir empfehlen dringend die Verwendung von Arbeitshandschuhen.

Vermeiden Sie, das Gewächshaus in windigem oder nassem Zustand zu montieren.

Berücksichtigen Sie mit Aluminiumprofilen nicht keine Freileitungen zu berühren.

Tragen Sie immer Schuhe und Schutzbrillen, wenn Sie mit extrudiertem Aluminium arbeiten.

Entsorgen Sie alle Plastiktüten sicher- halten Sie sie außerhalb der Reichweite von Kindern.

Das Gewächshaus muss auf einer flachen, ebenen Oberfläche positioniert und befestigt werden.

Verschieben und Lehnen Sie sich nicht während der Montage an das Gewächshaus.

Unterlassen Sie die Montage des Gewächshauses, wenn Sie müde sind, Drogen oder Alkohol eingenommen haben oder wenn Sie zu Schwindelanfällen neigen.

Wenn sie eine Trittleiter oder Elektrowerkzeuge verwenden, stellen Sie sicher, dass Sie die Sicherheitsempfehlungen des Herstellers befolgen.

Heiße Gegenstände, wie kürzlich verwendete Grills, Lötlampen usw. sollten nicht im Gewächshaus gelagert werden.

Stellen Sie sicher, dass keine verdeckten Rohre oder Kabel im Boden sind, bevor Sie die Dübel einsetzen.

Bewahren Sie alle kleinen Teile (Schrauben usw.) in einer Schüssel auf, damit sie nicht verloren gehen.

ALLGEMEINE HINWEISE

Es handelt sich um eine mehrteilige Baugruppe, daher wird die Montage mindestens 300 Minuten in Anspruch nehmen.

Wählen Sie eine sonnige, ebene Position und vermeiden Sie überhängende Bäume.

Wenn Sie ihr Gewächshaus direkt an einem festen Betonfundament befestigen, verwenden Sie die Löcher für die Vorbohrung auf der mitgelieferten Metallbasis.

Die Bauteile sollten in unmittelbarer Nähe überprüft und ausgelegt werden.

Beachten Sie, dass die Tür an der rechten Seite angebracht wird und sich somit nach rechts öffnet.

Halten Sie das Dach frei von Schnee und Laub.

PFLEGE UND WARTUNG

Wenn Ihr Gewächshaus gereinigt werden muss, verwenden Sie ein mildes Reinigungsmittel und verdünnen Sie es in Wasser.





Verwenden sie **KEINE** Aceton-, Schleifmittel- oder sonstige Reinigungsmittel zur Reinigung der Klarsichtscheiben.

WERKZEUG UND AUSRÜSTUNG

Silikondichtungsmittel & Applikator, Bradawl Phillips Schraubenzieher, Leiter, Maßband, großer Hammer, Schere, Arbeitshandschuhe, Bohrmaschine, Wasserwaage, Schmiermittel für Kunststoff und Gummi.







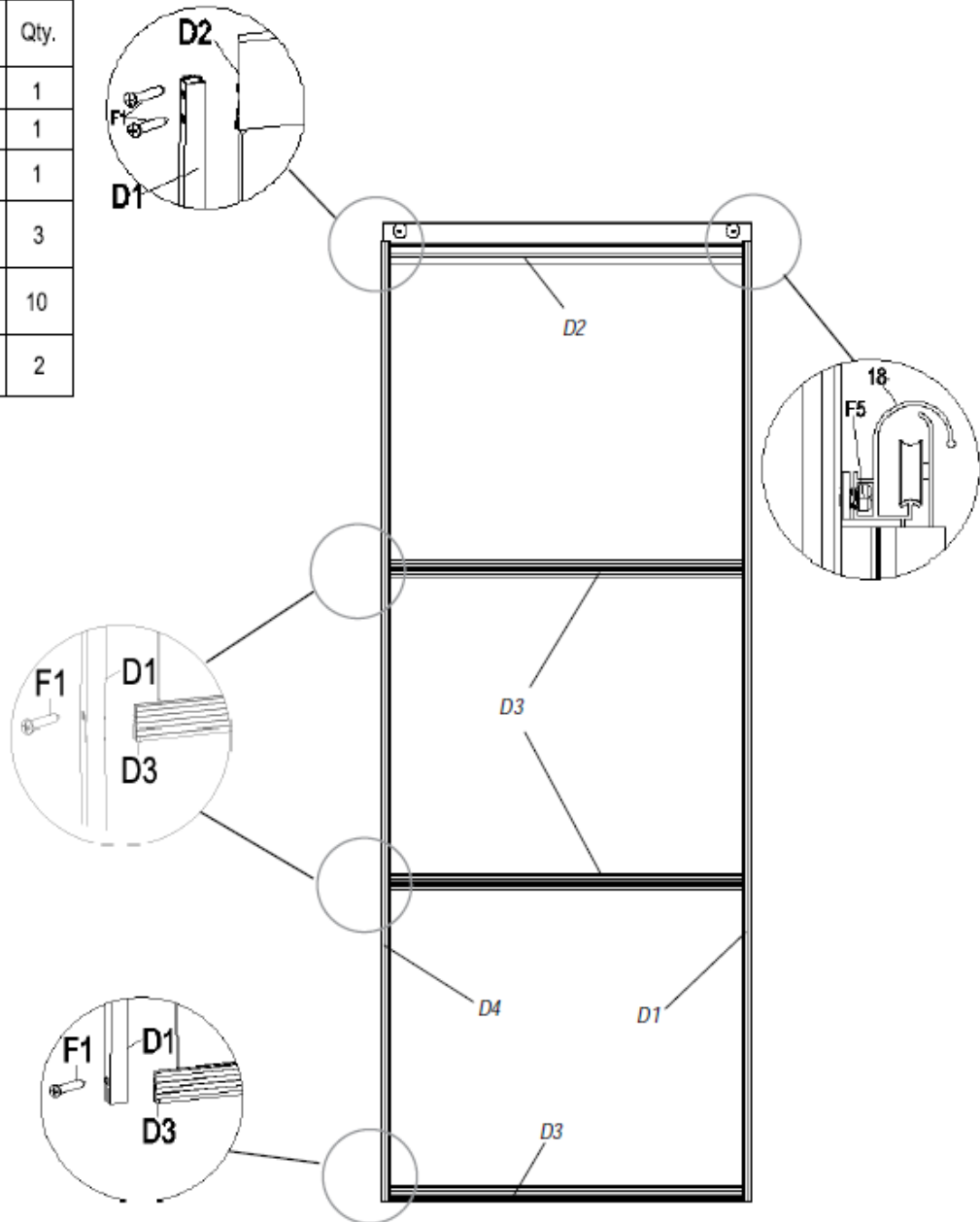

Wenn Hilfe benötigt wird, wenden Sie sich an eine professionelle Beratung im Geschäft.

Tür







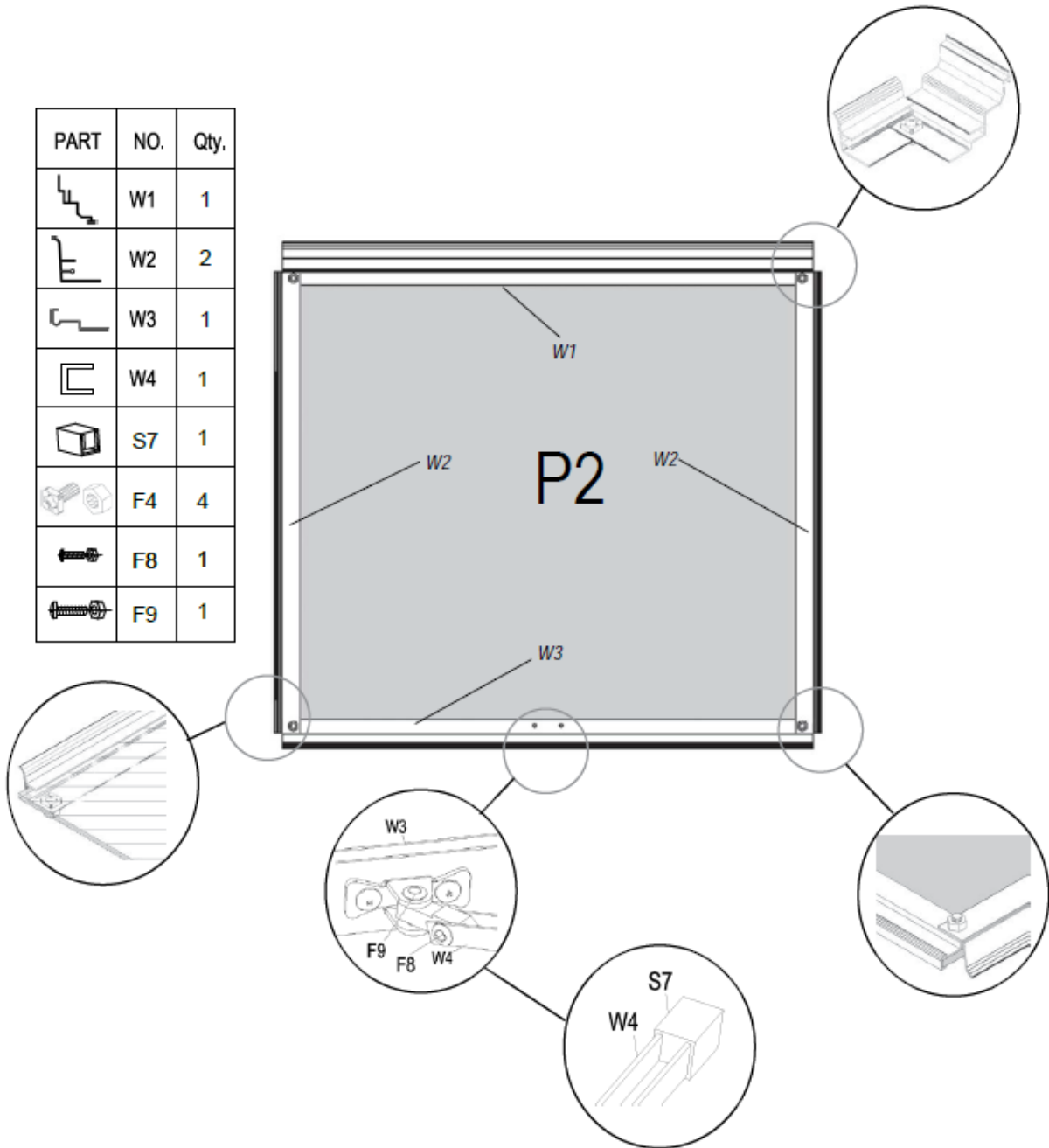

PART	NO.	Qty.
	D1	1
	D4	1
	D2	1
	D3	3
	F1	10
	F5	2



Fenster

PART	NO.	Qty.
	W1	1
	W2	2
	W3	1
	W4	1
	S7	1
	F4	4
	F8	1
	F9	1



PART	NO.	Qty.
	4	2
	4-1	2
	8	2
	8-1	2
	26	4
	17	2
	27	1
	F4	24

Connector For Base->D-4

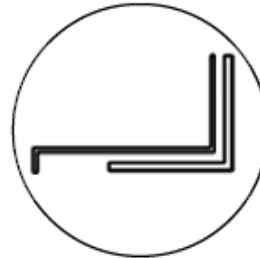
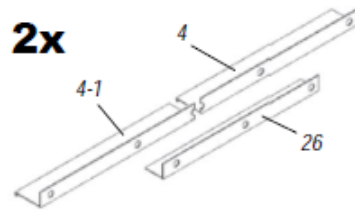



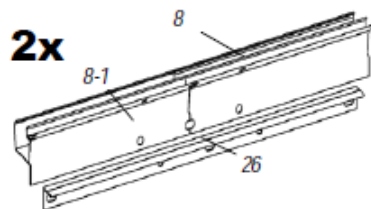



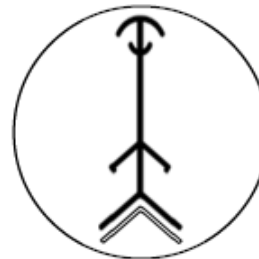
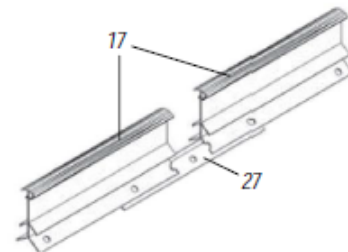

Connector For Eaves->D-8







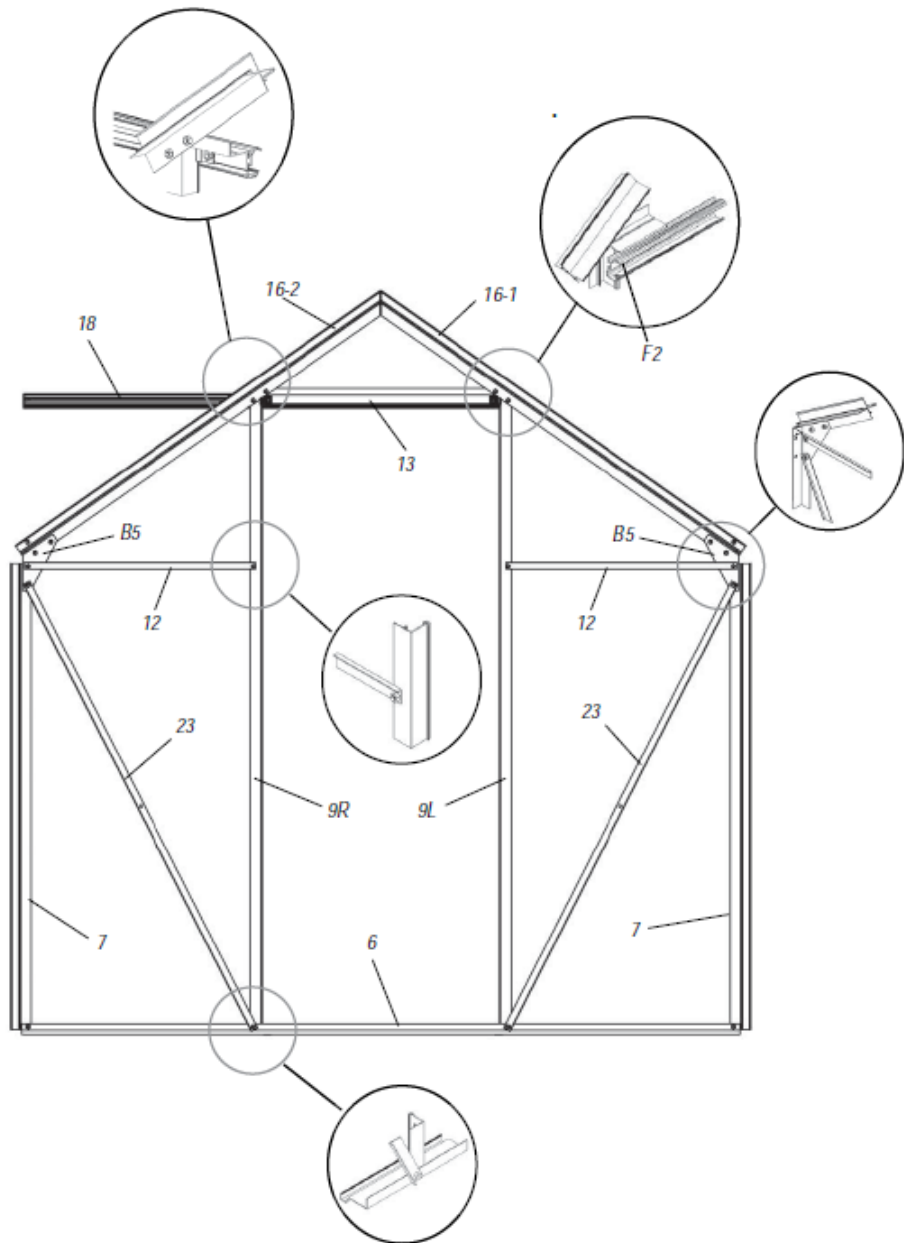

Connector For Roof->D-17







PART	NO.	Qty.
	7	2
	16-1	1
	16-2	1
	6	1
	18	1
	13	1
	9R	1
	9L	1
	12	2
	23	2
	B5	2
	F4	20
	F2	1

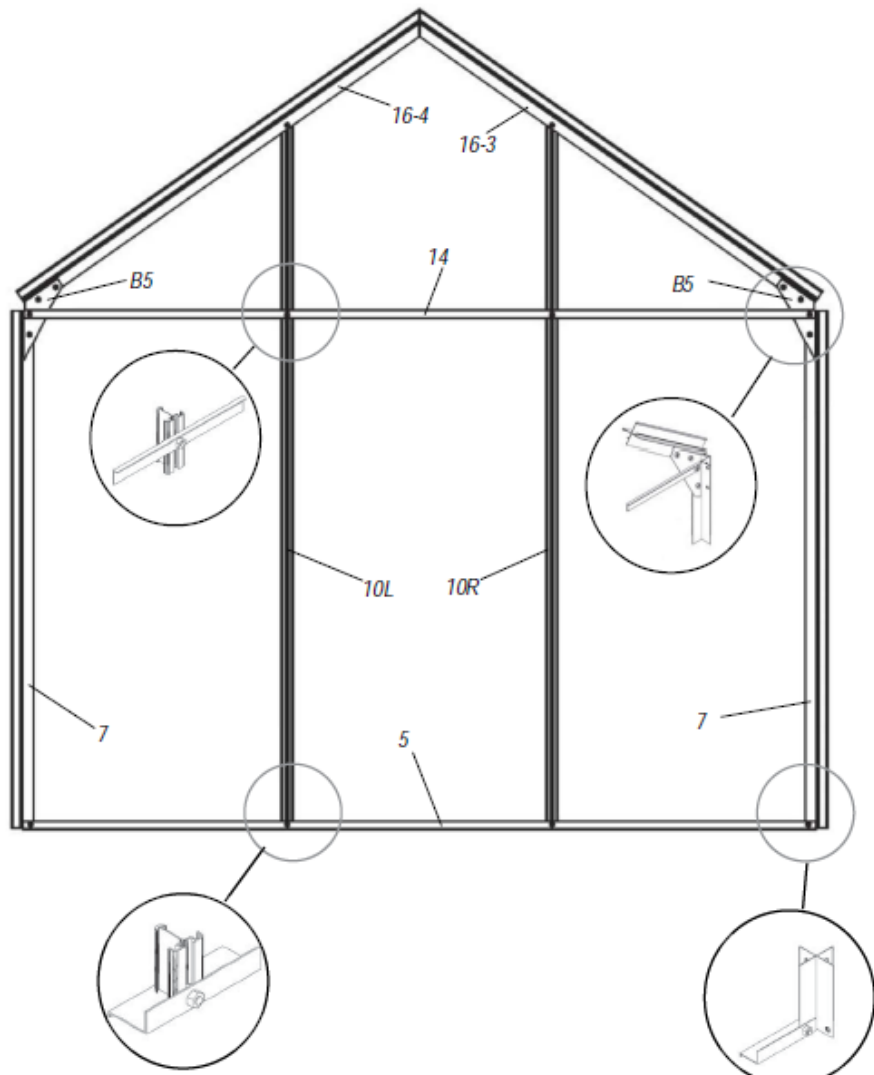







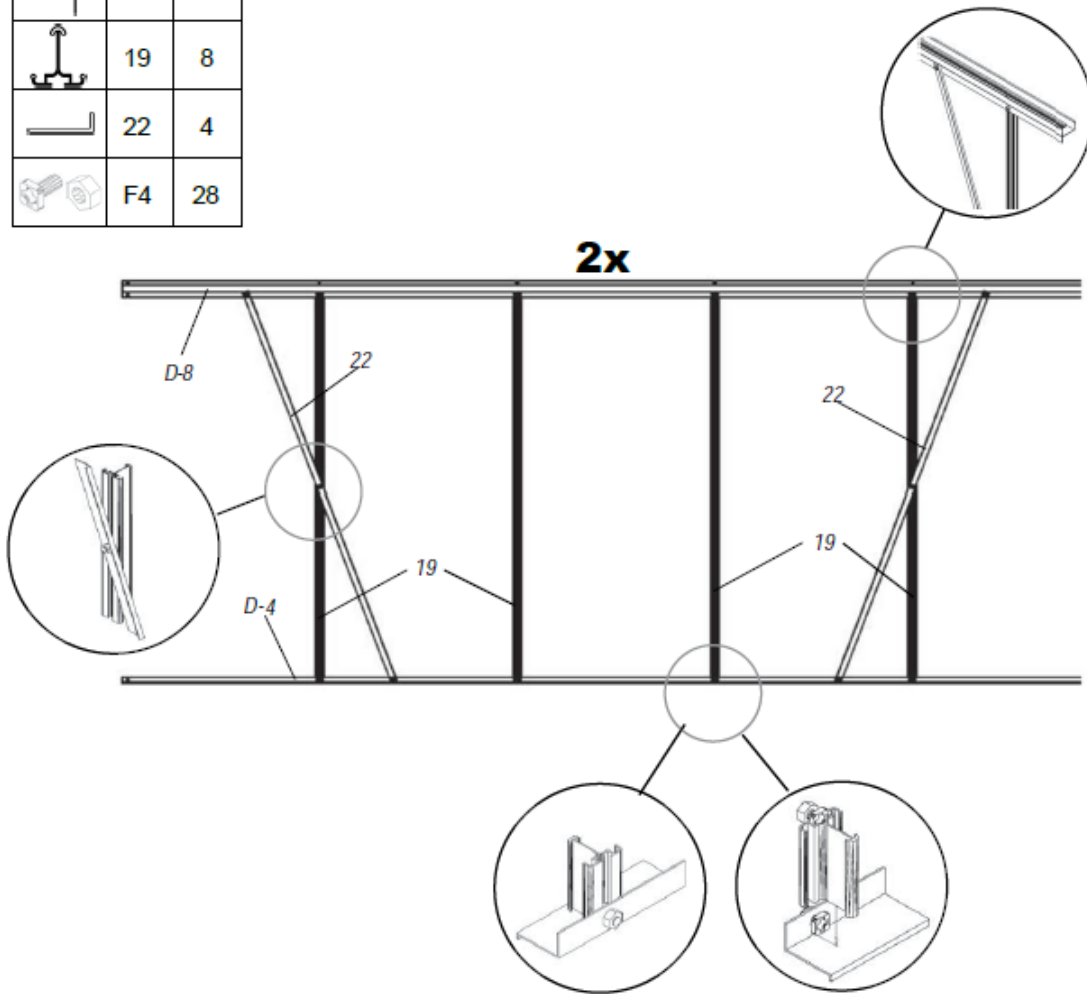

PART	NO.	Qty
	7	2
	16-3	1
	16-4	1
	5	1
	10R	1
	10L	1
	14	1
	B5	2
	F4	16







PART	NO.	Qty.
	D-4	2
	D-8	2
	19	8
	22	4
	F4	28

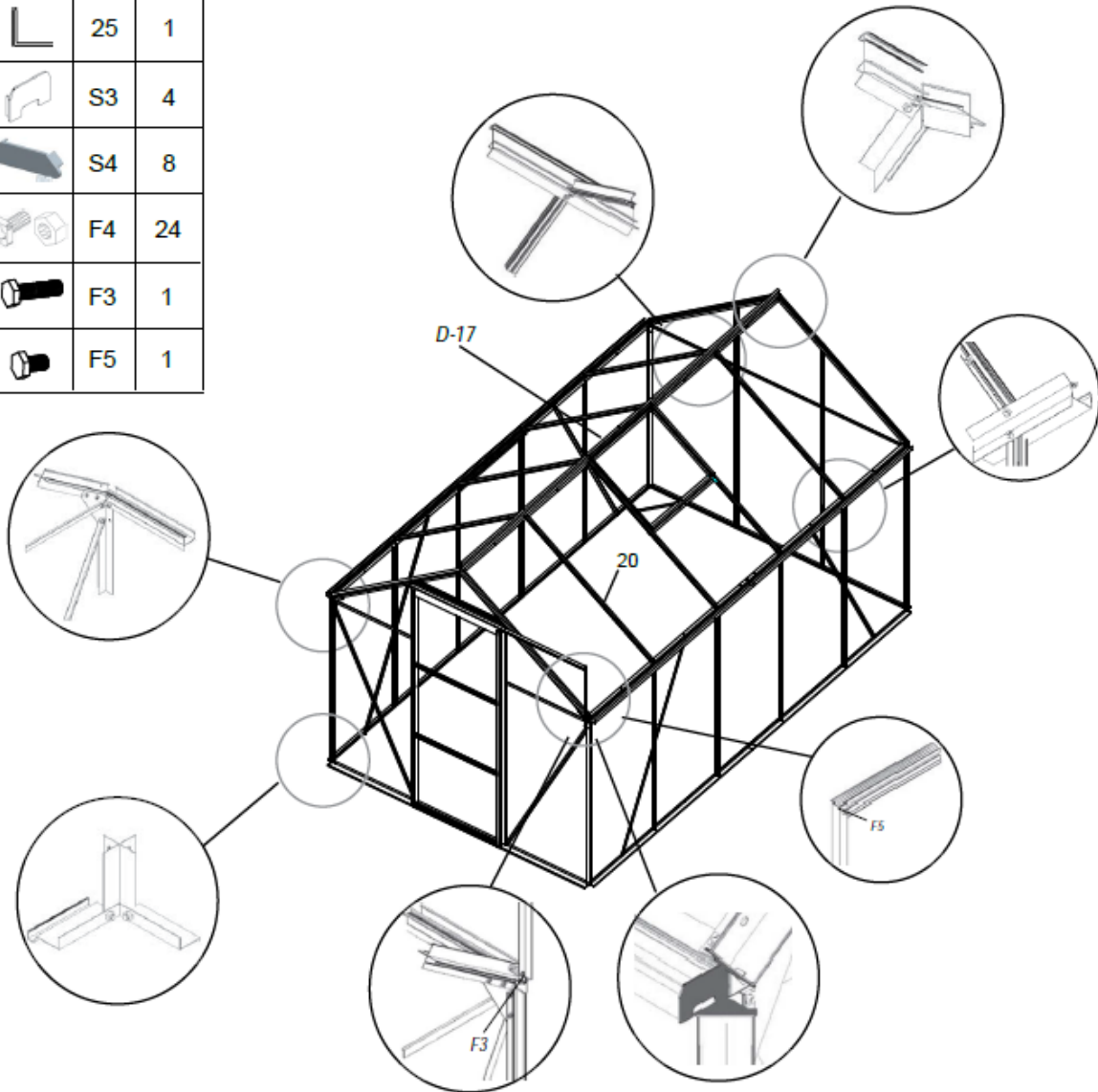





PART	NO.	Qty.
	D-17	1
	20	8
	25	1
	S3	4
	S4	8
	F4	24
	F3	1
	F5	1

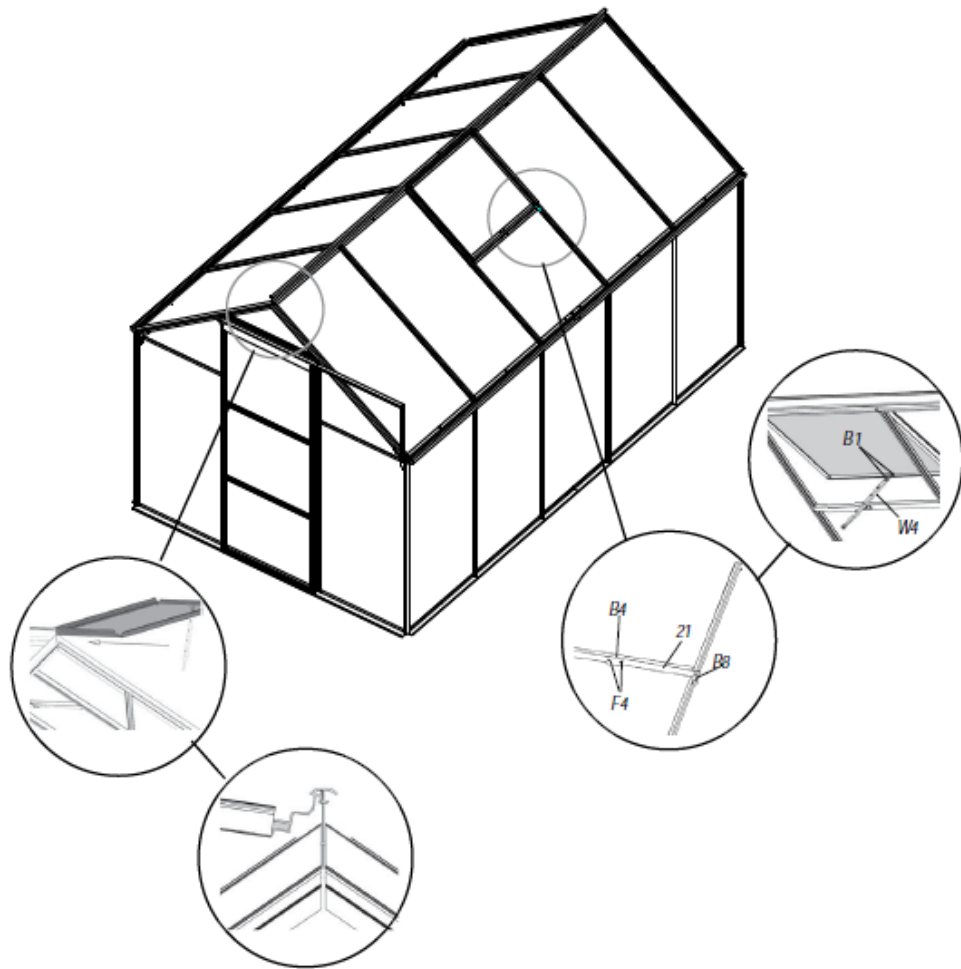

PART	NO.	Qty.
	21	1
	B4	1
	B8	1
	F4	4



PART	NO.	Qty.
	15	5
	B3	140
	B6	1
	S1	30

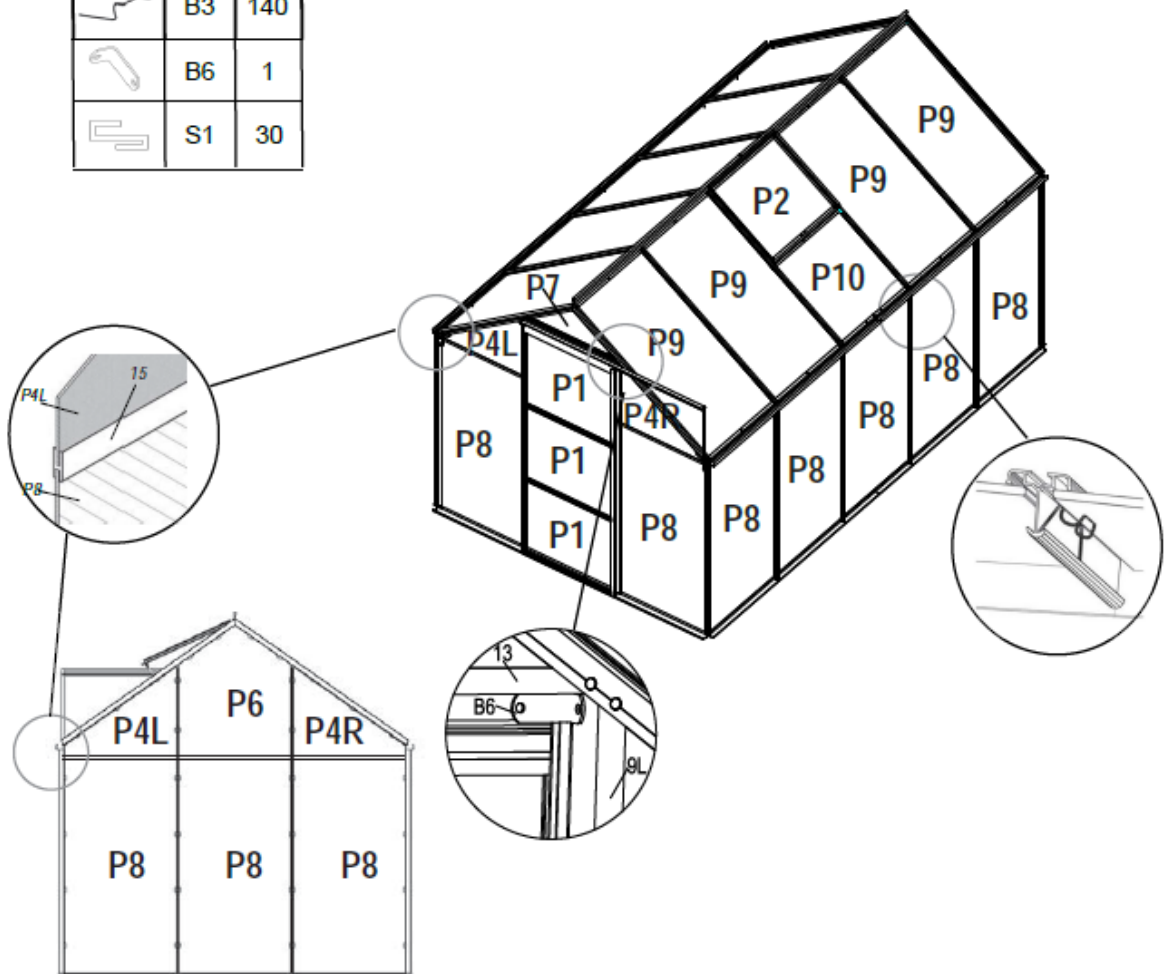

7		4
16-1		1
16-2		1
16-3		1
16-4		1
6		1
5		1
4		2
4-1		2
26		4
8		2
8-1		2
17		2
27		1
19		8
20		8
10R		1
10L		1
9R		1
9L		1
13		1
18		1

25		1
14		1
12		2
22		4
23		2
21		1
15		5
W1		1
W2		2
W3		1
D1		1
D4		1
D2		1
D3		3
B3		140
B4		1
B5		4
B6		1
B8		1

W4		1
S3		4
S4		8
S7		1
F1		10
F2		1
F3		1
F4		120
F5		3
F8		1
F9		1

P8		15
P9		9
P10		1
P4L		2
P4R		2
P6		1
P7		1
P2		1
P1		3