

13968 14122

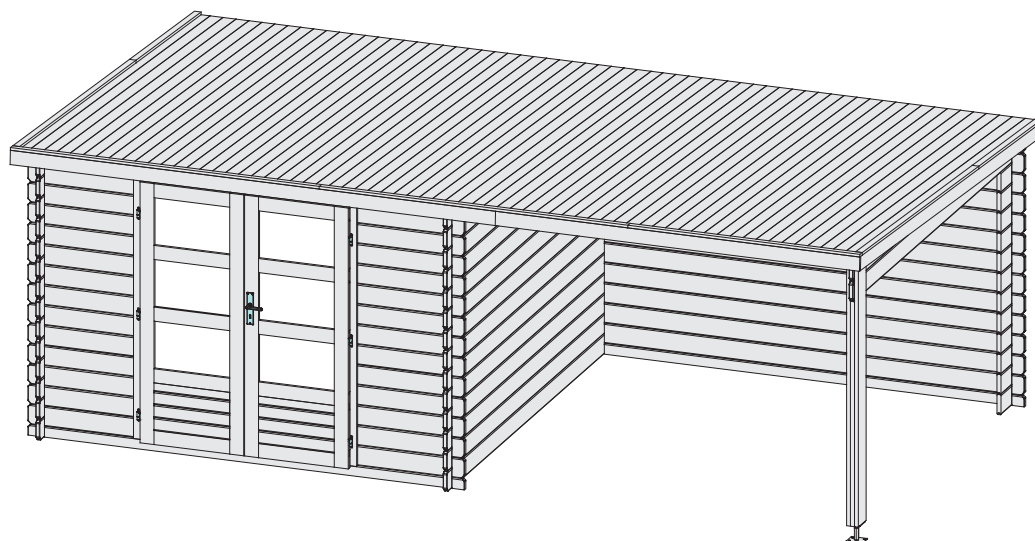

-  **Aufbauanleitung**
-  **Building Instructions**
-  **notice de montage**
-  **montagehandleiding**
-  **Montagevejledning**
-  **Instrucciones de construcción**
-  **Istruzioni per il montaggio**
-  **Montážní návod**



info@karibu.de

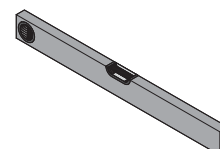
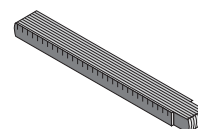
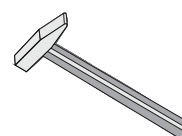
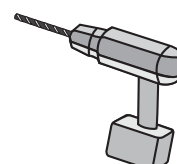
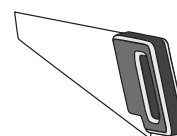



Vergleichen Sie zuerst die Material-liste mit Ihrem Paketinhalt! Bitte haben Sie Verständnis, dass Beanstandungen nur im nicht aufgebauten Zustand bearbeitet werden können!



Vergelijk eerst de lijst van materialen met de inhoud van uw pakket! Reclamaties kunnen alleen in behandeling worden genomen zolang de onderdelen nog niet zijn gemonteerd!



Confrontate questa distinta materiali prima con il contenuto del pacchetto! Vi preghiamo di comprendere che eventuali reclami possono essere accolti solo prima del montaggio!



First compare the list of materials with your package contents! Please understand that complaints can be processed in the non-built status only!



Start med at kontrollere materialelisten med indholdet af den leverede pakke! Vi gør venligst opmærksom på at reklamationer kun kan behandles for materialer som ikke er blevet bearbejdet!



Nejprve přezkontrolujte obsah balení podle materiálového listu! Mějte pochopení pro to, že případnou reklamaci se můžeme zabývat pouze tehdy, když díly nebudou smontované! Za pomoci tohoto seznamu můžete jednotlivé díly přiřadit k montážnímu návodu.



Commencez par comparer la liste du matériel avec le contenu de votre paquet! Sachez que nous traitons uniquement les réclamations concernant le matériel à l'état non monté!



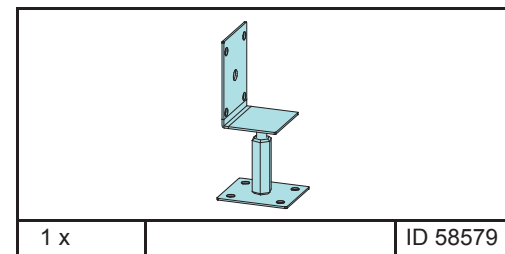
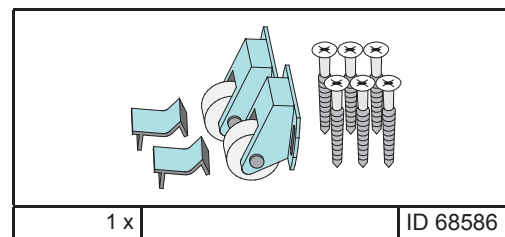
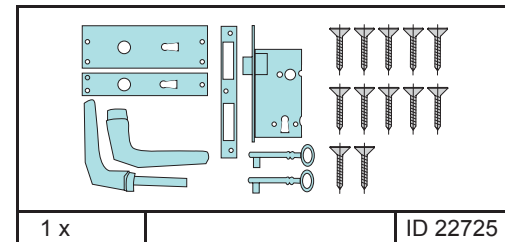
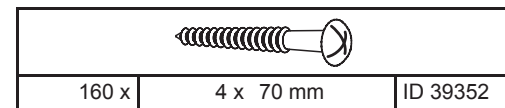
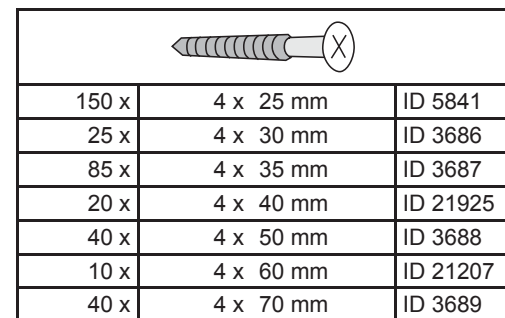
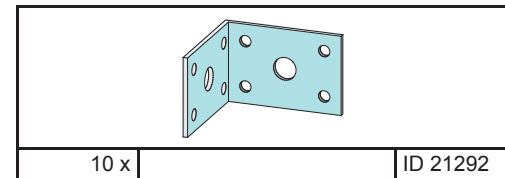
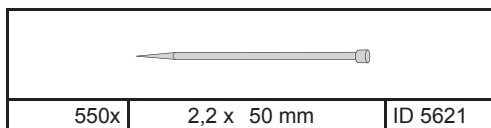
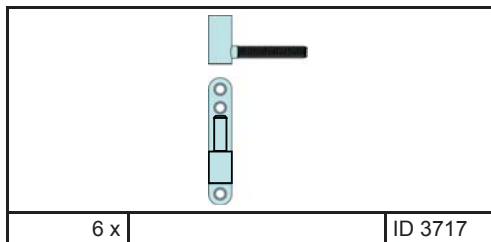
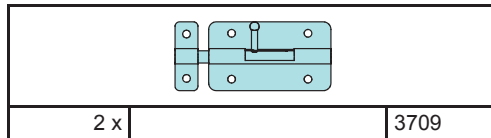
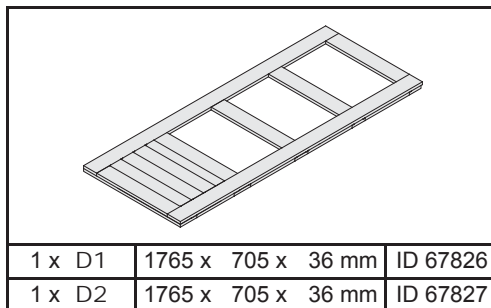
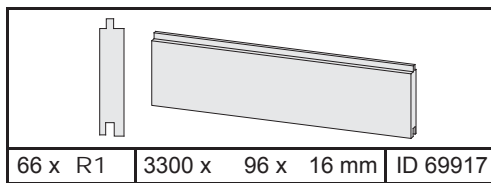
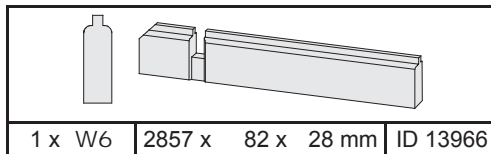
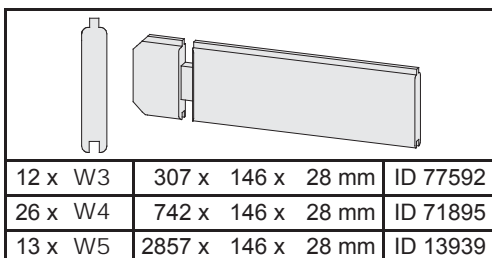
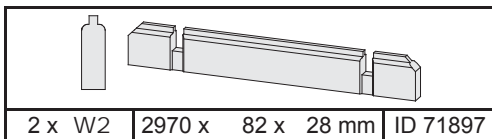
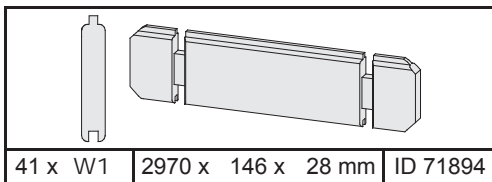
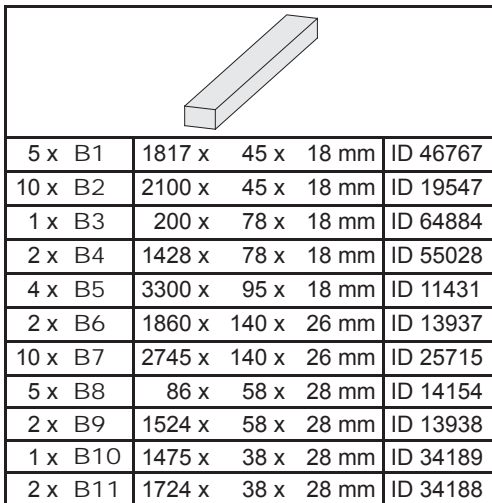
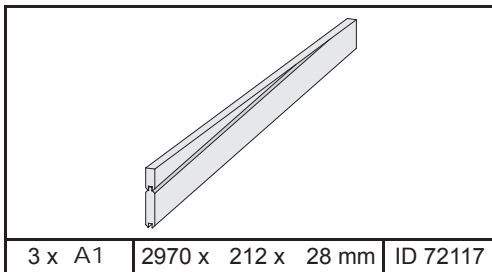
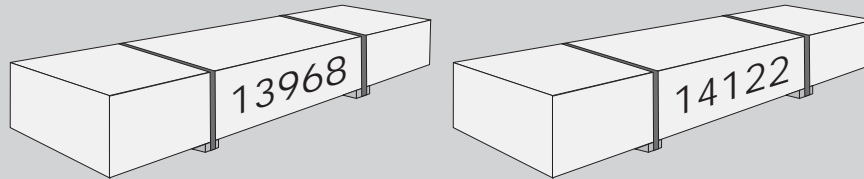

En primer lugar, compare la lista de material con el contenido del paquete. Rogamos entienda que las reclamaciones sólo pueden ser tramitadas antes de montar el objeto!



 Übersicht
 Overview
 enquête

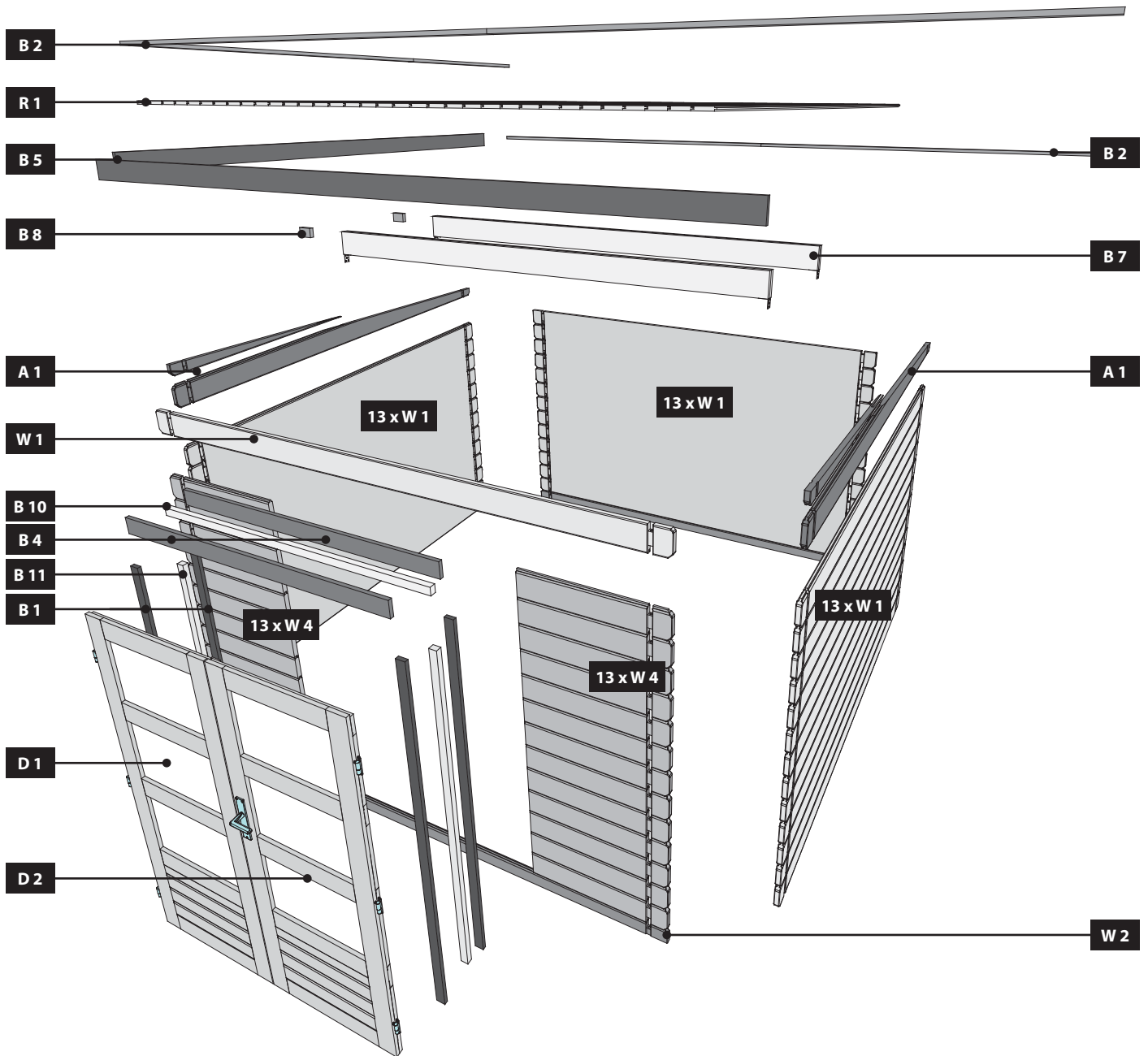

 overzicht
 undersøgelse
 estudio

 sondaggio
 přehled







 Übersicht
 Overview
 enquête

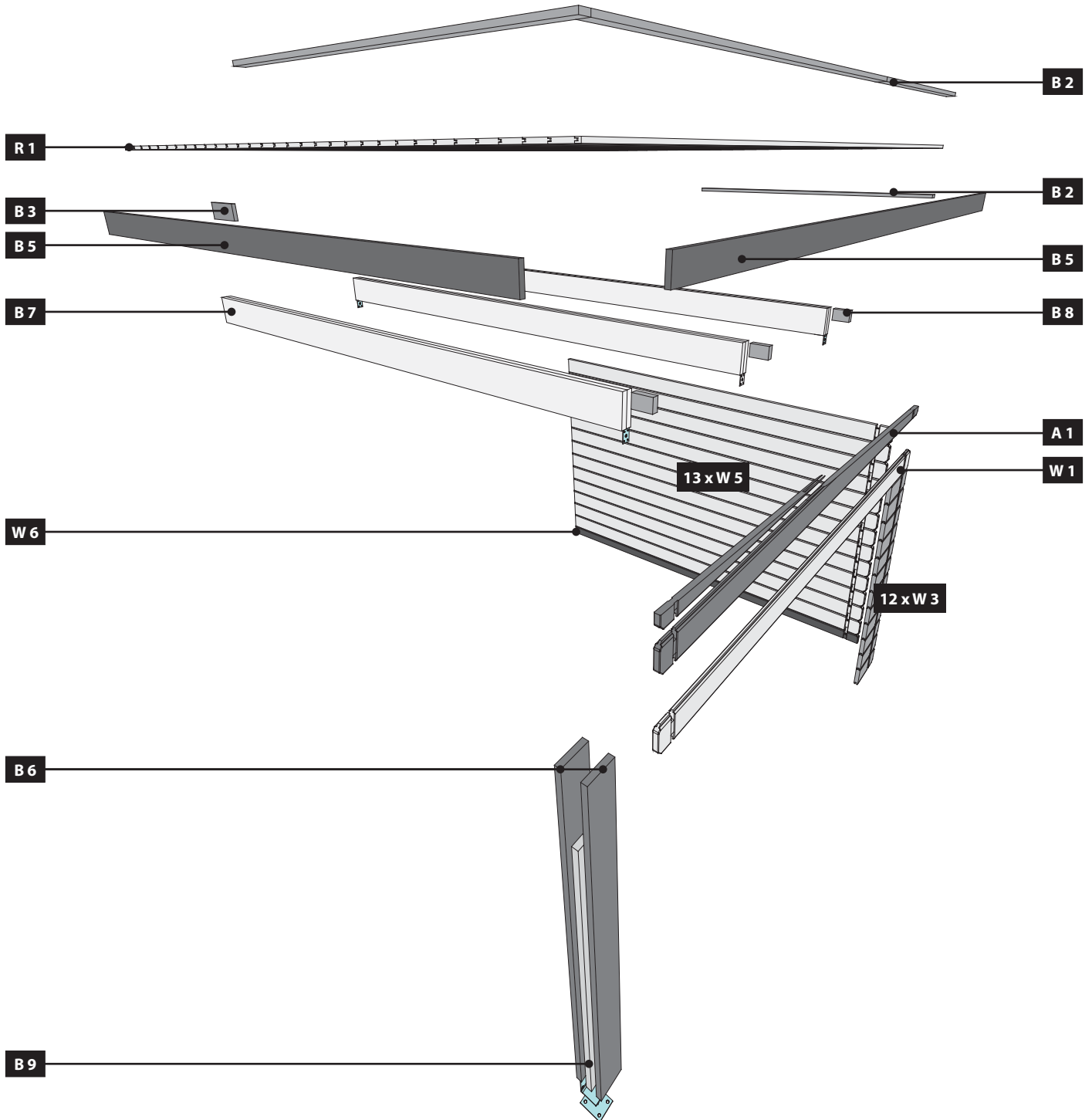



 overzicht
 undersøgelse
 estudio

 sondaggio
 přehled



*

 Nicht im Lieferumfang enthalten
 Not included
 Non comprises dans la livraison
 Niet bijgeleverd

 No forman parte del suministro
 Non incluso
 V ceně není zahrnuto
 Ikke inkluderet

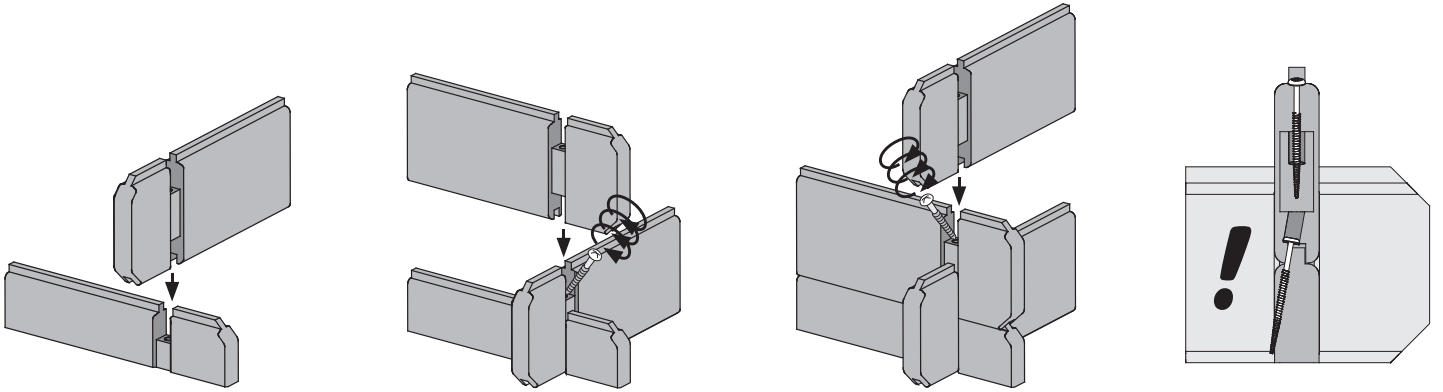

01

Ø3 mm 4x70

8x

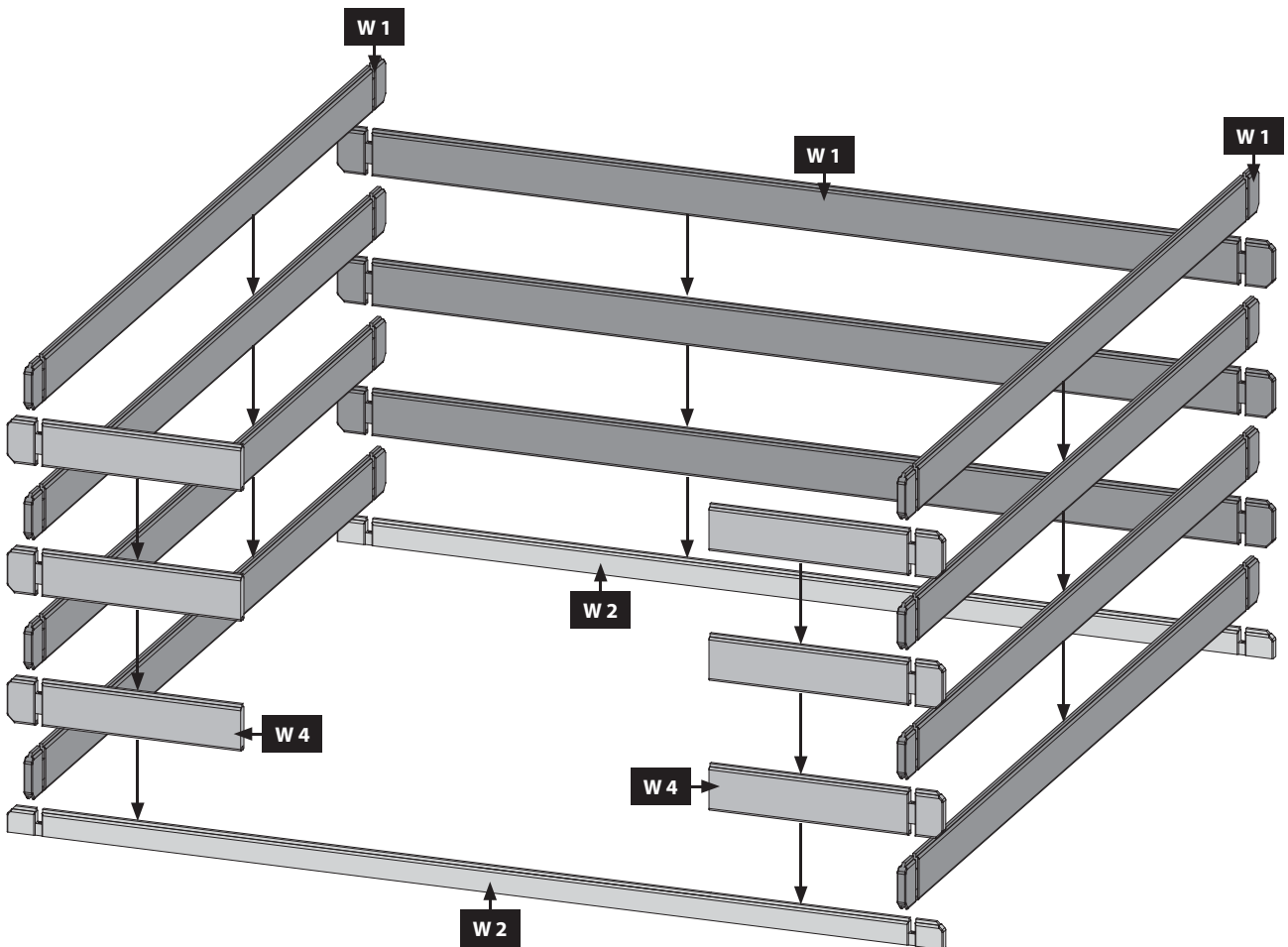

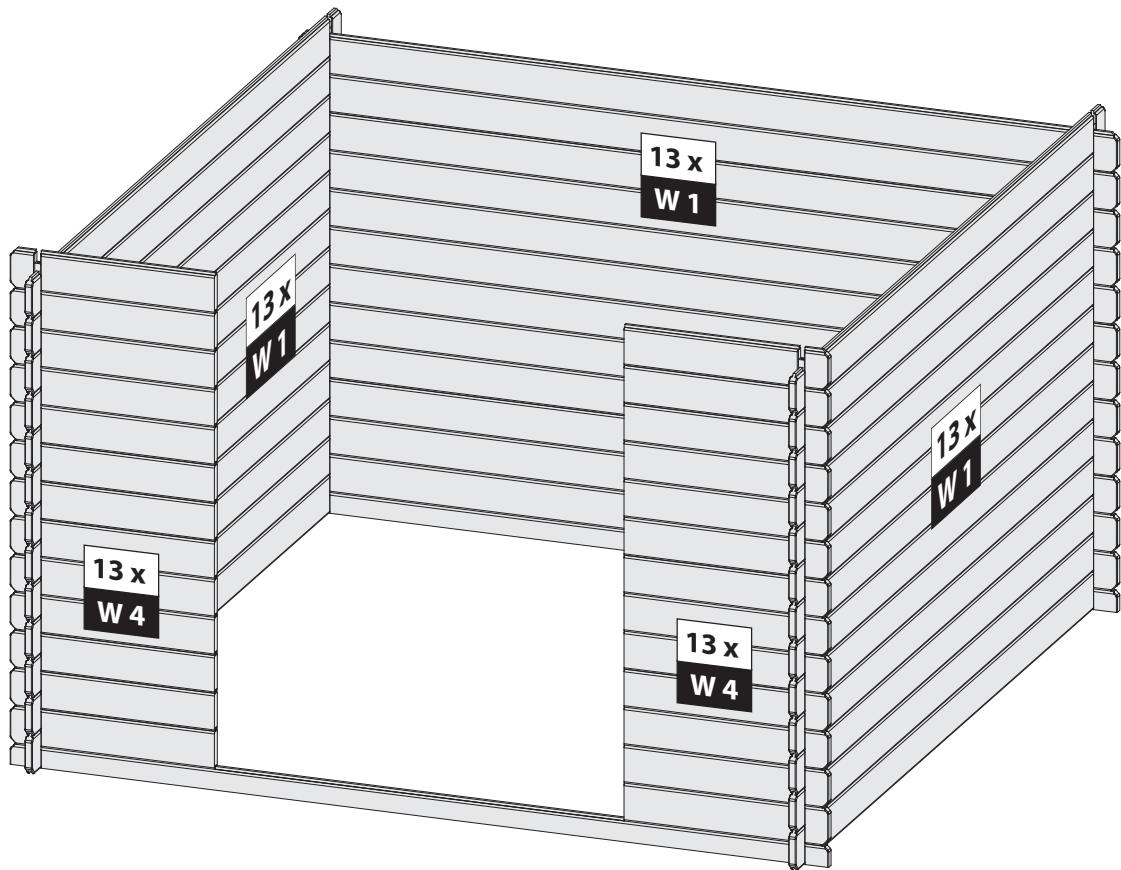

02

Ø3 mm 4x70
10x

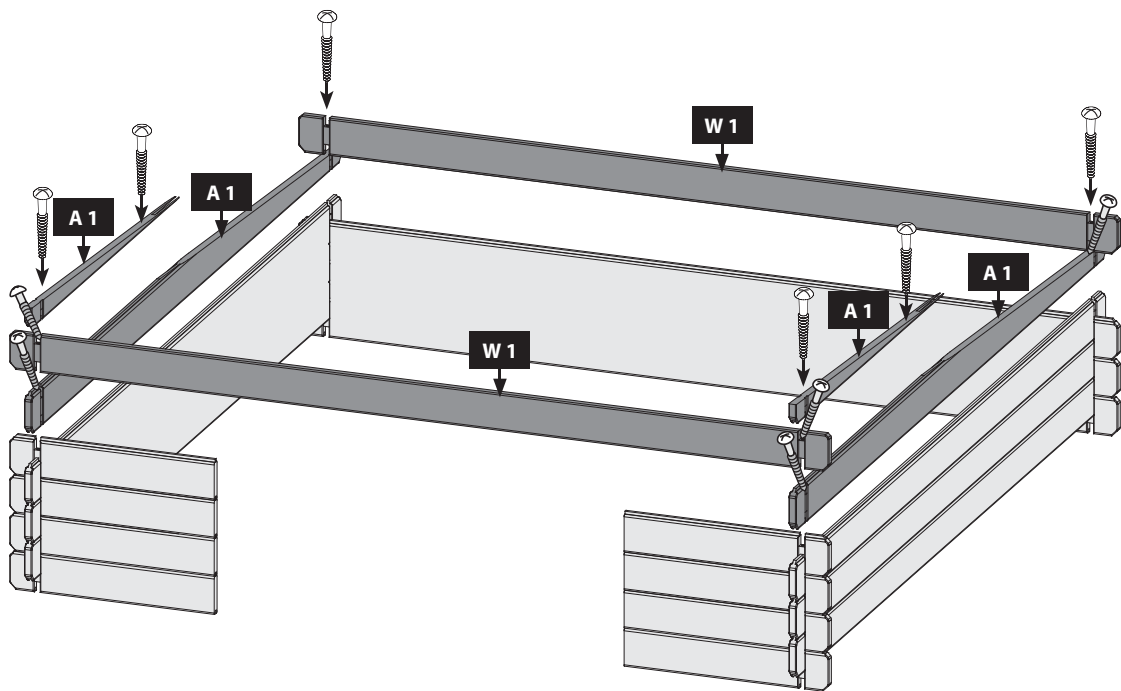
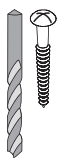

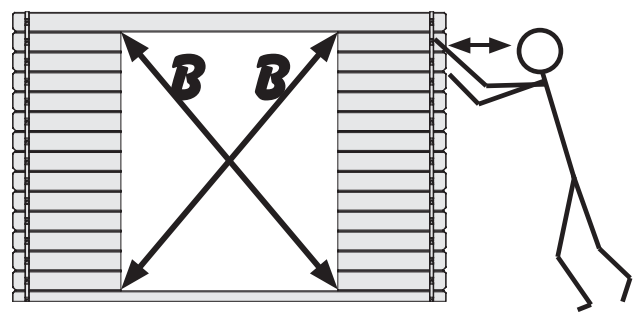
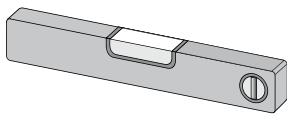
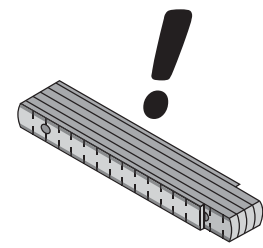
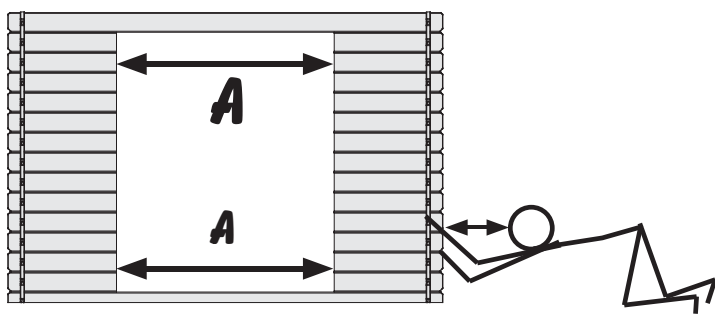
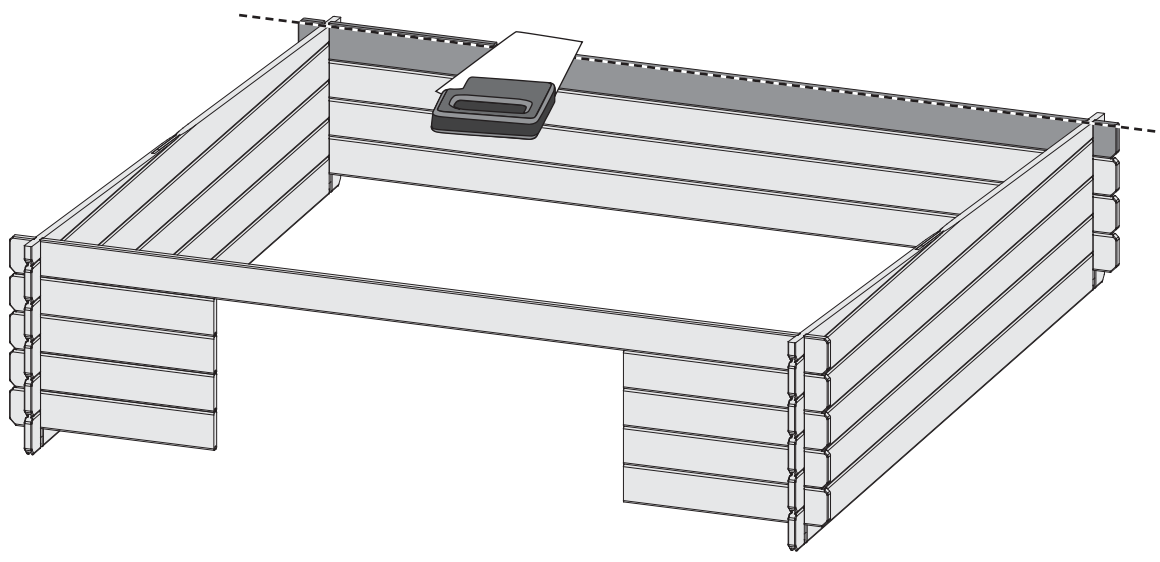

-  Bündig!
-  Flush!
-  Affleurement!
-  Gelijk!
-  I flugt!
-  Aras!
-  Combacia!
-  Stejný!

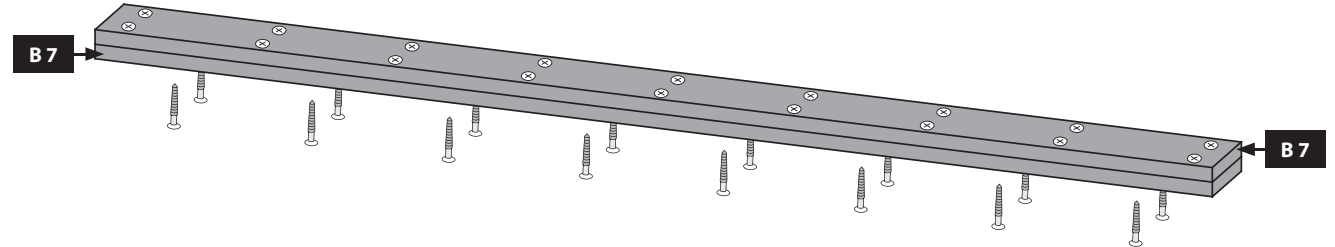

5x

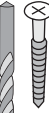

Ø3 mm  4x35
34x 

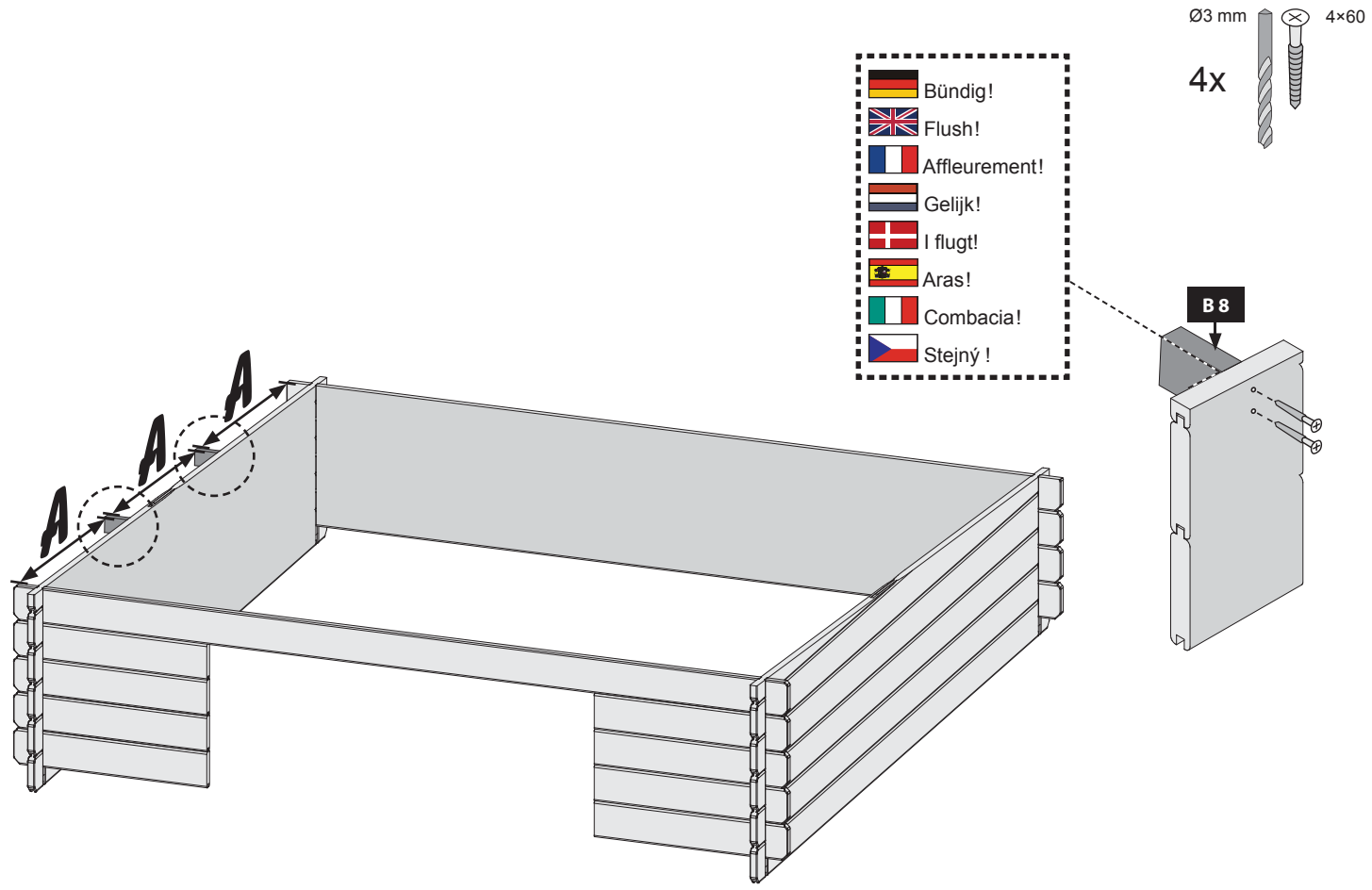

-  Bündig!
-  Flush!
-  Affleurement!
-  Gelijk!
-  I flugt!
-  Aras!
-  Combacia!
-  Stejný!

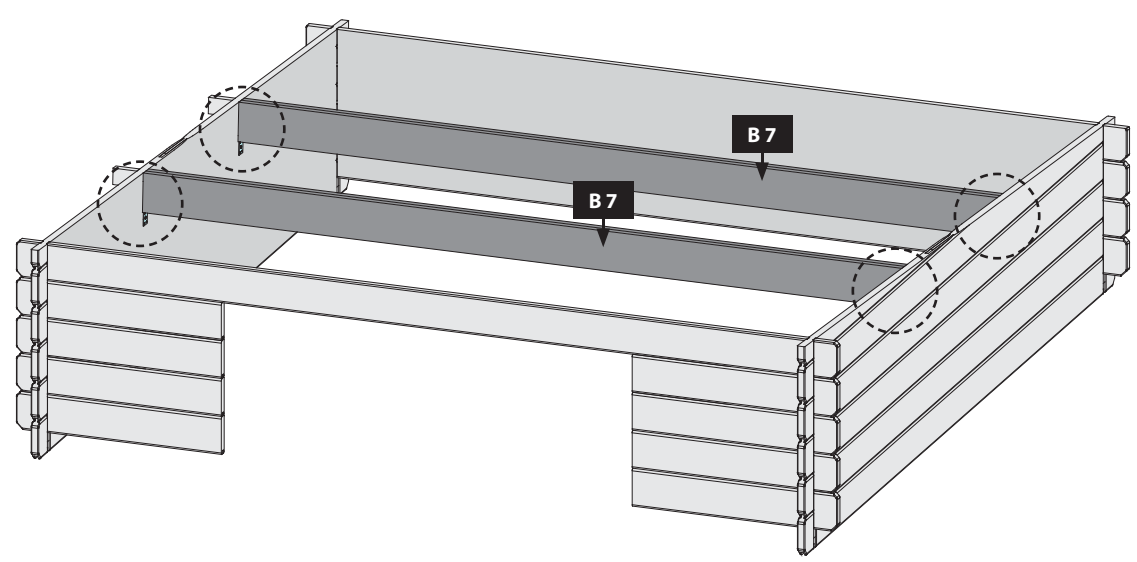
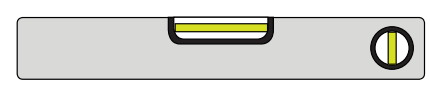
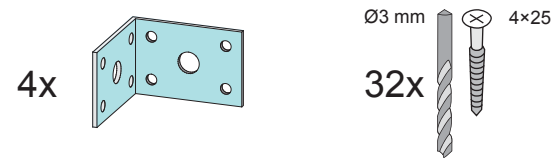
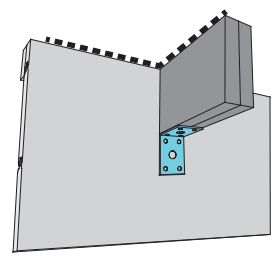

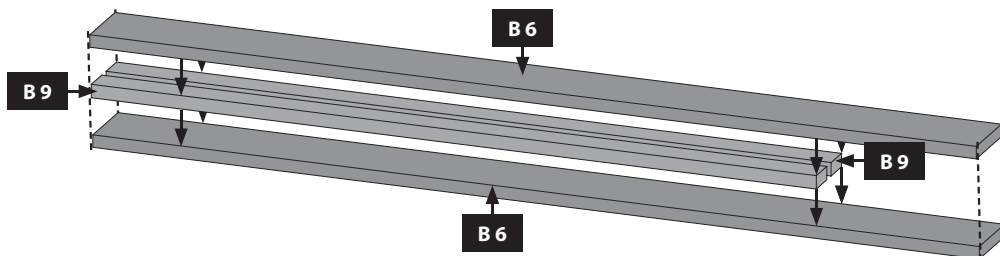

08



-  Bündig!
-  Flush!
-  Affleurement!
-  Gelijk!
-  I flugt!
-  Aras!
-  Combacia!
-  Stejný !

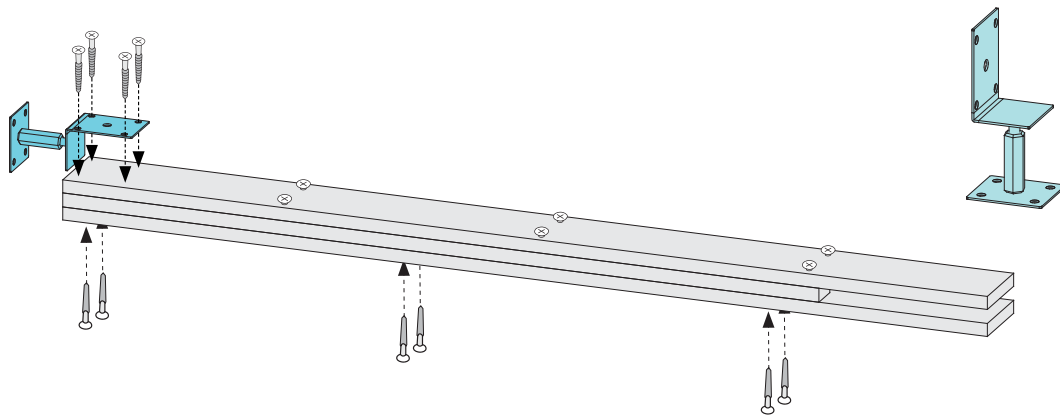

09



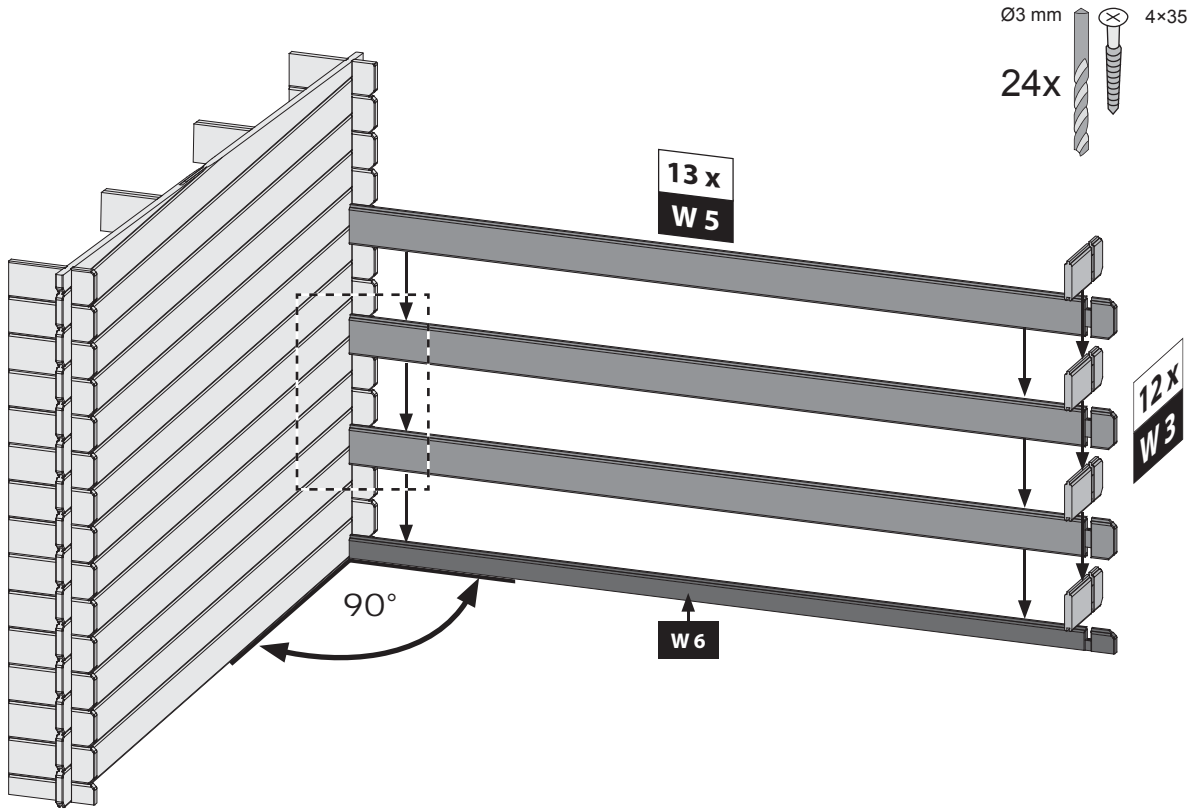

Ø3 mm  4x50
16x 

10



Ø3 mm  4x35
24x 

Ø3 mm  4x70
24x 

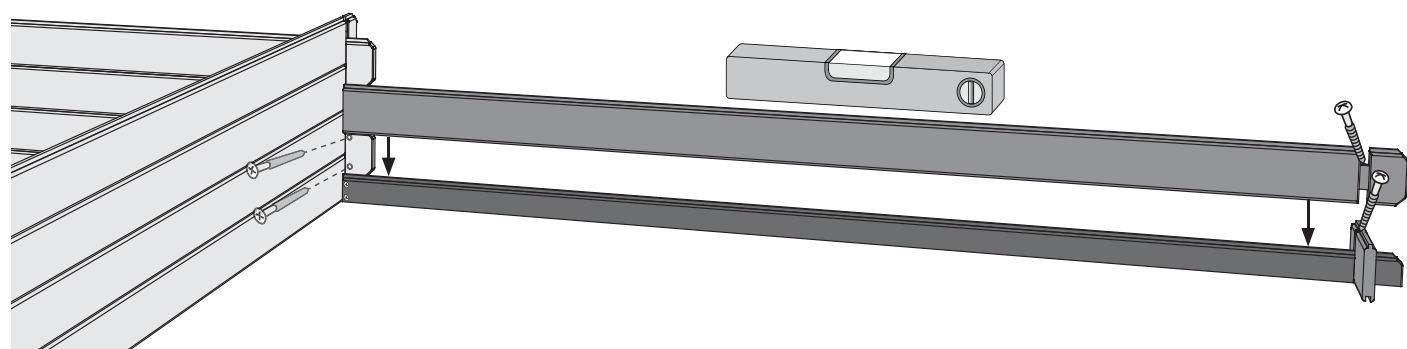

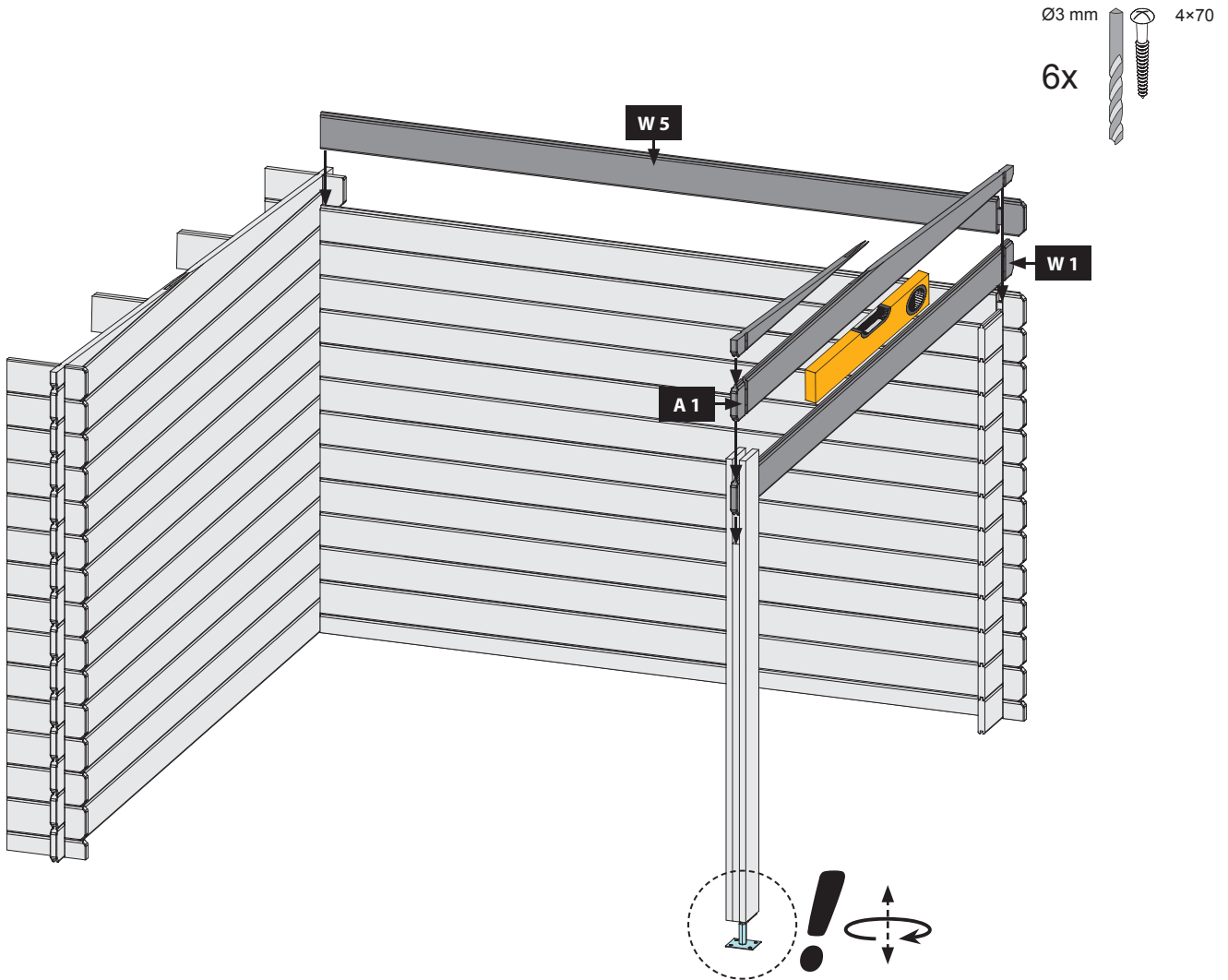
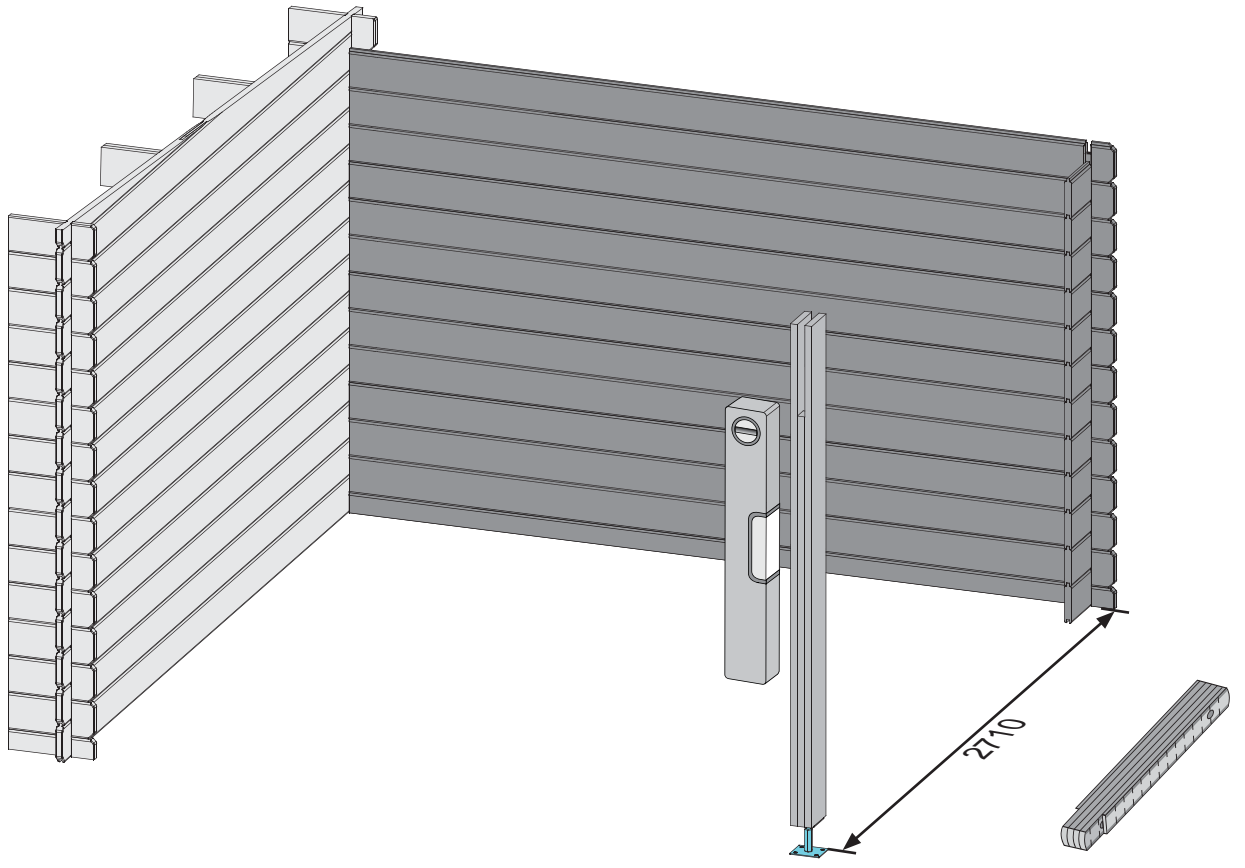

-  Bündig!
-  Flush!
-  Affleurement!
-  Gelijk!
-  I flugt!
-  Aras!
-  Combacia!
-  Stejný !

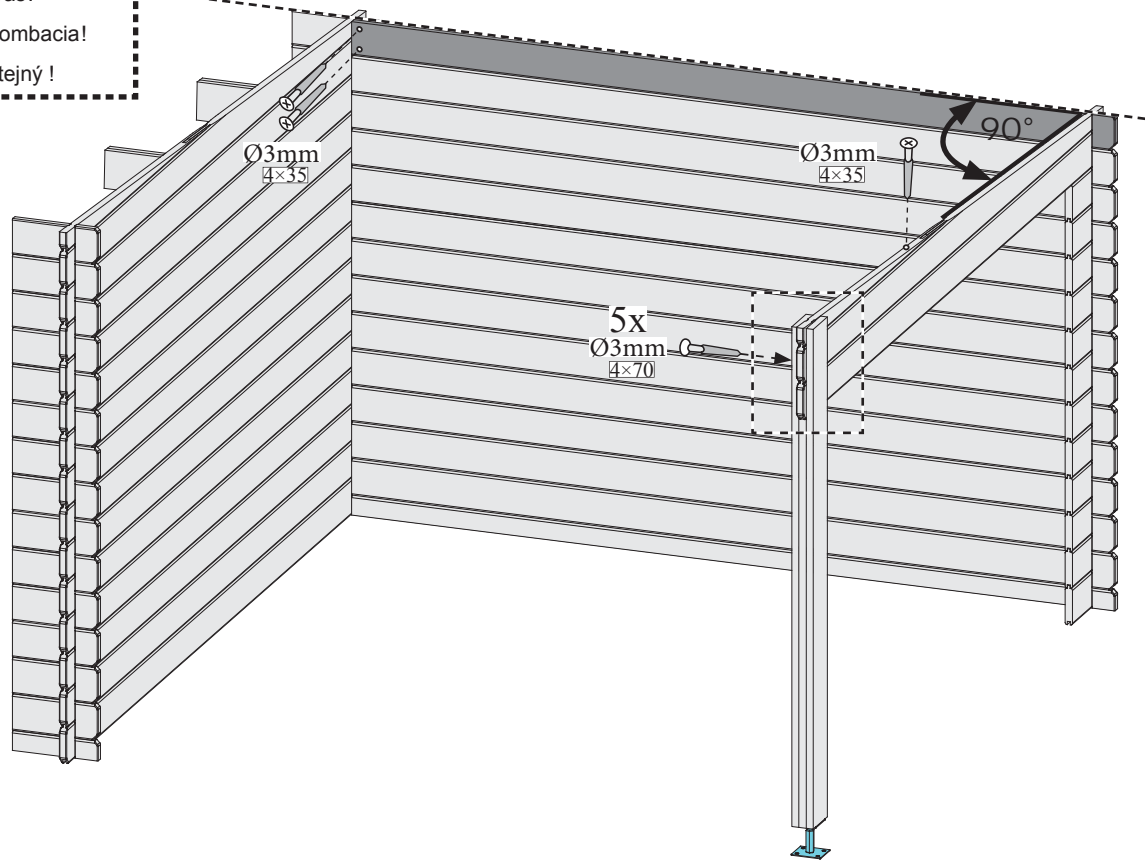
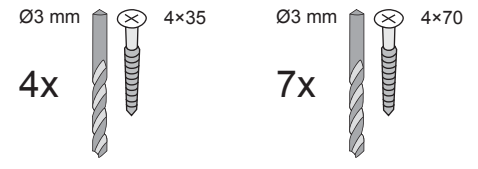

-  Bündig!
-  Flush!
-  Affleurement!
-  Gelijk!
-  I flugt!
-  Aras!
-  Combacia!
-  Stejný !

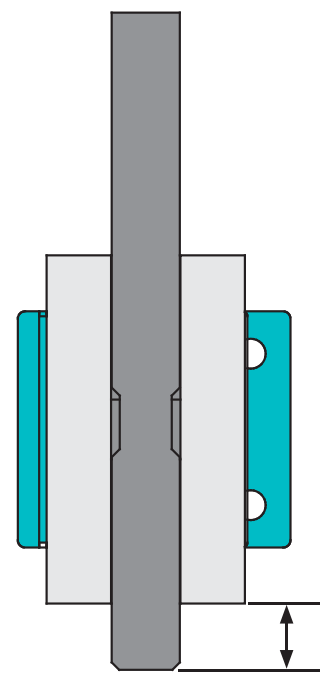
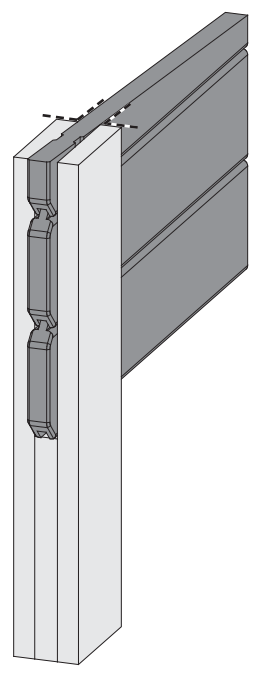

-  Draufsicht
-  Top view
-  vue de dessus
-  bovenaanzicht
-  vista desde arriba
-  vista desde arriba
-  vista dall'alto
-  pŮdorys

Ø3 mm 4x60
6x

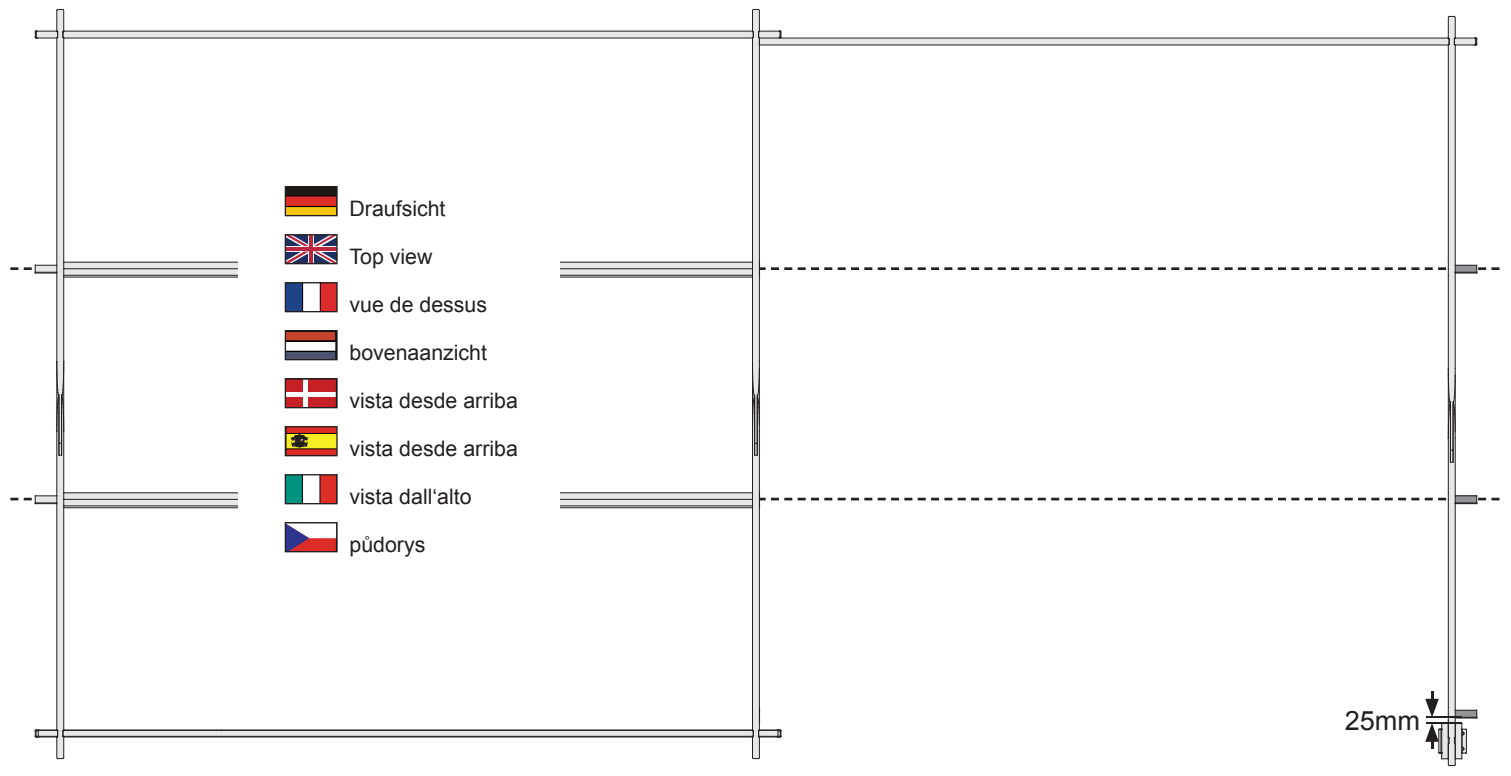
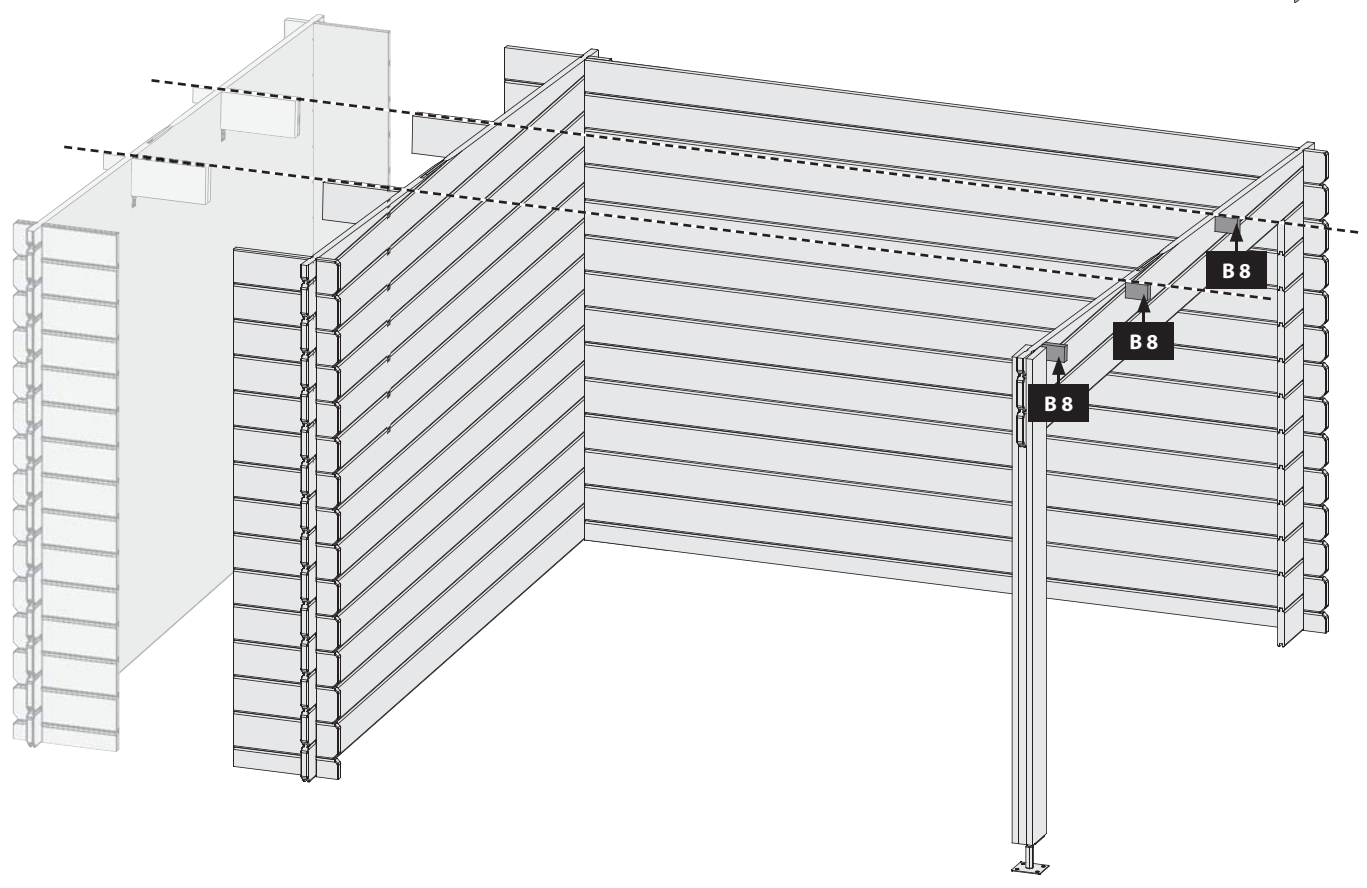

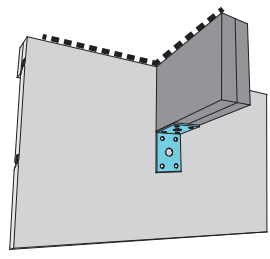
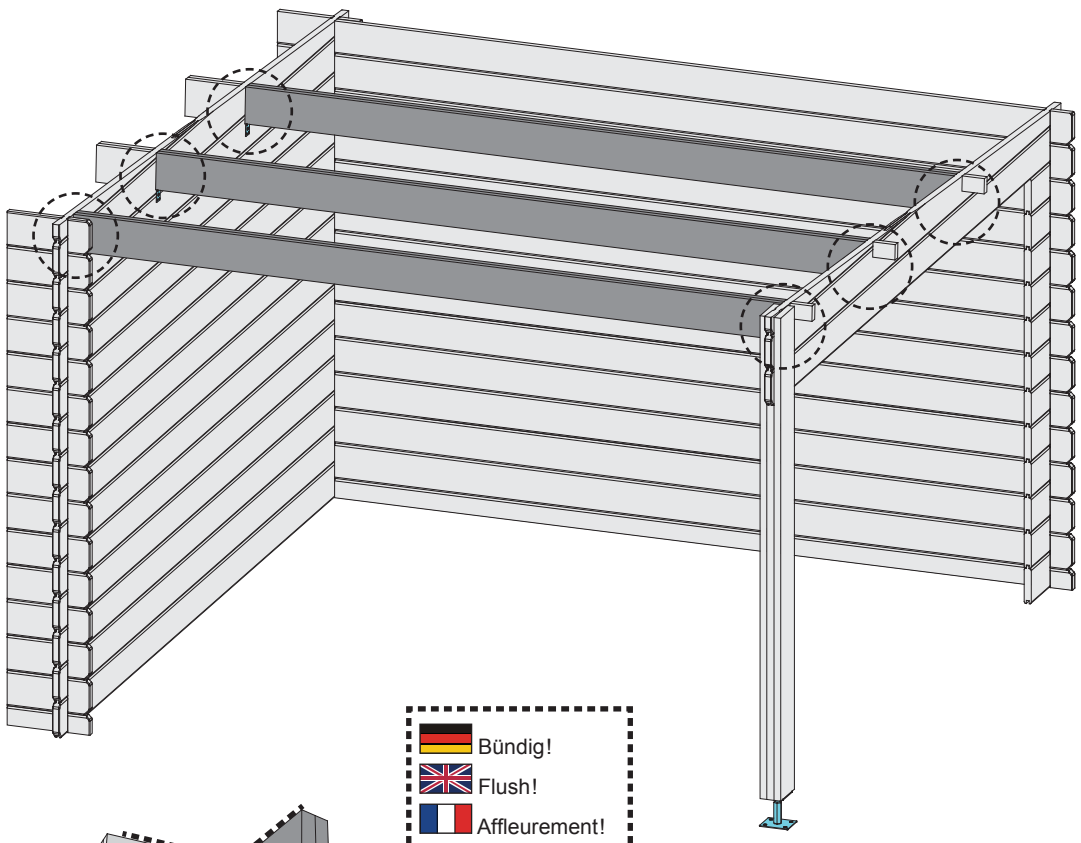
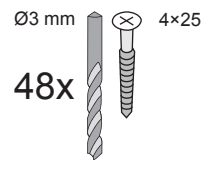
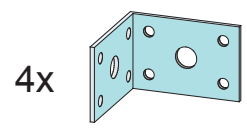

-  Bündig!
-  Flush!
-  Affleurement!
-  Gelijk!
-  I flugt!
-  Aras!
-  Combacia!
-  Stejný !

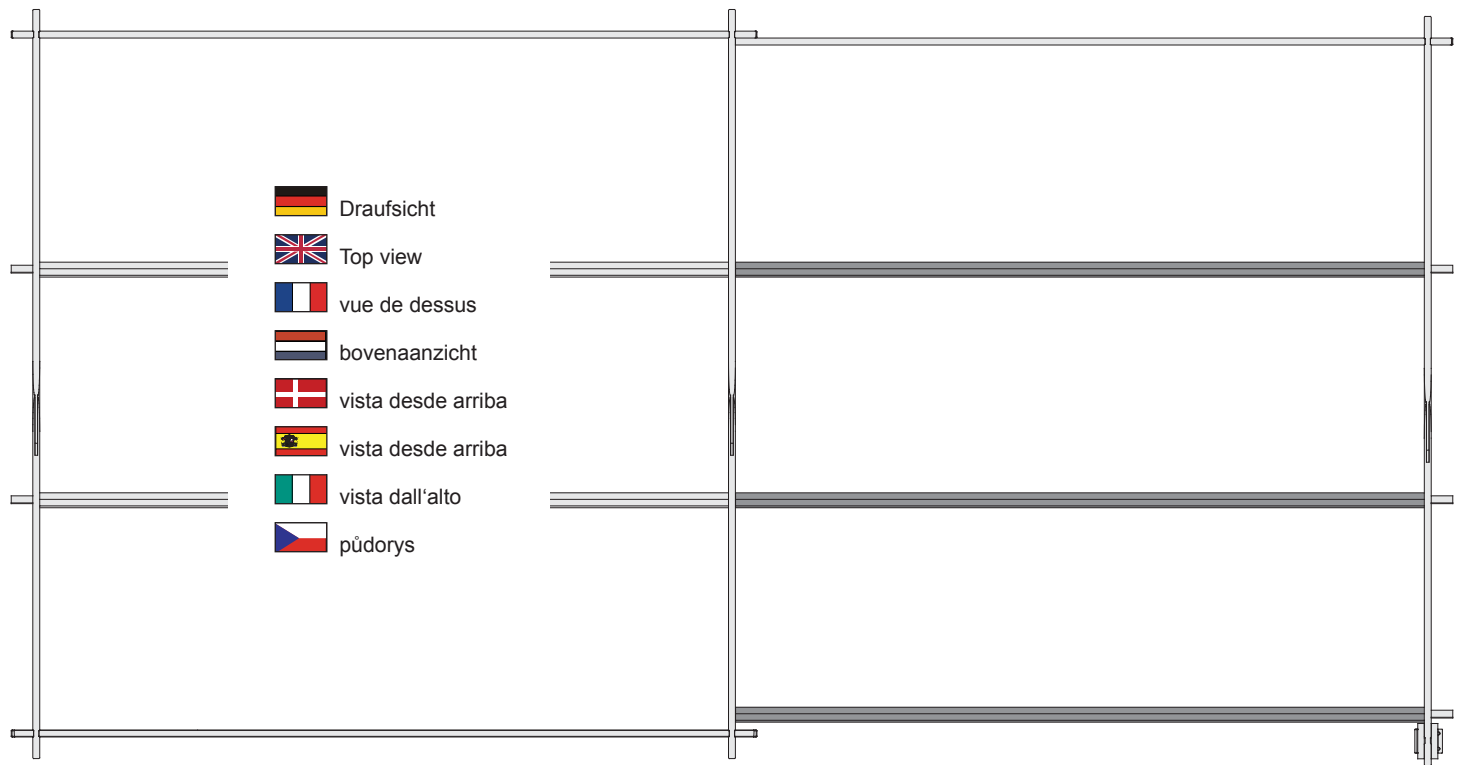

-  Draufsicht
-  Top view
-  vue de dessus
-  bovenaanzicht
-  vista desde arriba
-  vista desde arriba
-  vista dall'alto
-  pùdorys

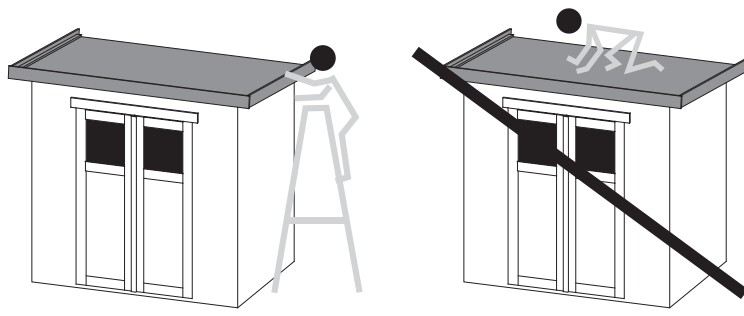

16

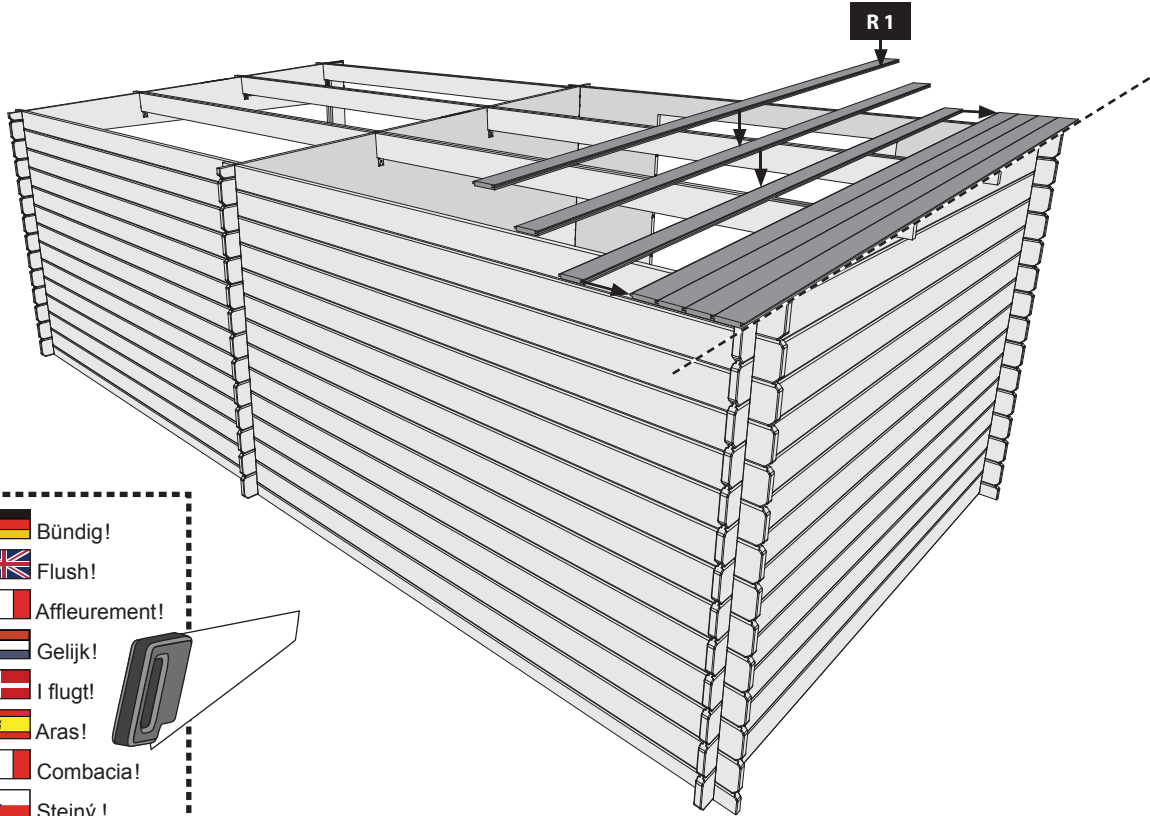

-  Bündig!
-  Flush!
-  Affleurement!
-  Gelijk!
-  I flugt!
-  Aras!
-  Combacia!
-  Stejný!

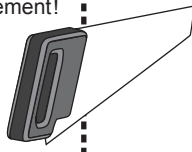

17

66x

528x

2,2x50

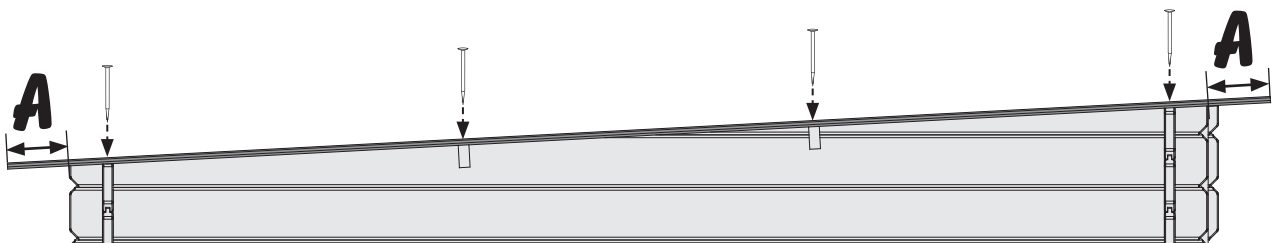
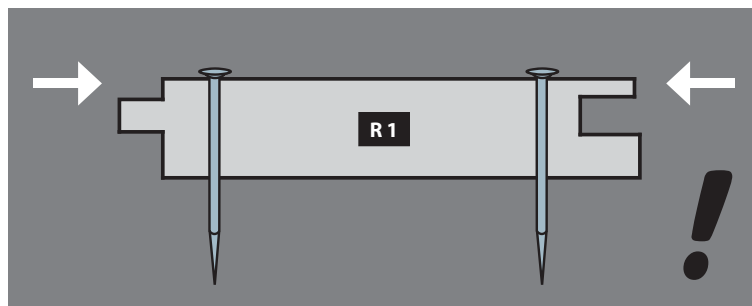

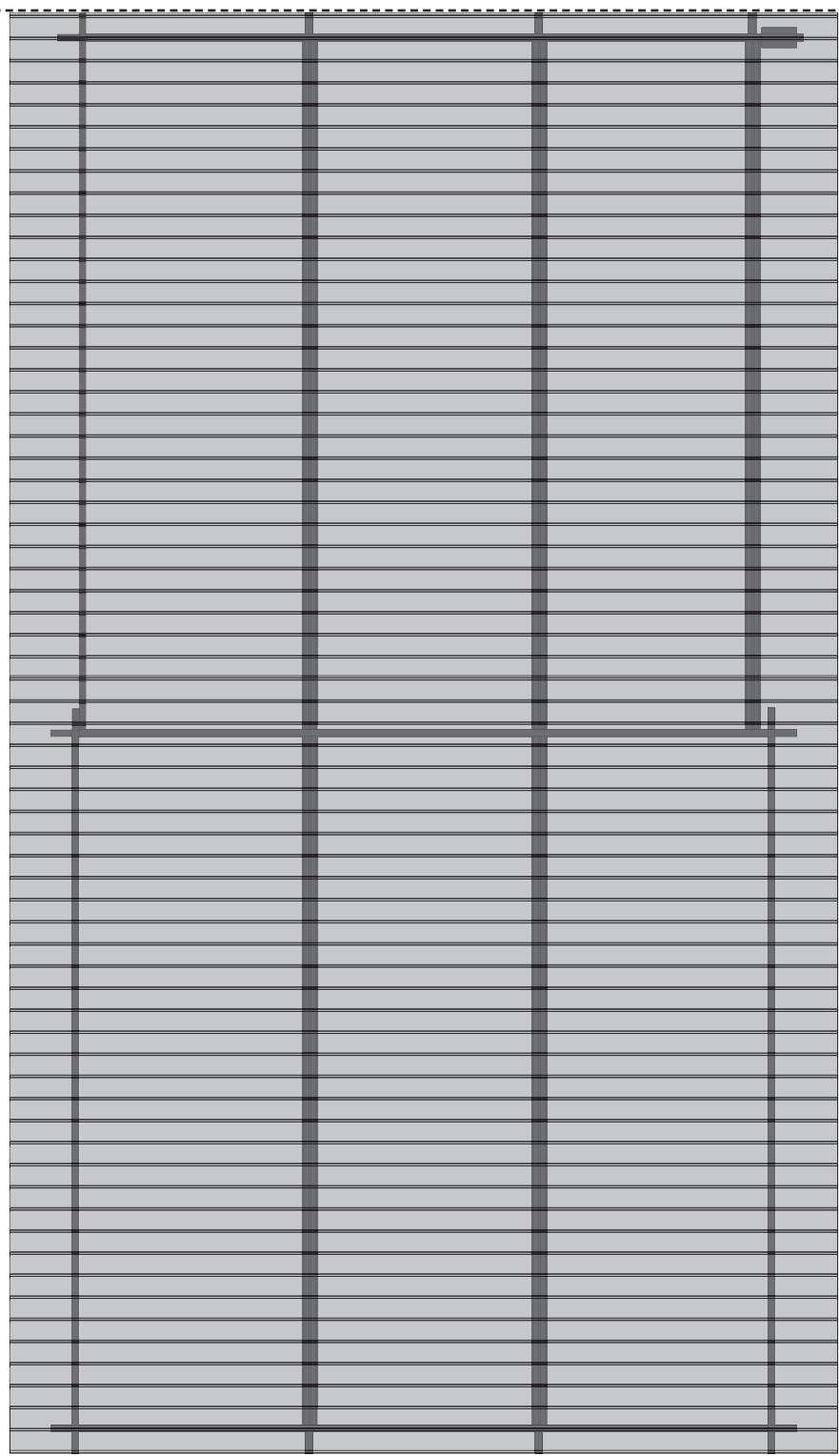
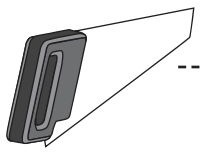

-  Bündig!
-  Flush!
-  Affleurement!
-  Gelijk!
-  I flugt!
-  Aras!
-  Combacia!
-  Stejný !

-  Draufsicht
-  Top view
-  vue de dessus
-  bovenaanzicht
-  vista desde arriba
-  vista desde arriba
-  vista dall'alto
-  pŮdorys

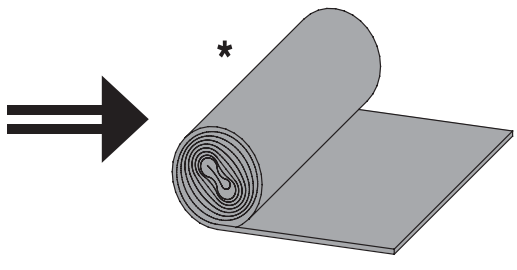

Wichtige Hinweise:

Bitte lesen Sie die Bedienungsanleitung sorgfältig durch, bevor Sie die Rollläden installieren. Die Rollläden sind für den Einsatz in Wohnräumen, Büros und öffentlichen Gebäuden geeignet. Die Rollläden sind für den Einsatz in Wohnräumen, Büros und öffentlichen Gebäuden geeignet. Die Rollläden sind für den Einsatz in Wohnräumen, Büros und öffentlichen Gebäuden geeignet.

Wichtige Hinweise:

Bitte lesen Sie die Bedienungsanleitung sorgfältig durch, bevor Sie die Rollläden installieren. Die Rollläden sind für den Einsatz in Wohnräumen, Büros und öffentlichen Gebäuden geeignet. Die Rollläden sind für den Einsatz in Wohnräumen, Büros und öffentlichen Gebäuden geeignet. Die Rollläden sind für den Einsatz in Wohnräumen, Büros und öffentlichen Gebäuden geeignet.

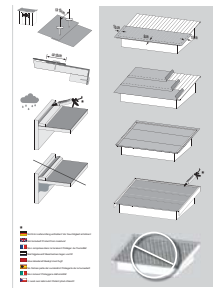

20

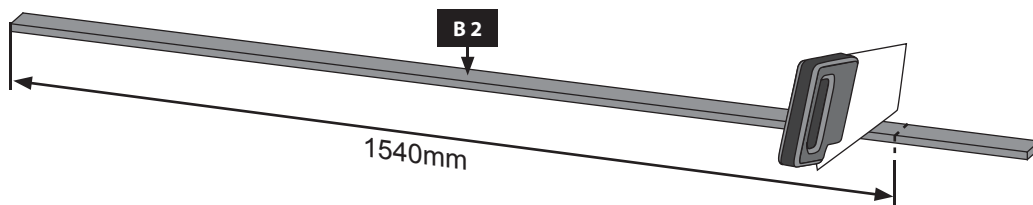

21

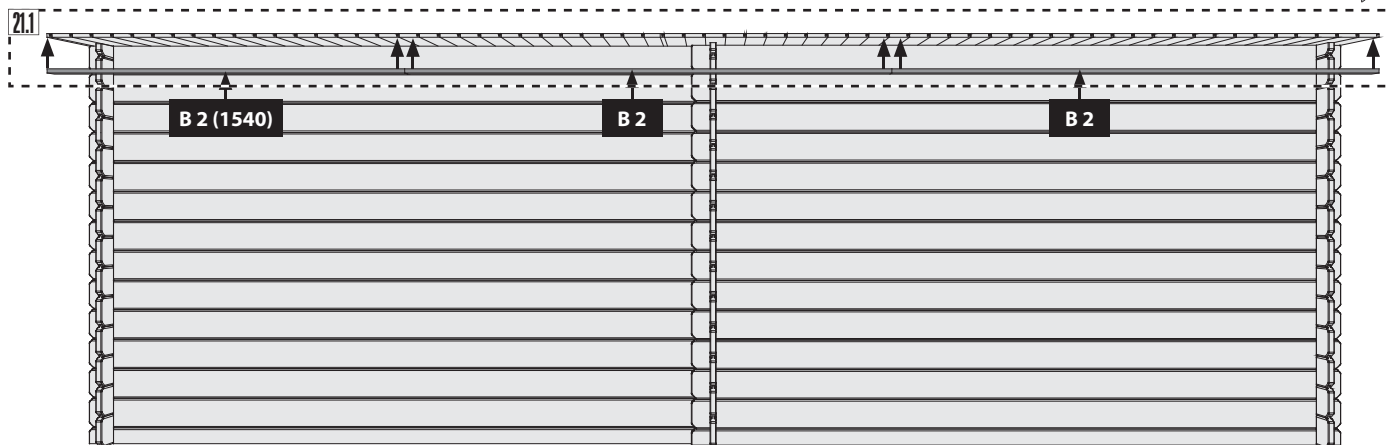
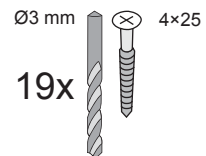

21.1

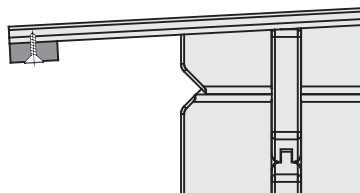

-  Seitenwand
-  Side wall
-  paroi latérale
-  zijwand
-  sidevæg
-  pared lateral
-  parete laterale
-  boční stěna

22.1

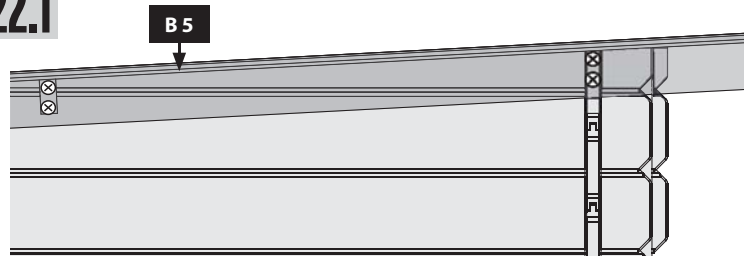

22

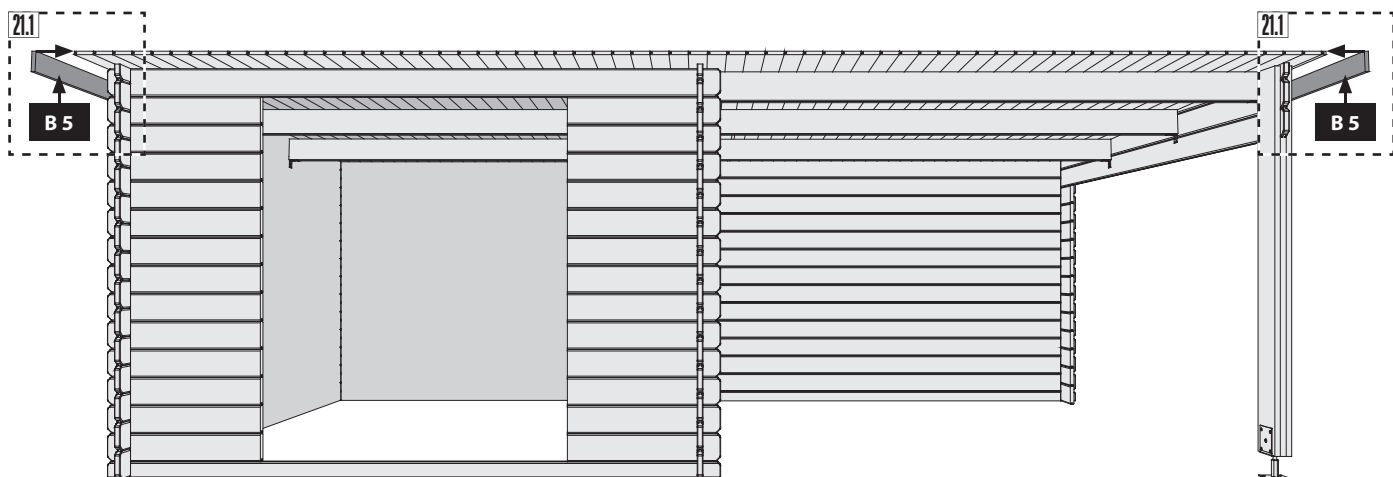
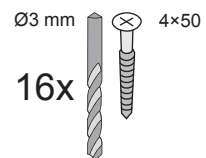

23

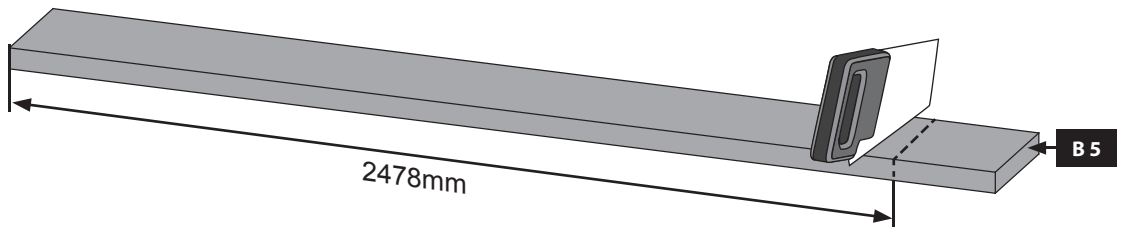

24

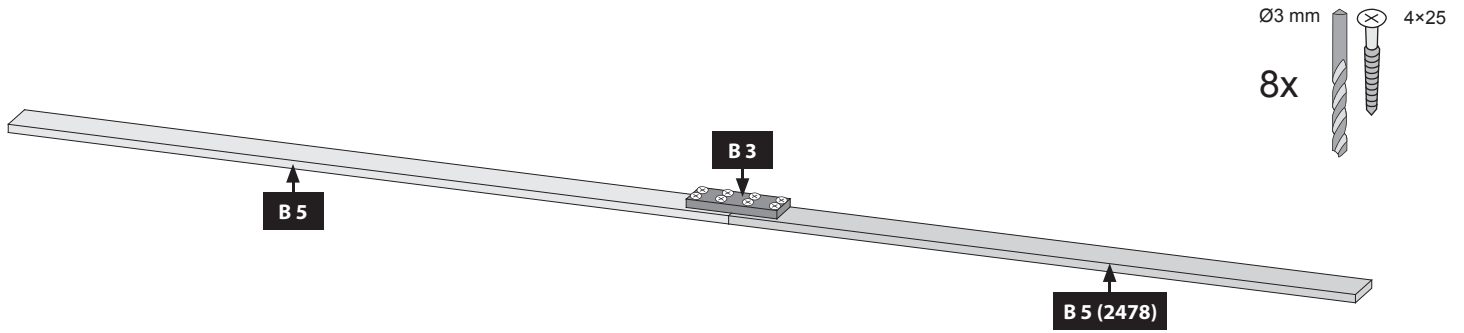

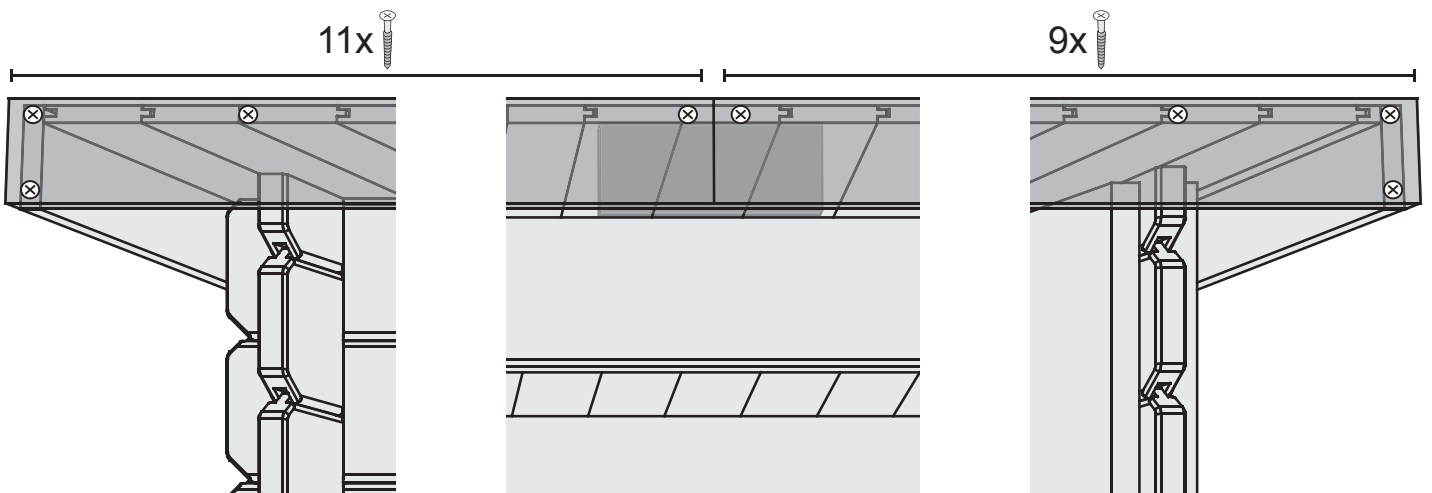
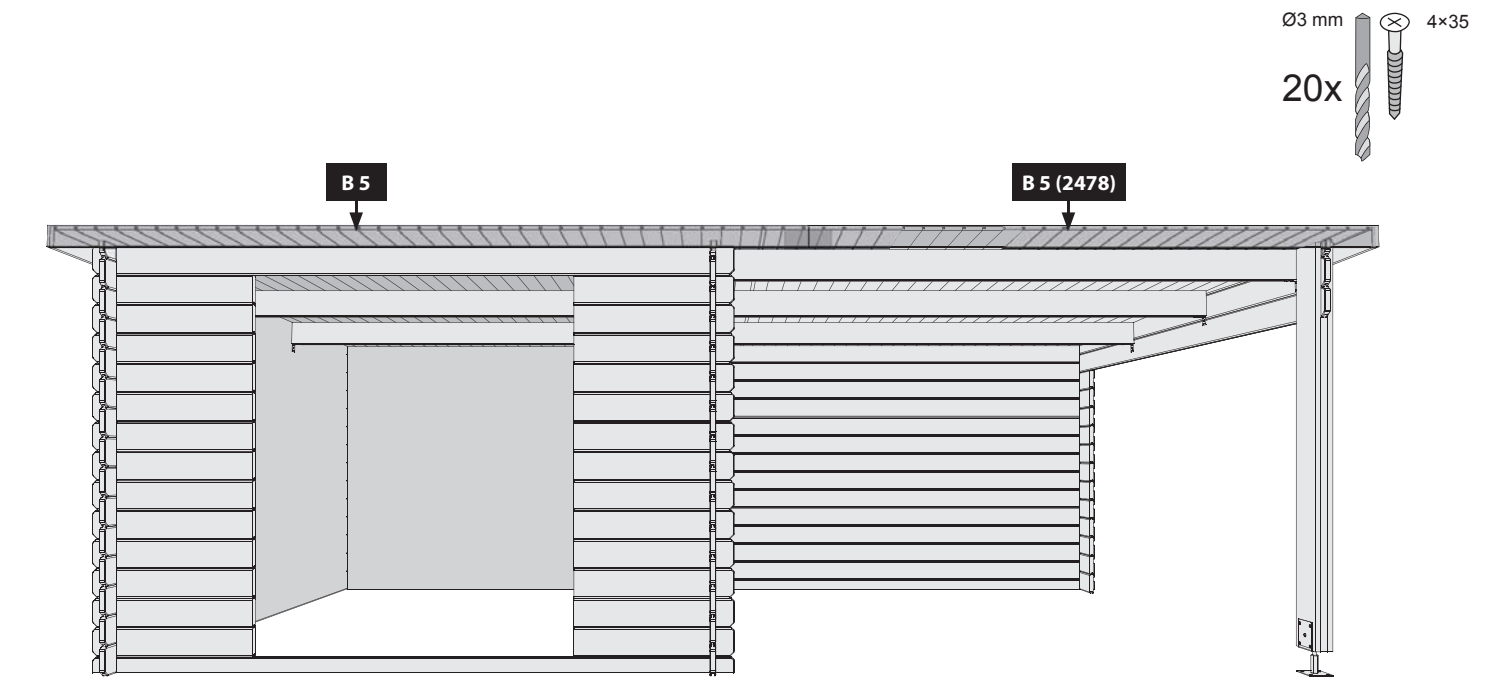

25

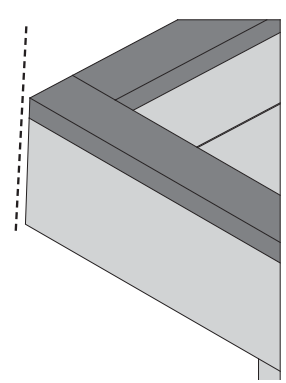
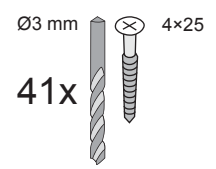
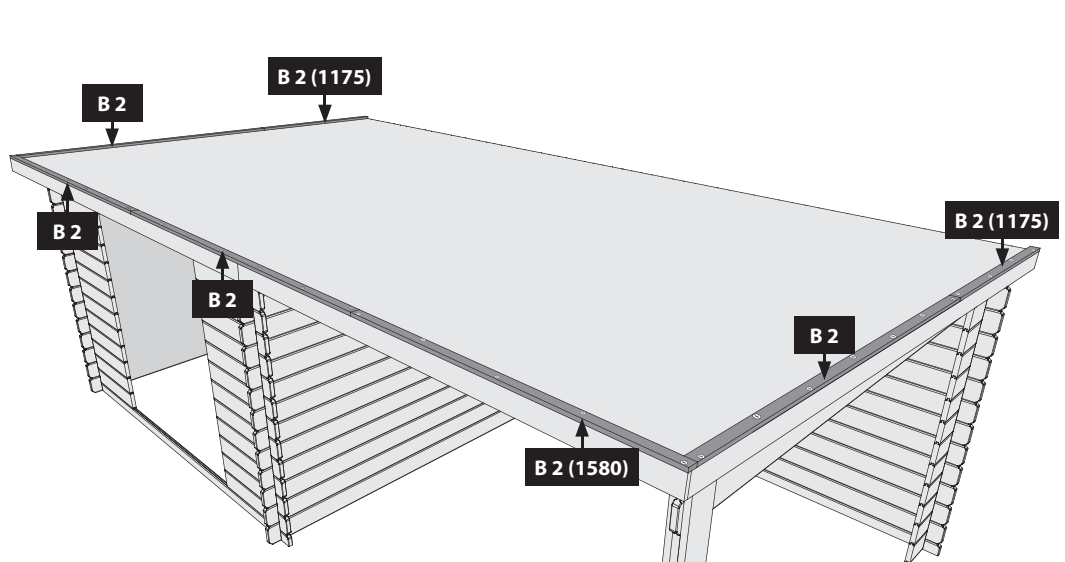
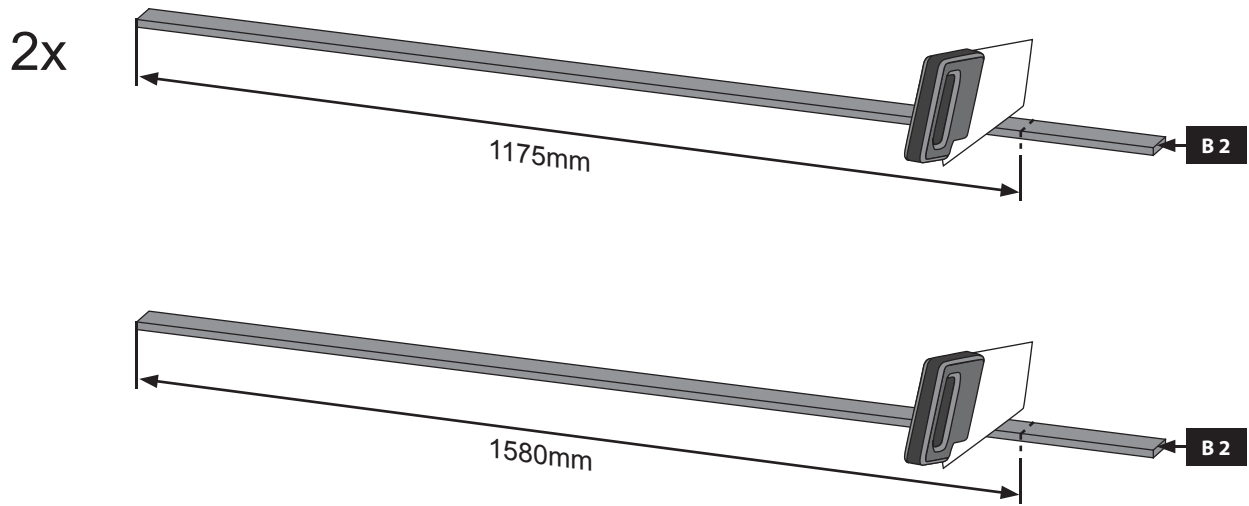

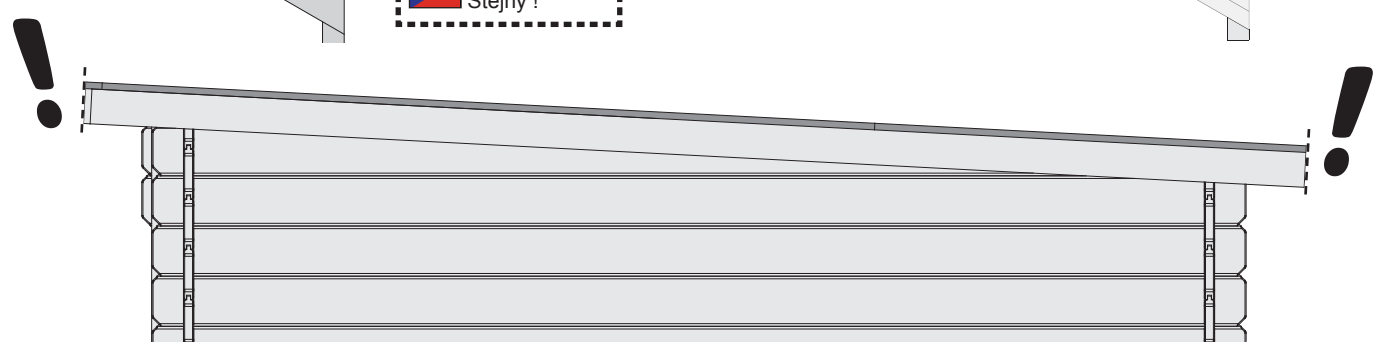
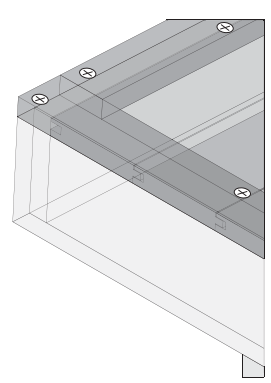

-  Bündig!
-  Flush!
-  Affleurement!
-  Gelijk!
-  I flugt!
-  Aras!
-  Combacia!
-  Stejný !



 Einbau Tür

 Installation door

 Porte d'installation

 Installatie deur

 Installationsdør

 Puerta de instalación

 Porta di installazione

 Montážní dveře

28

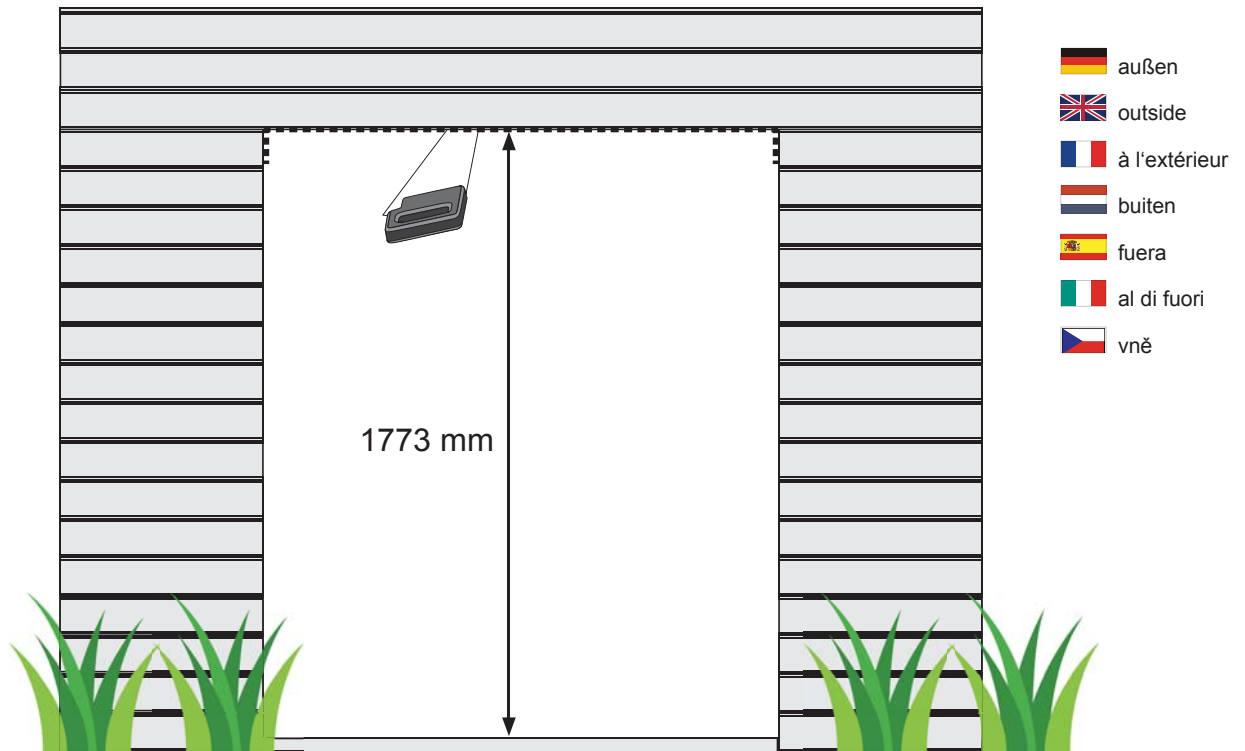

29

-  Bündig!
-  Flush!
-  Affleurement!
-  Gelijk!
-  I flugt!
-  Aras!
-  Combacia!
-  Stejný!

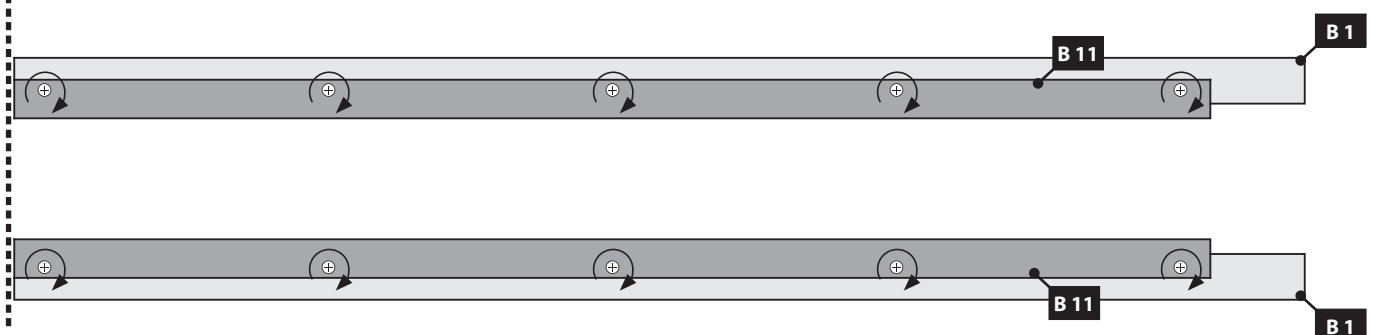
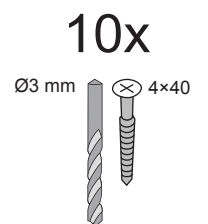
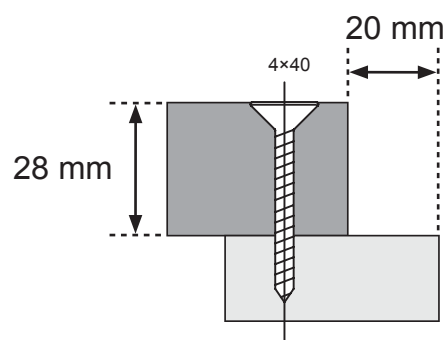

9x

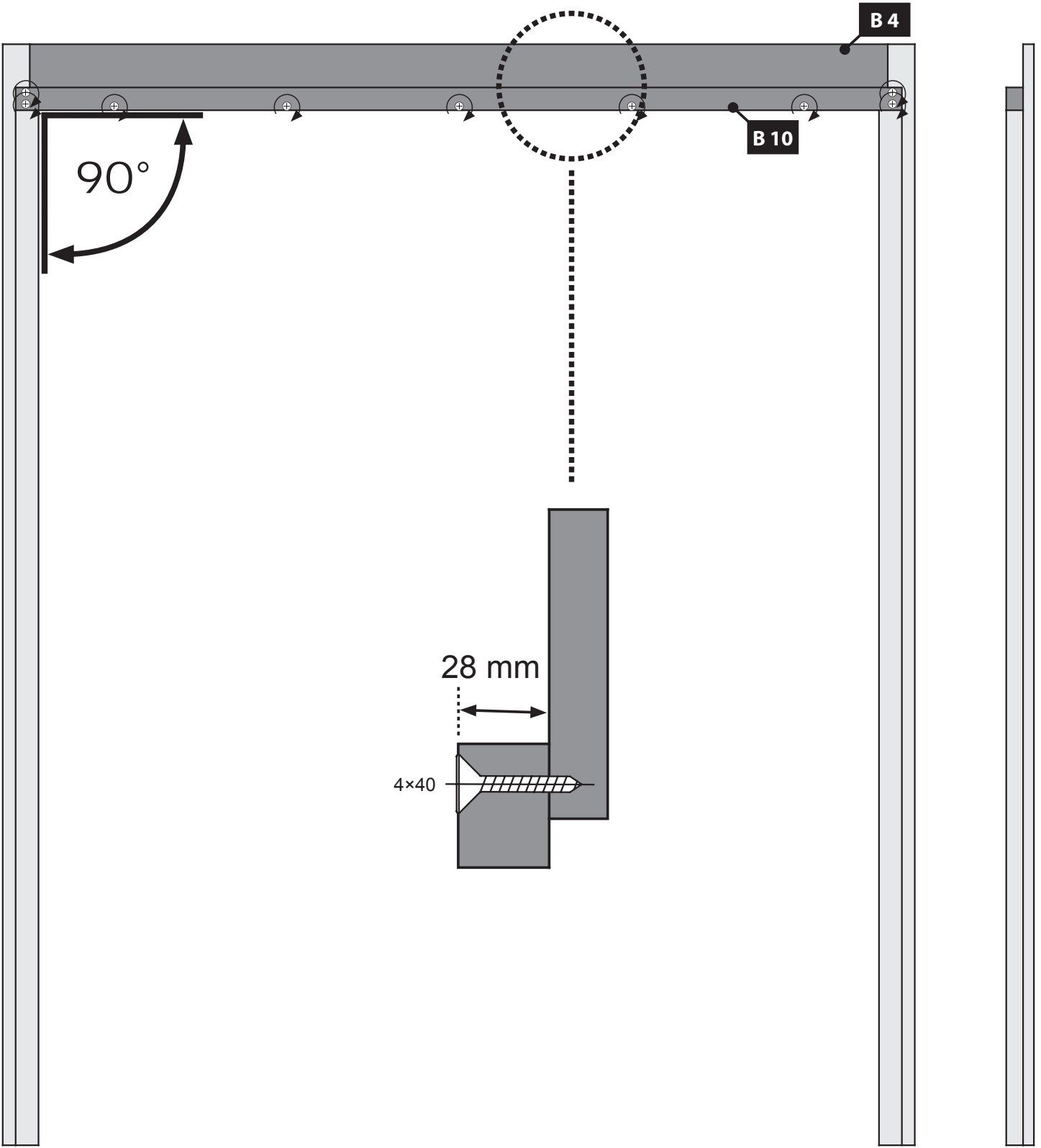
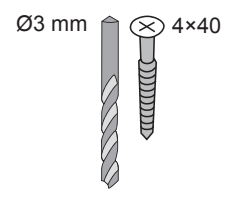

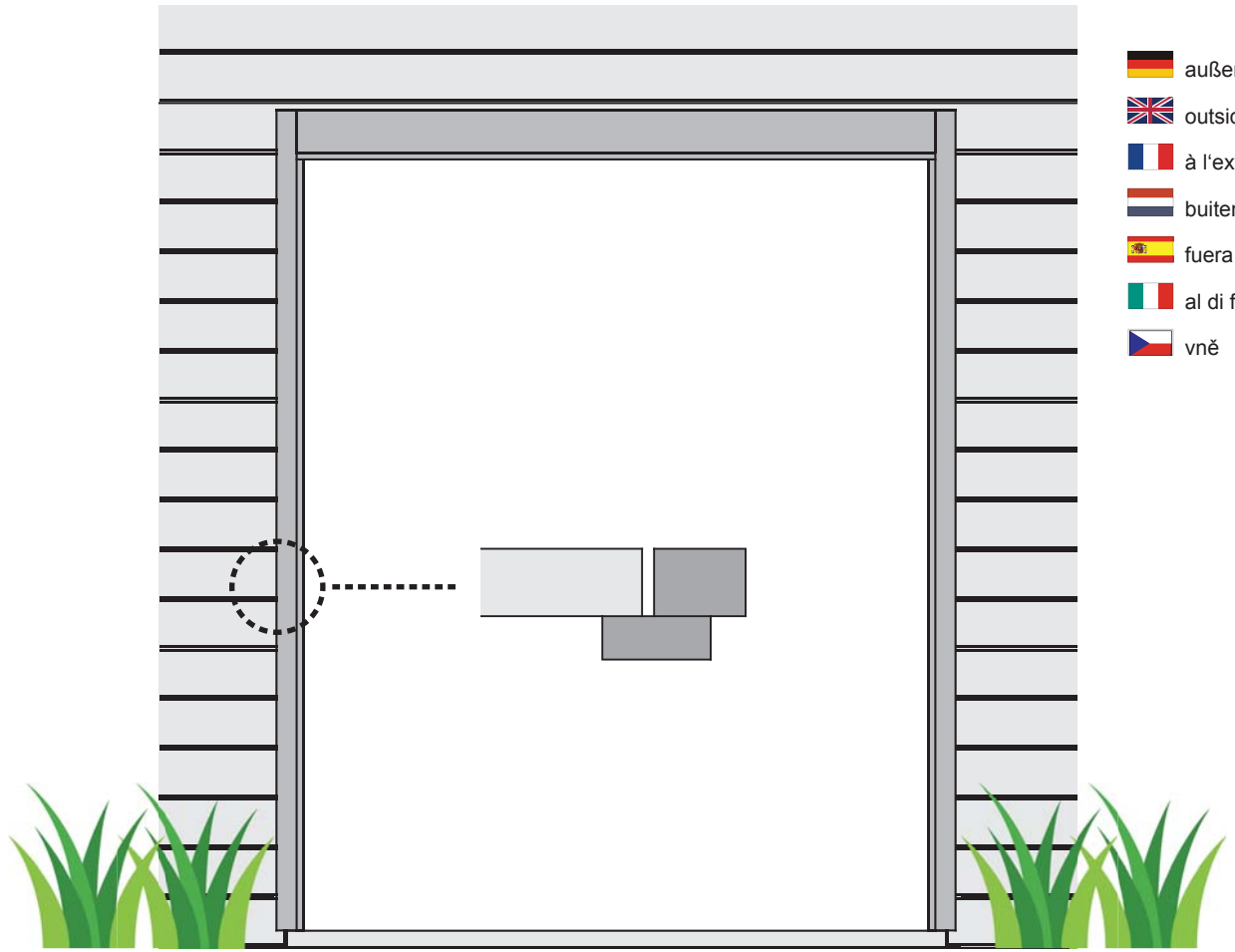



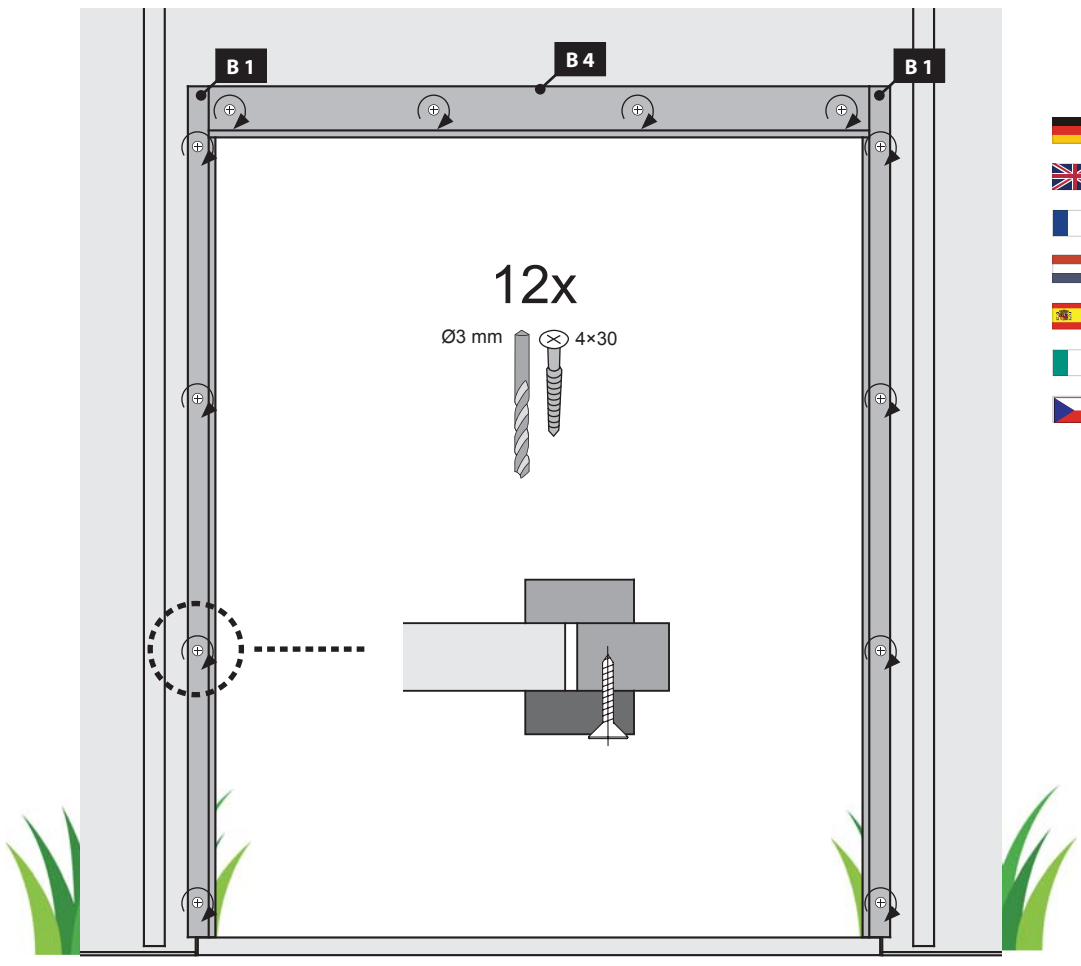





-  außen
-  outside
-  à l'extérieur
-  buiten
-  fuera
-  al di fuori
-  vně



-  innen
-  Inside
-  à l'intérieur
-  binnen
-  dentro
-  dentro
-  uvnitř

- | | | |
|--|--|---|
|  Schutzfolie abziehen |  Verwijder de beschermende film |  Rimuovere la pellicola protettiva |
|  Remove protective film |  Fjern beskyttelsesfilm |  Odstraňte ochranný film |
|  Retirer le film protecteur |  Retire la película protectora | |

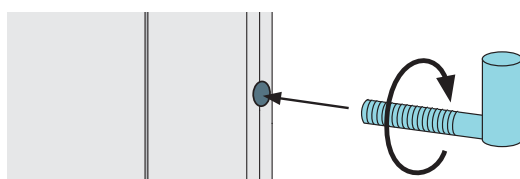
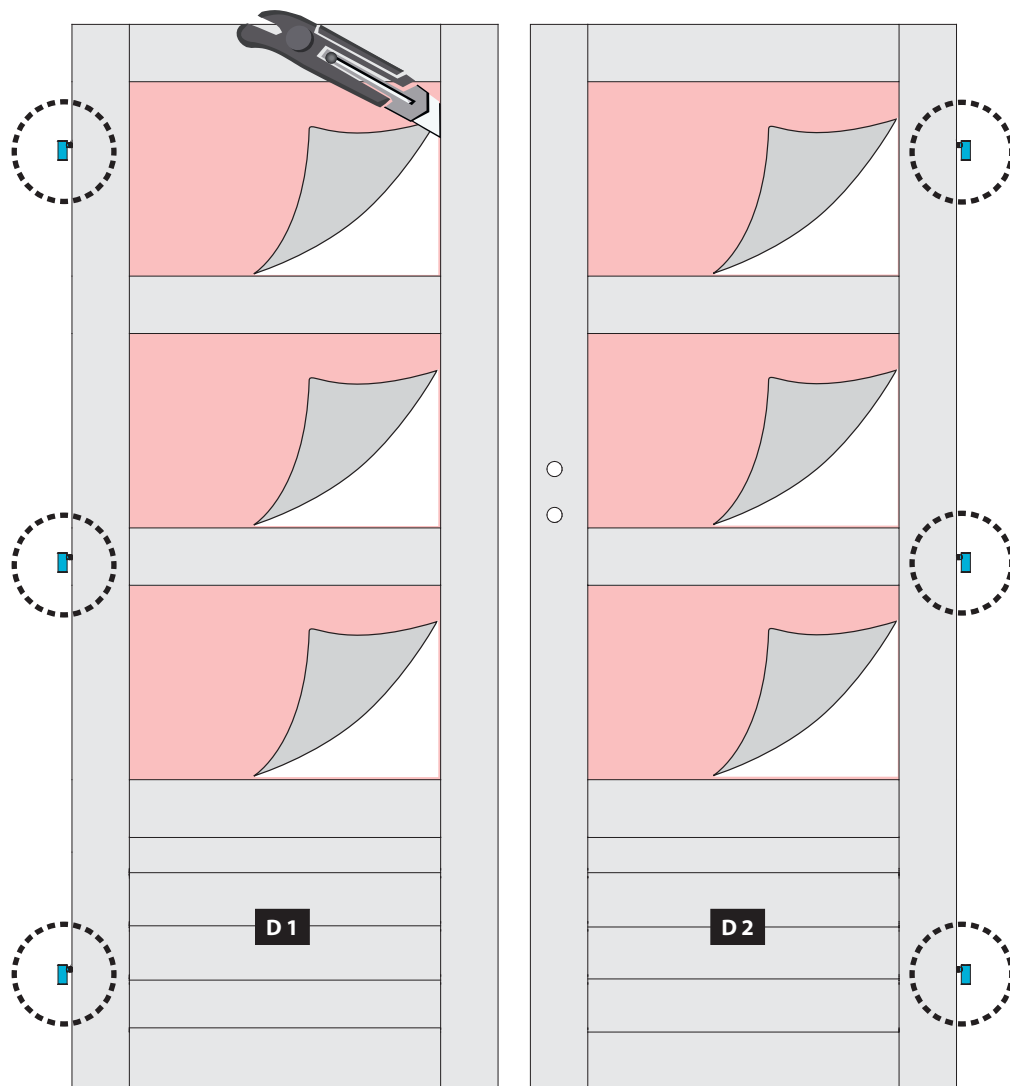

18x

Ø3 mm 4x30

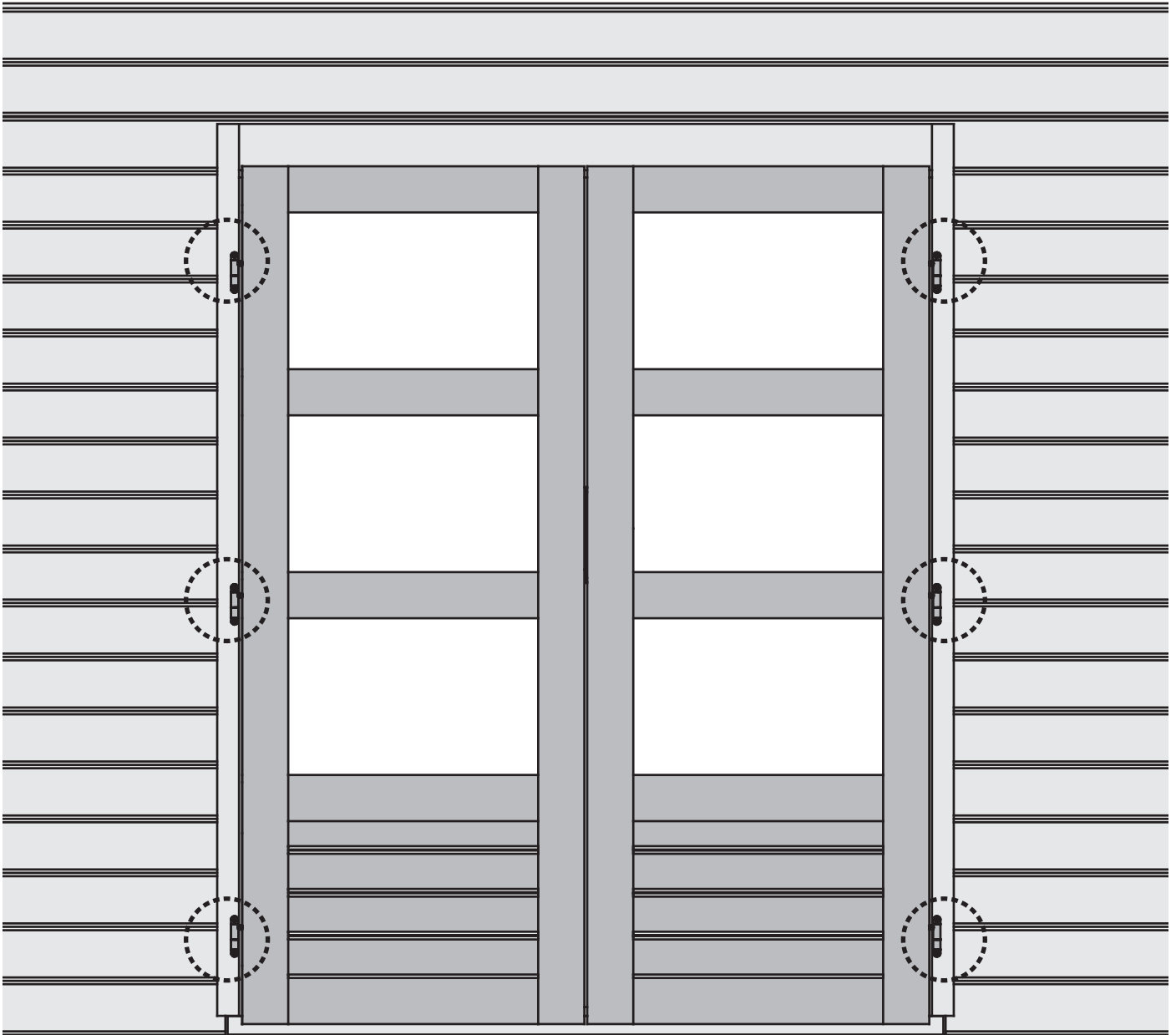
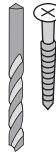

1.

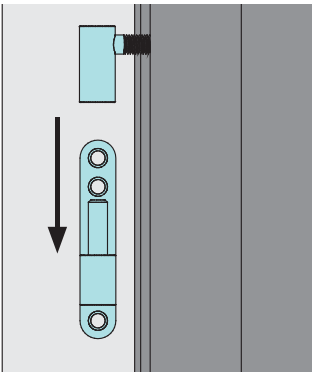

2.

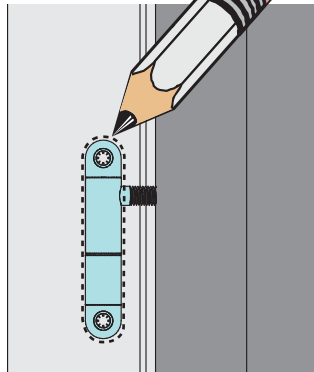

3.

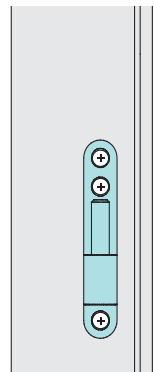

5x

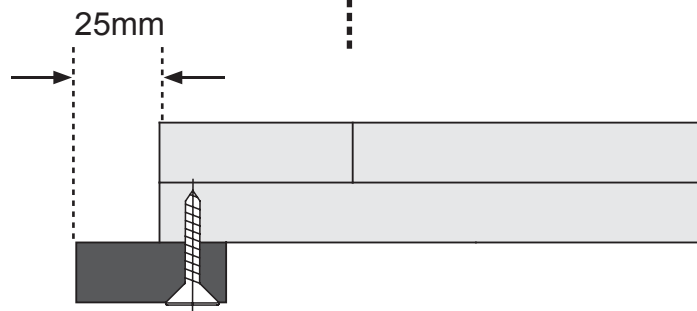
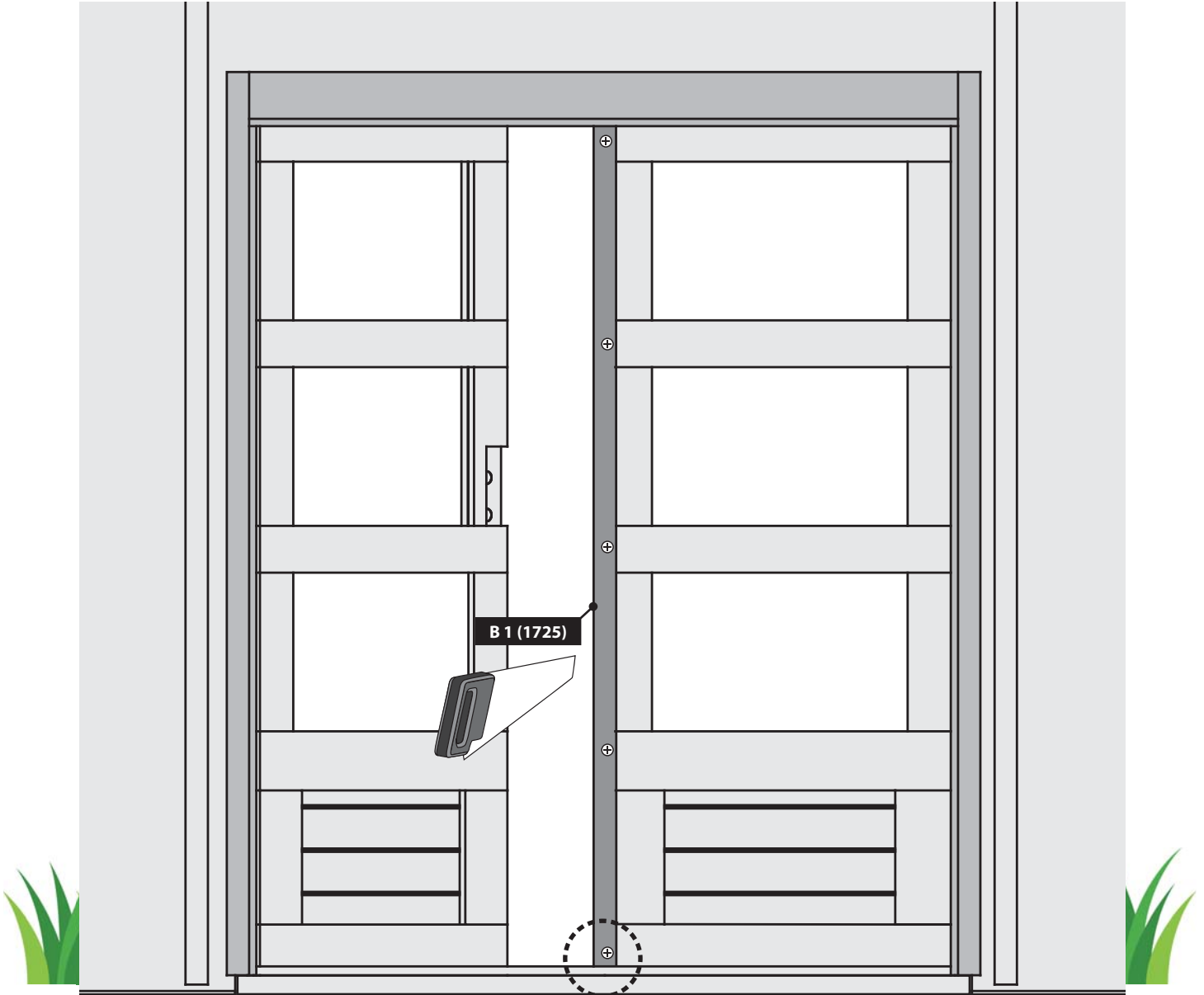
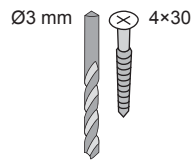

8x

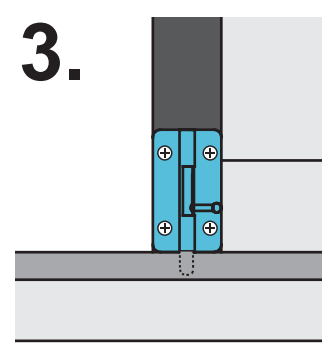
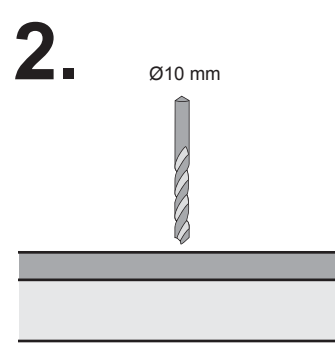
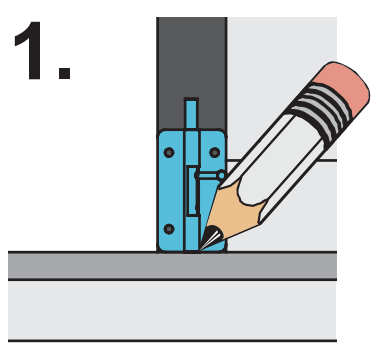
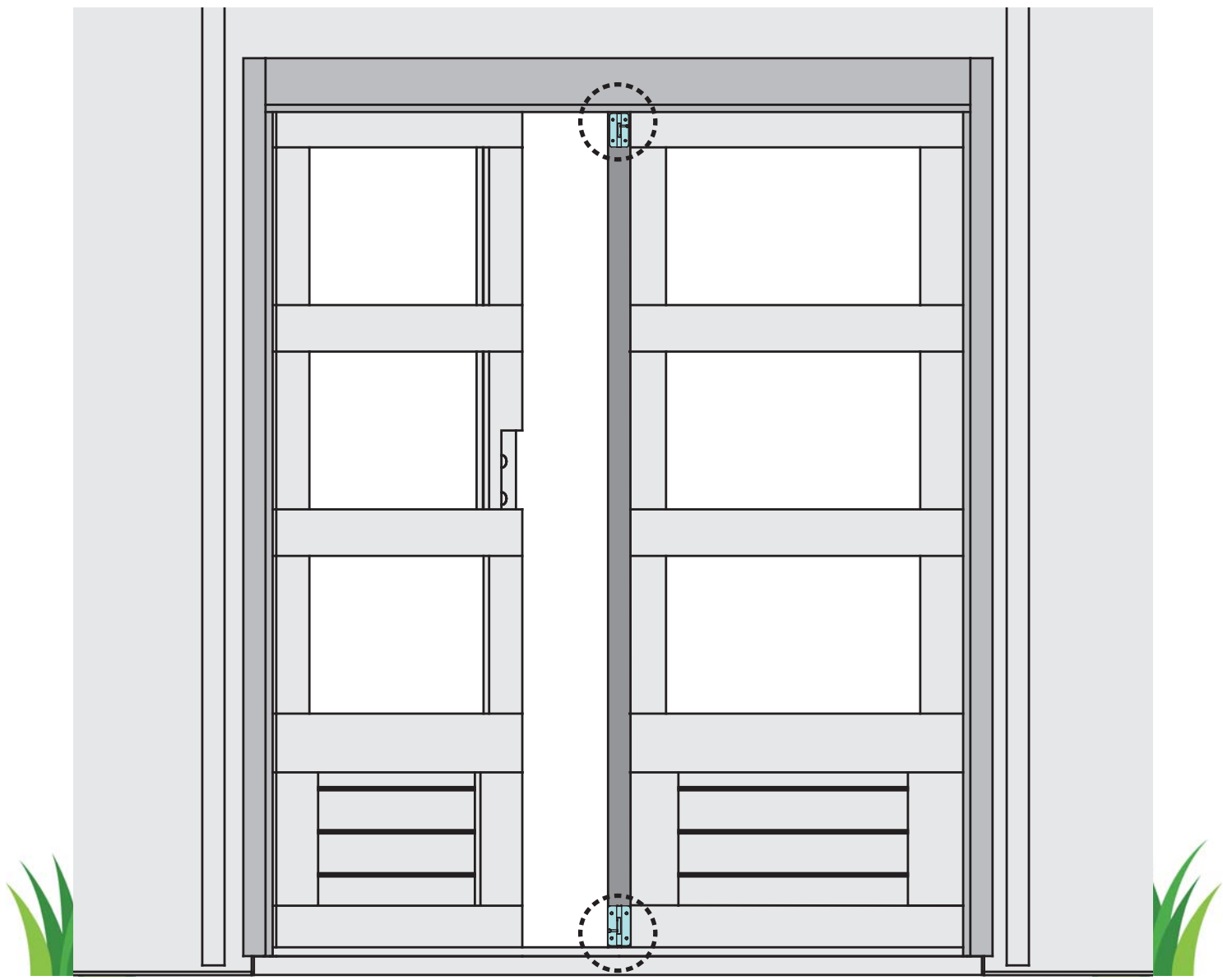
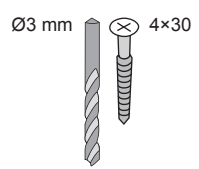

12x

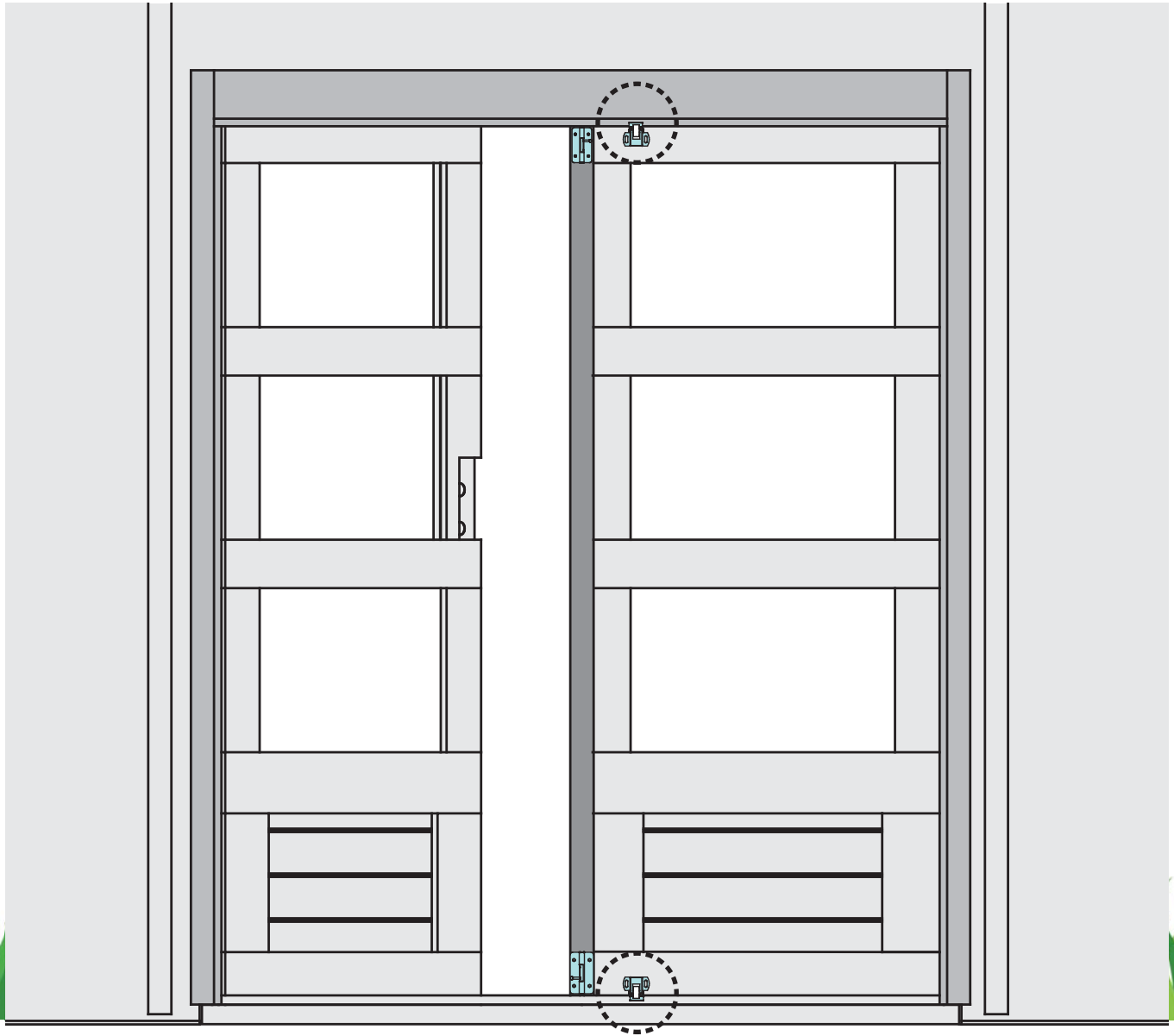
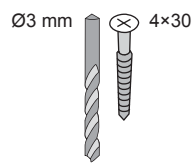

1.

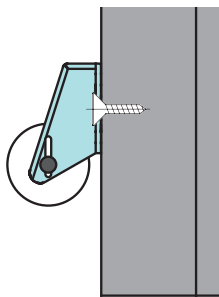

2.

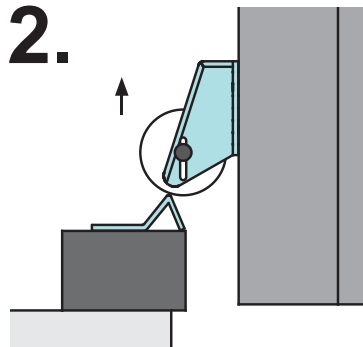

3.

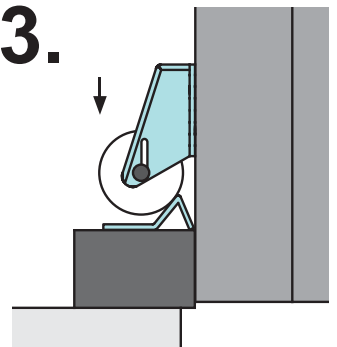

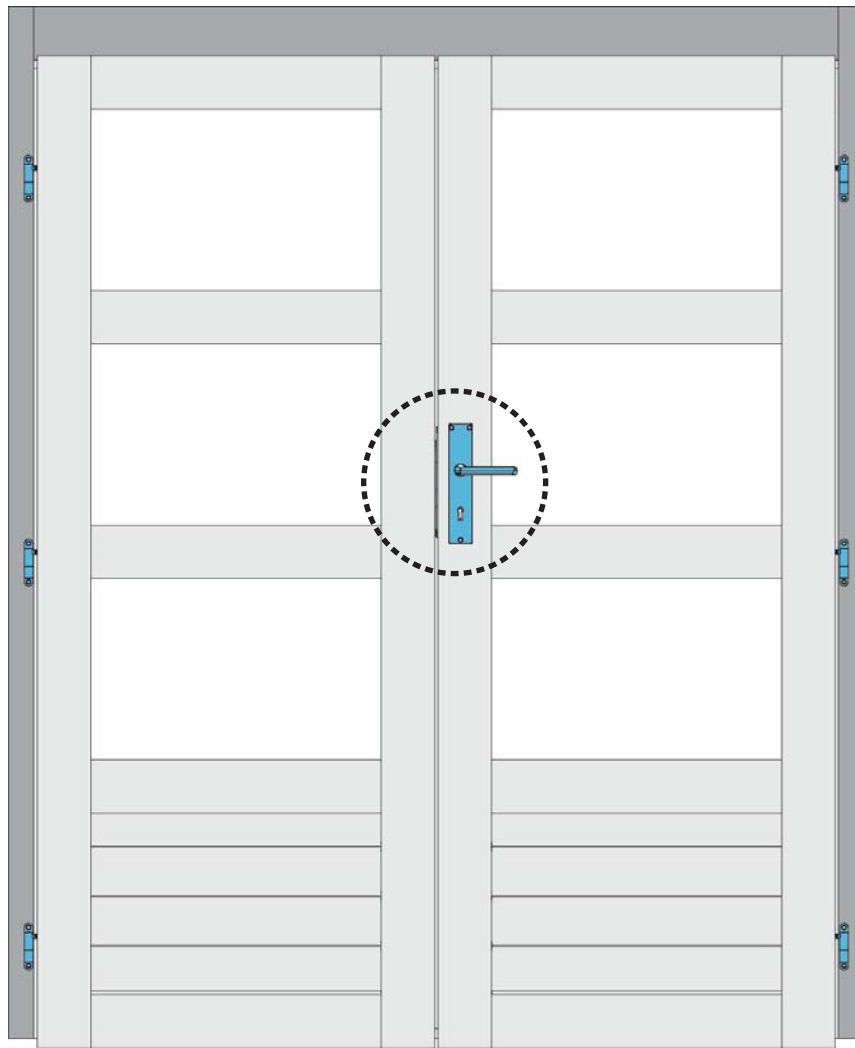

Ø3 mm

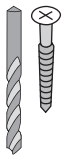

12x

