

45638

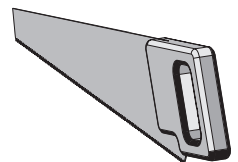
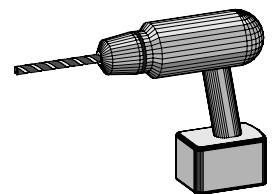
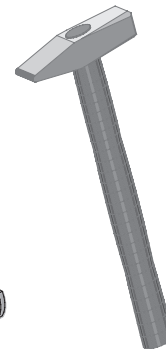
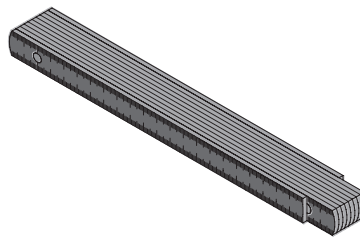
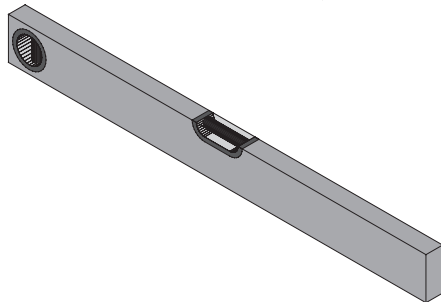
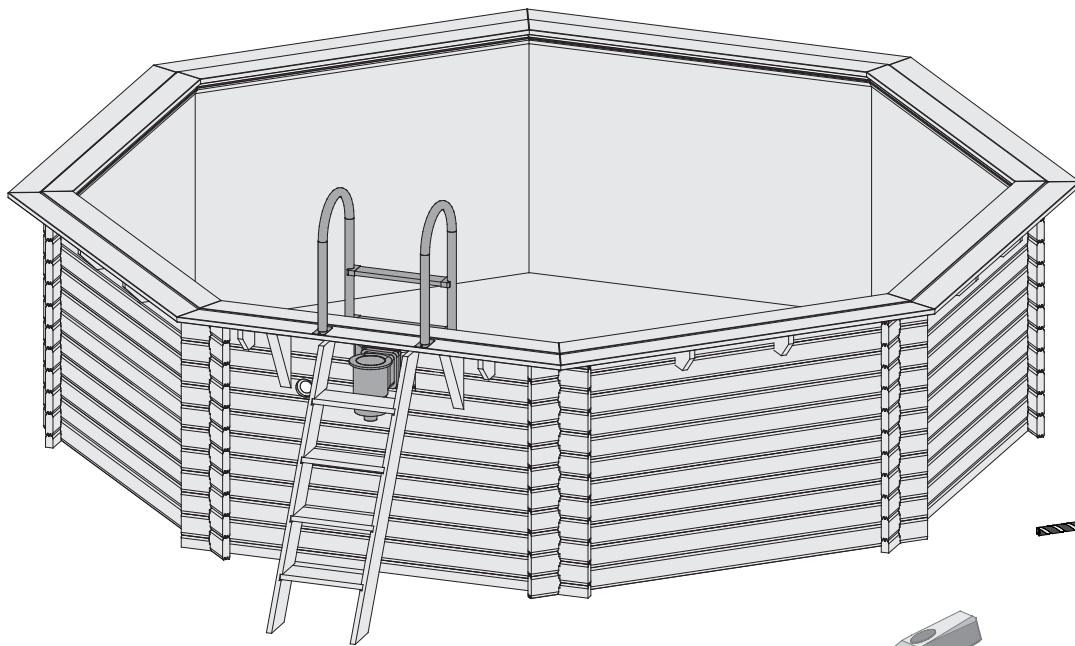

 **Aufbauanleitung**

 **notice de montage**

 **Building Instructions**

 **montagehandleiding**

 **Instrucciones de construcción**

 **Istruzioni per il montaggio**

 **Service-Hotline: +49 421 38693 33**



Vergleichen Sie zuerst die Materialliste mit Ihrem Paketinhalt! Bitte haben Sie Verständnis, dass Beanstandungen nur im nicht aufgebauten Zustand bearbeitet werden können!



Commencez par comparer la liste du matériel avec le contenu de votre paquet! Sachez que nous traitons uniquement les réclamations concernant le matériel à l'état non monté!



First compare the list of materials with your package contents! Please understand that complaints can be processed in the non-built status only!



Vergelijk eerst de lijst van materialen met de inhoud van uw pakket! Reclamaties kunnen alleen in behandeling worden genomen zolang de onderdelen nog niet zijn gemonteerd!



En primer lugar, compare la lista de material con el contenido del paquete. Rogamos entienda que las reclamaciones sólo pueden ser tramitadas antes de montar el objeto!



Confrontate questa distinta materiali prima con il contenuto del pacchetto! Vi preghiamo di comprendere che eventuali reclami possono essere accolti solo prima del montaggio!



45638

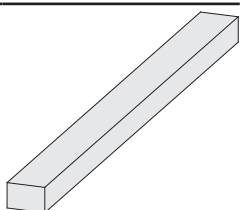

4 x B1	420 x 140 x 26mm	ID 39882
1 x B2	304 x 121 x 38mm	ID 39808

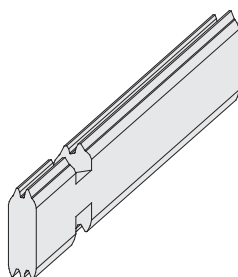

2 x W4	876 x 121 x 38mm	ID 39312
--------	------------------	----------

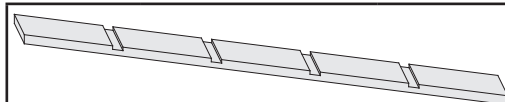

1 x M3	1417 x 140 x 26mm	ID 39880
--------	-------------------	----------

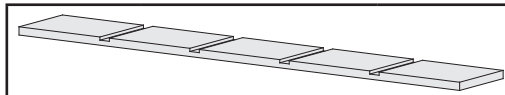

1 x M4	1417 x 140 x 26mm	ID 39881
--------	-------------------	----------

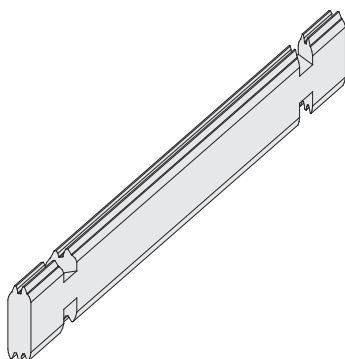

81 x W1	2062 x 121 x 38mm	ID 39277
---------	-------------------	----------

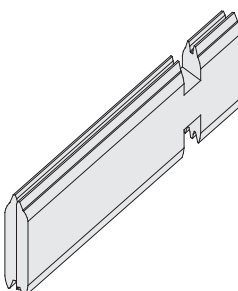

2 x W5	876 x 121 x 38mm	ID 39316
--------	------------------	----------

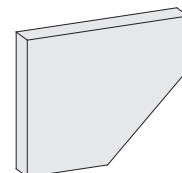

16 x M5	170 x 140 x 26mm	ID 42932
---------	------------------	----------

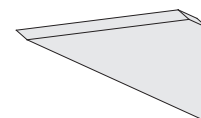

2 x M6	400 x 155 x 55mm	ID 72767
--------	------------------	----------

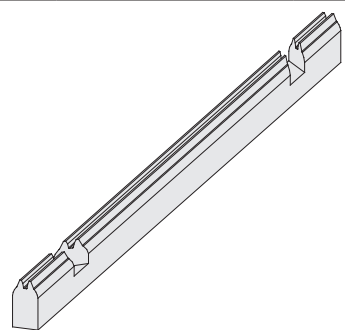

4 x W2	2062 x 71 x 38mm	ID 39366
--------	------------------	----------

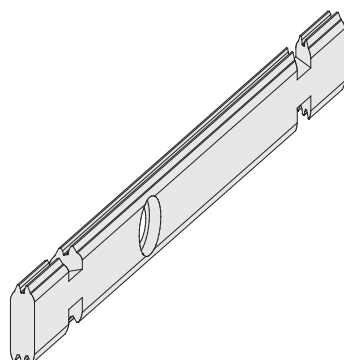

1 x W6	2062 x 121 x 38mm	ID 39343
--------	-------------------	----------

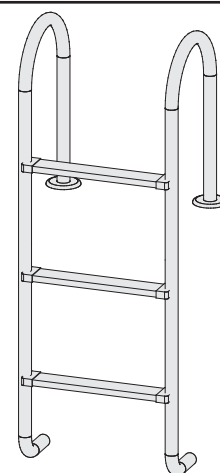

1 x	ID 39258
-----	----------

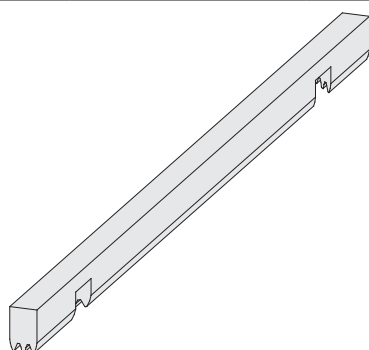

4 x W3	2062 x 60 x 38mm	ID 39287
--------	------------------	----------

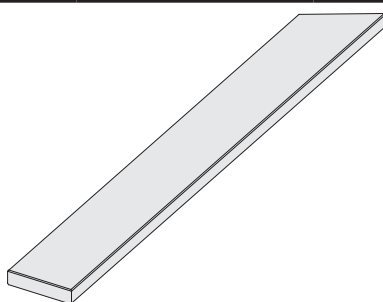

8 x M1	1826 x 140 x 26mm	ID 42940
8 x M2	1947 x 140 x 26mm	ID 42934

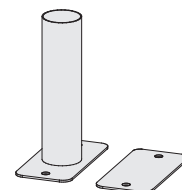

2 x	ID 39259
-----	----------

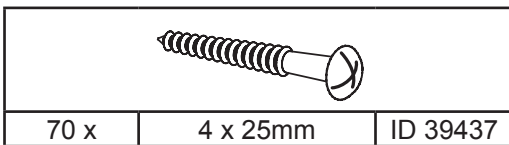
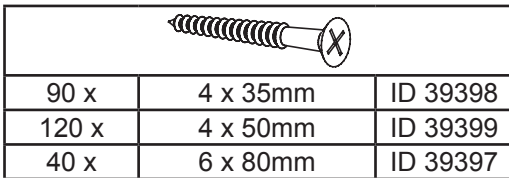
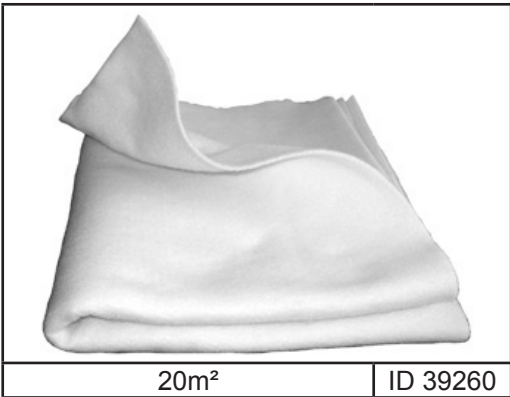
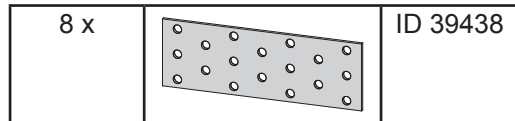
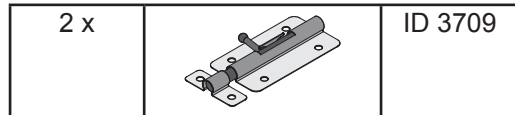
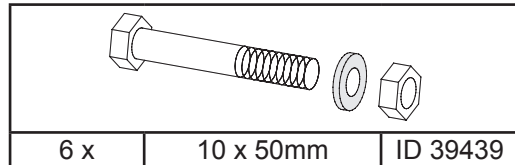
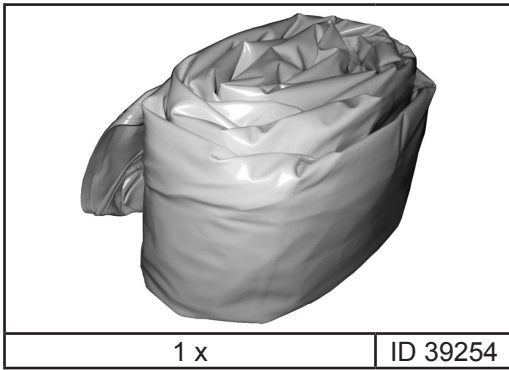
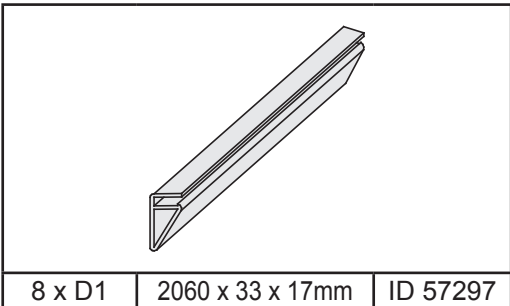

01

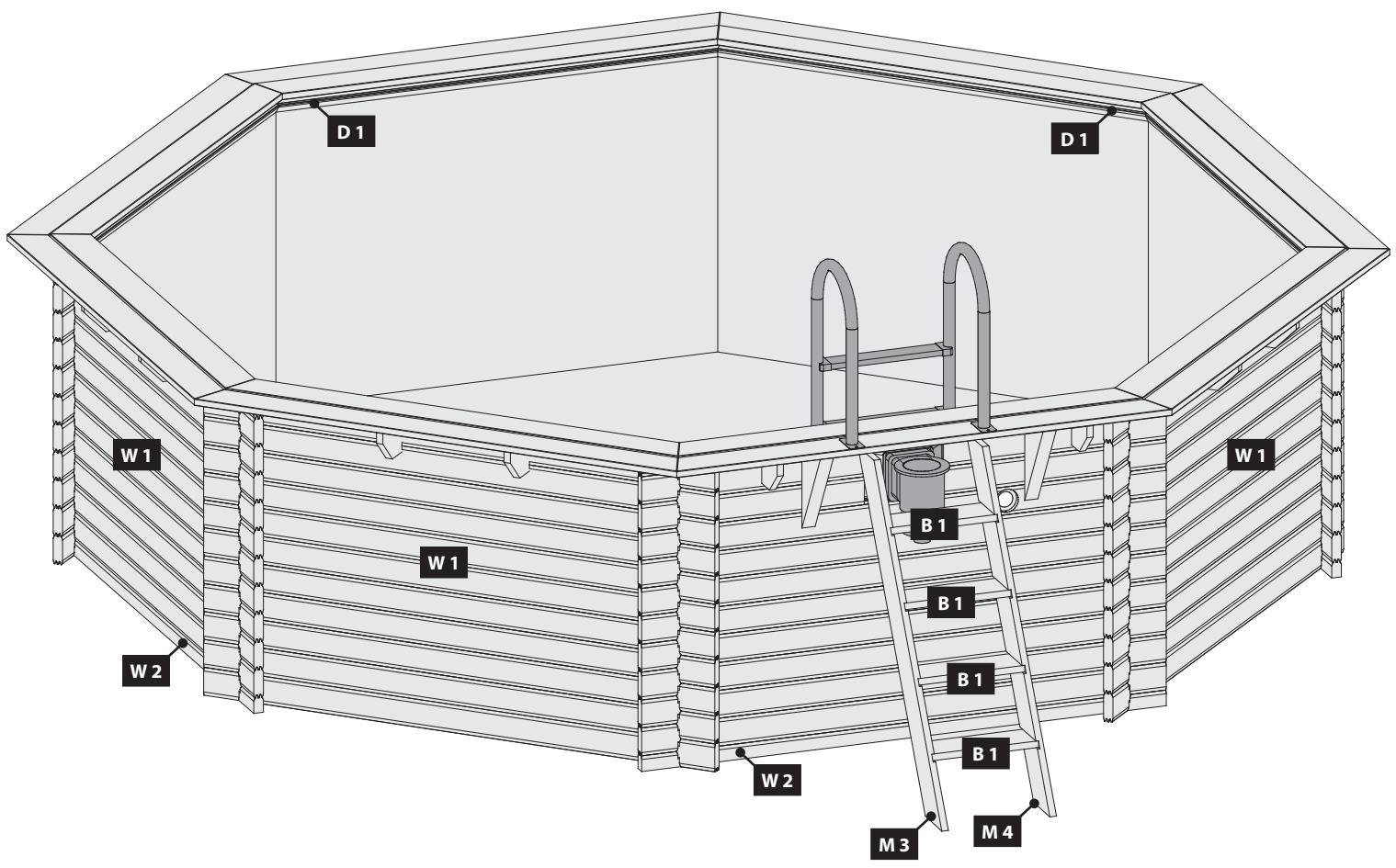

02

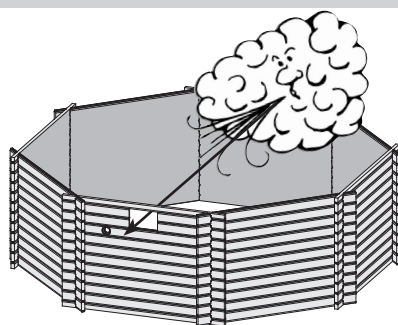

!!! A=B=C=D !!!

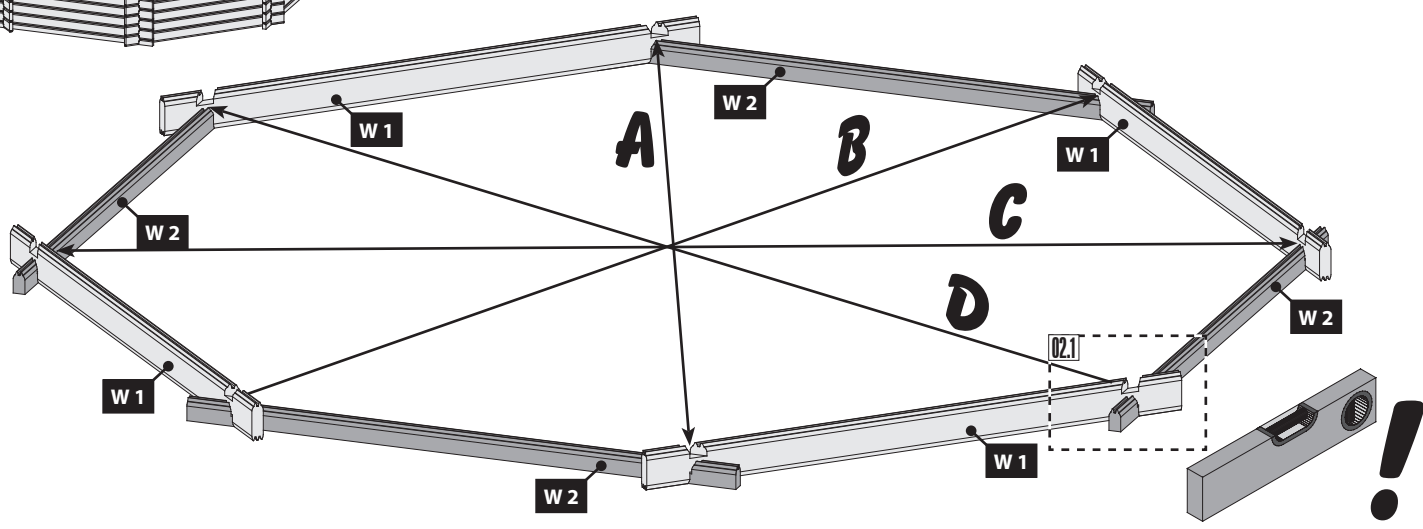

02.1-1

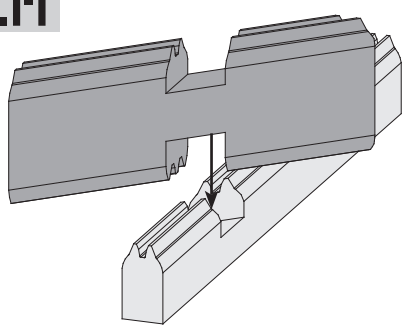

02.1-2

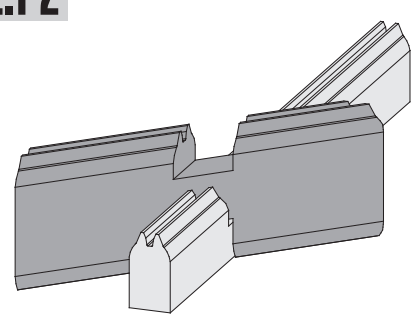

02.1-3

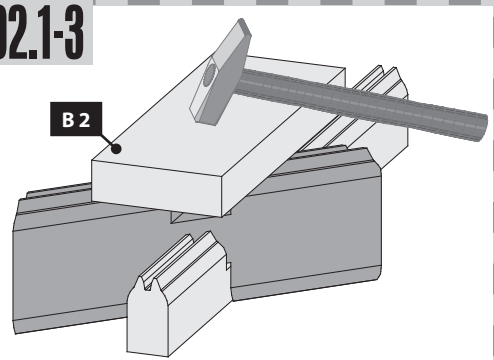

03

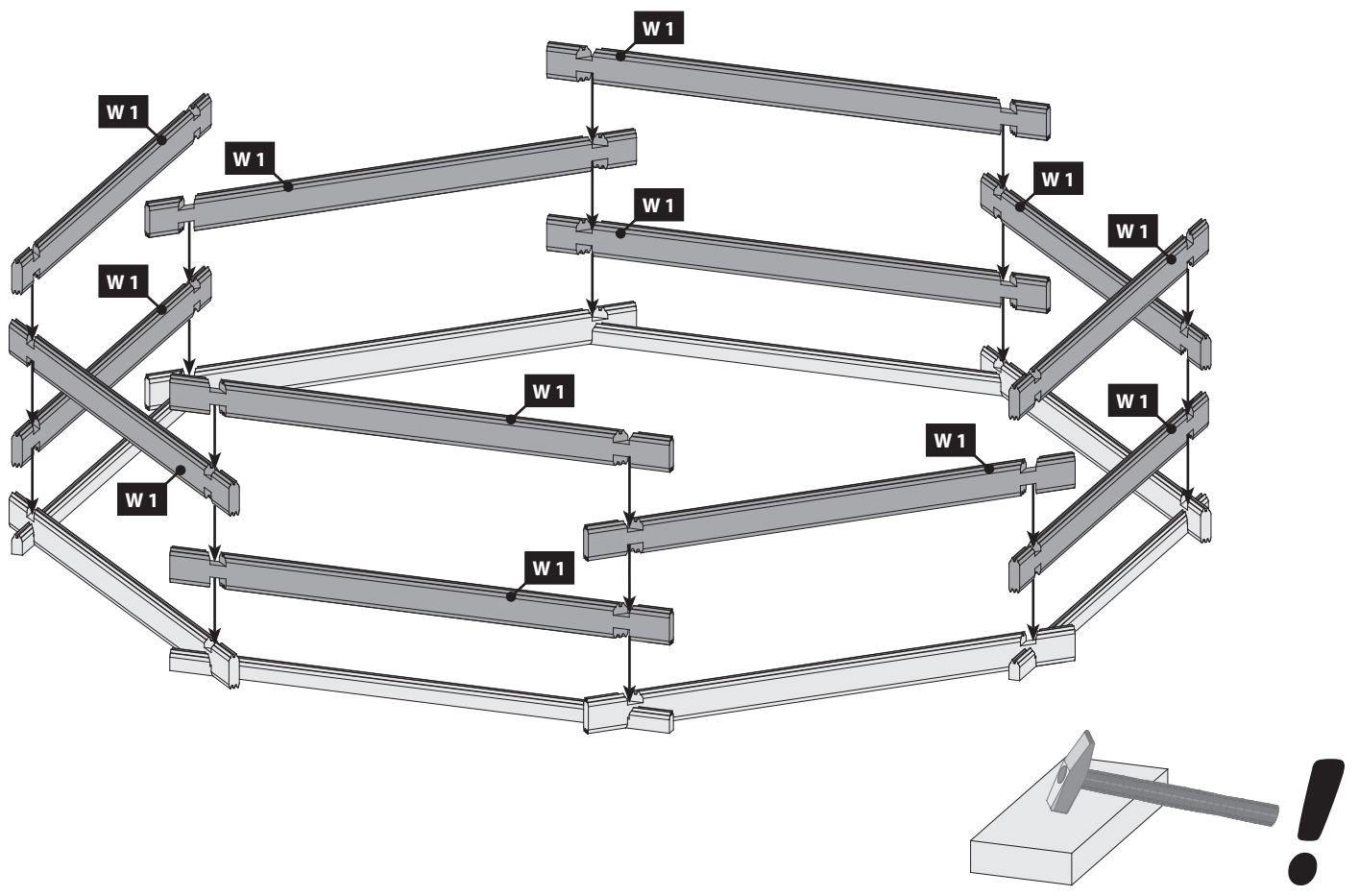

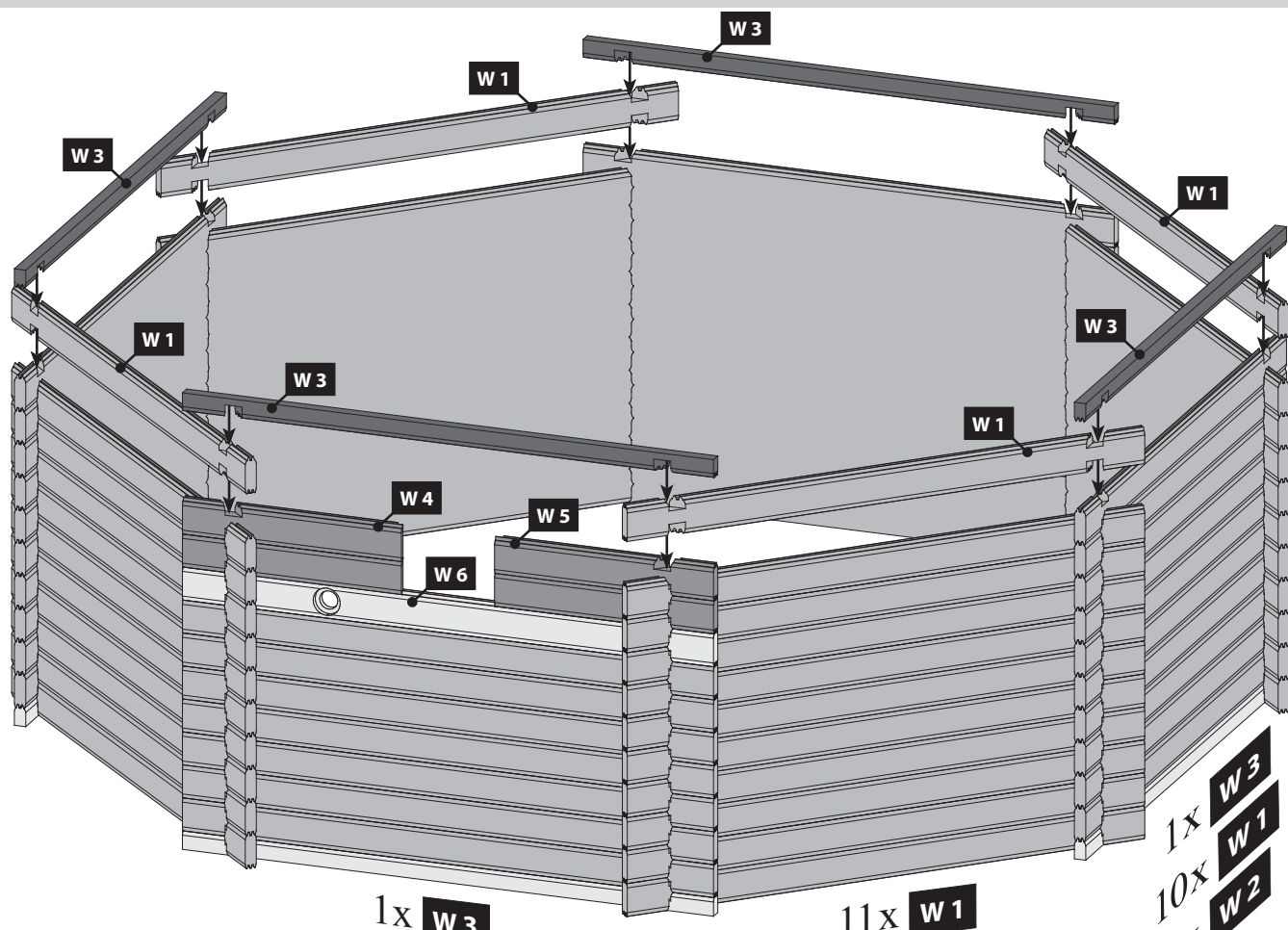

- 1x W3
- 2x W4
- 1x W6
- 7x W3
- 1x W2
- 2x W5
- 11x W1

- 1x W3
- 10x W1
- 1x W2

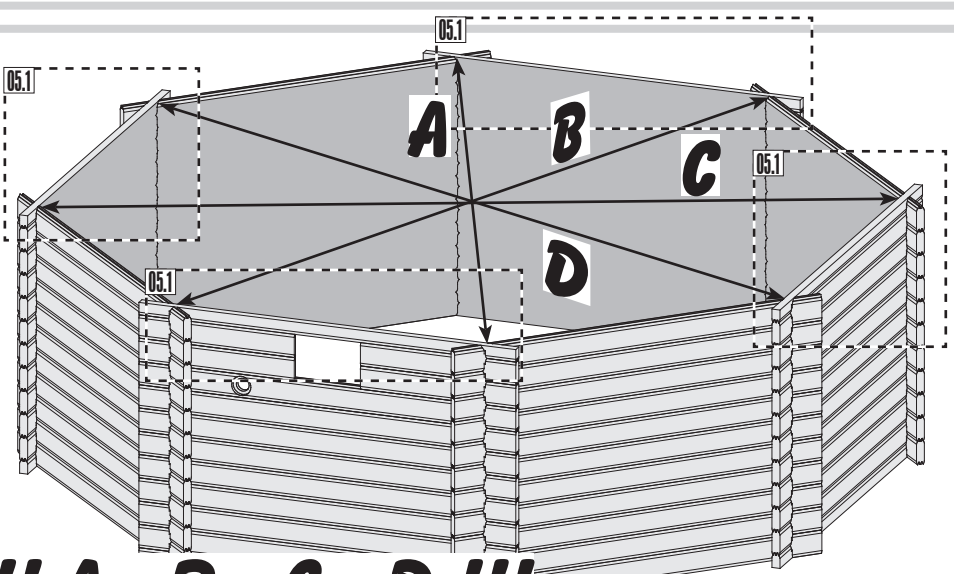
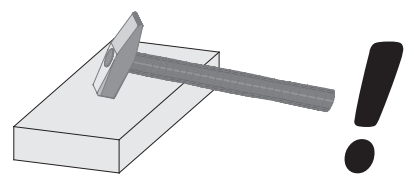

!!! A=B=C=D !!!

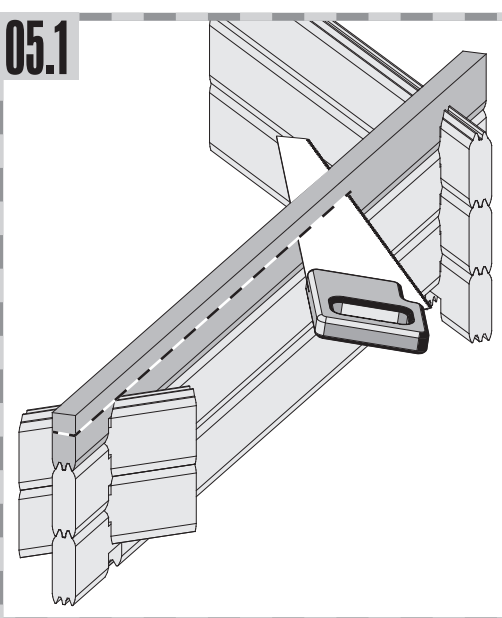

06

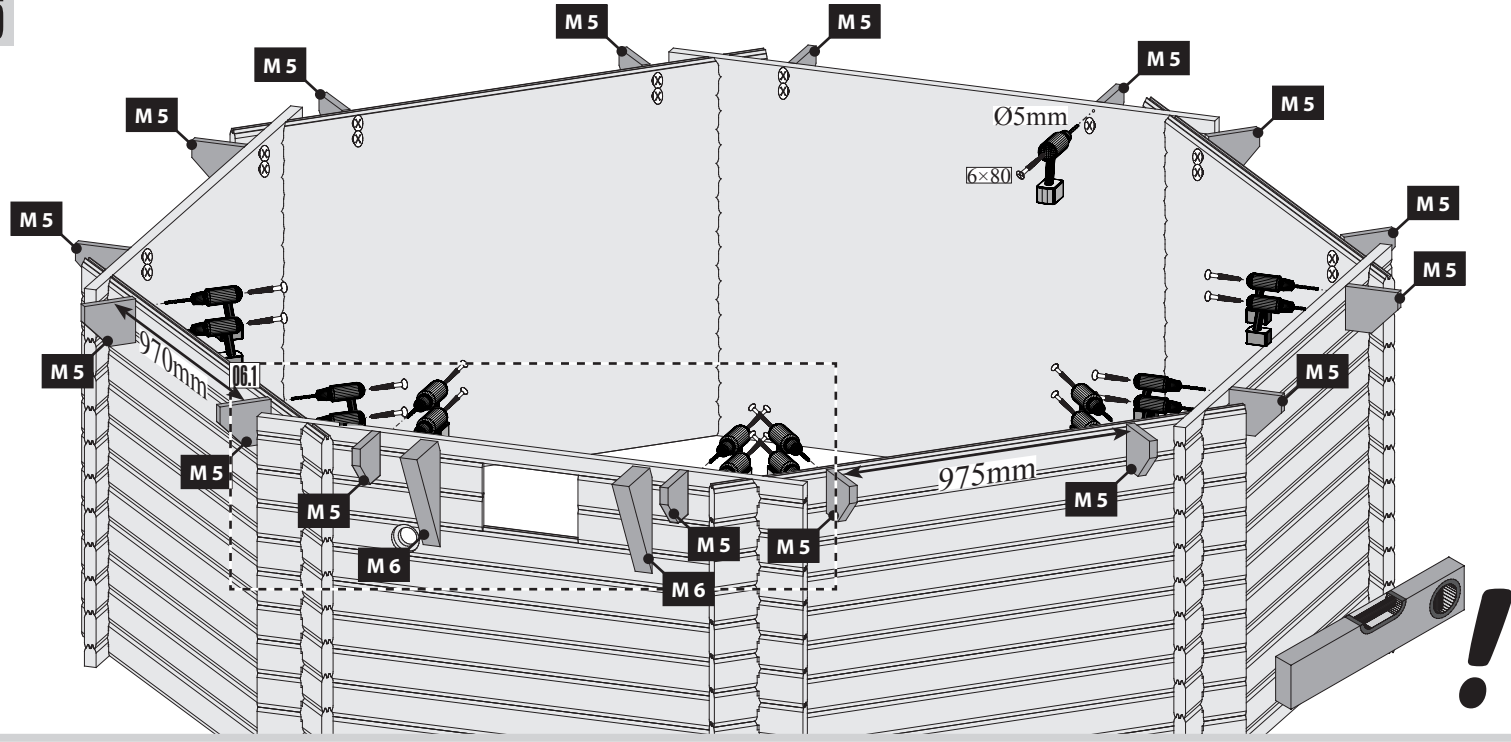

06.1

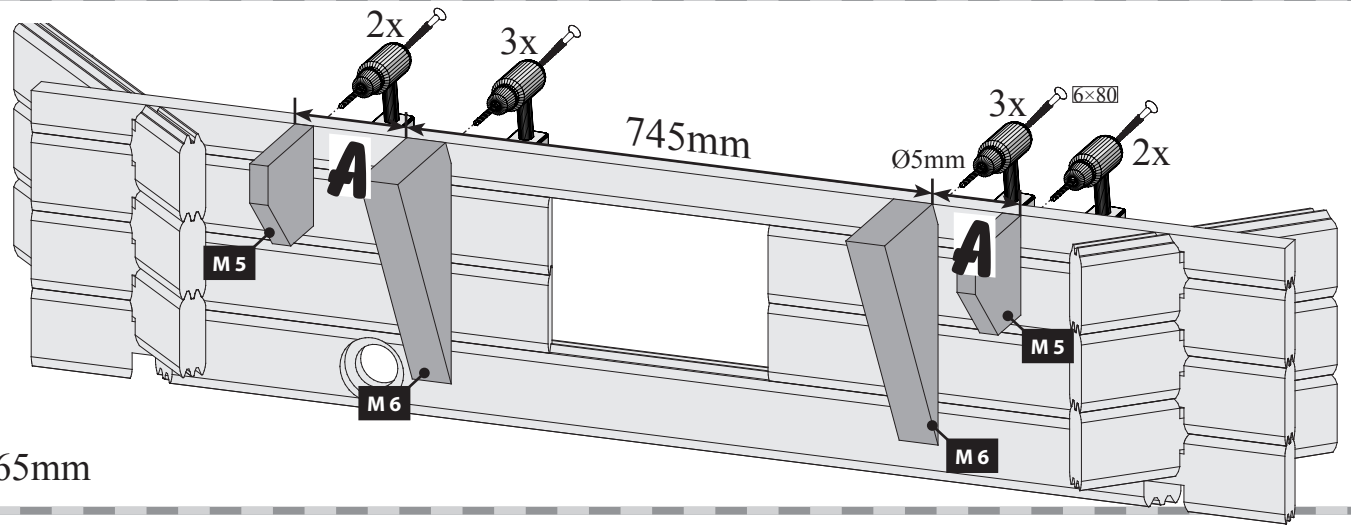

A=165mm

07

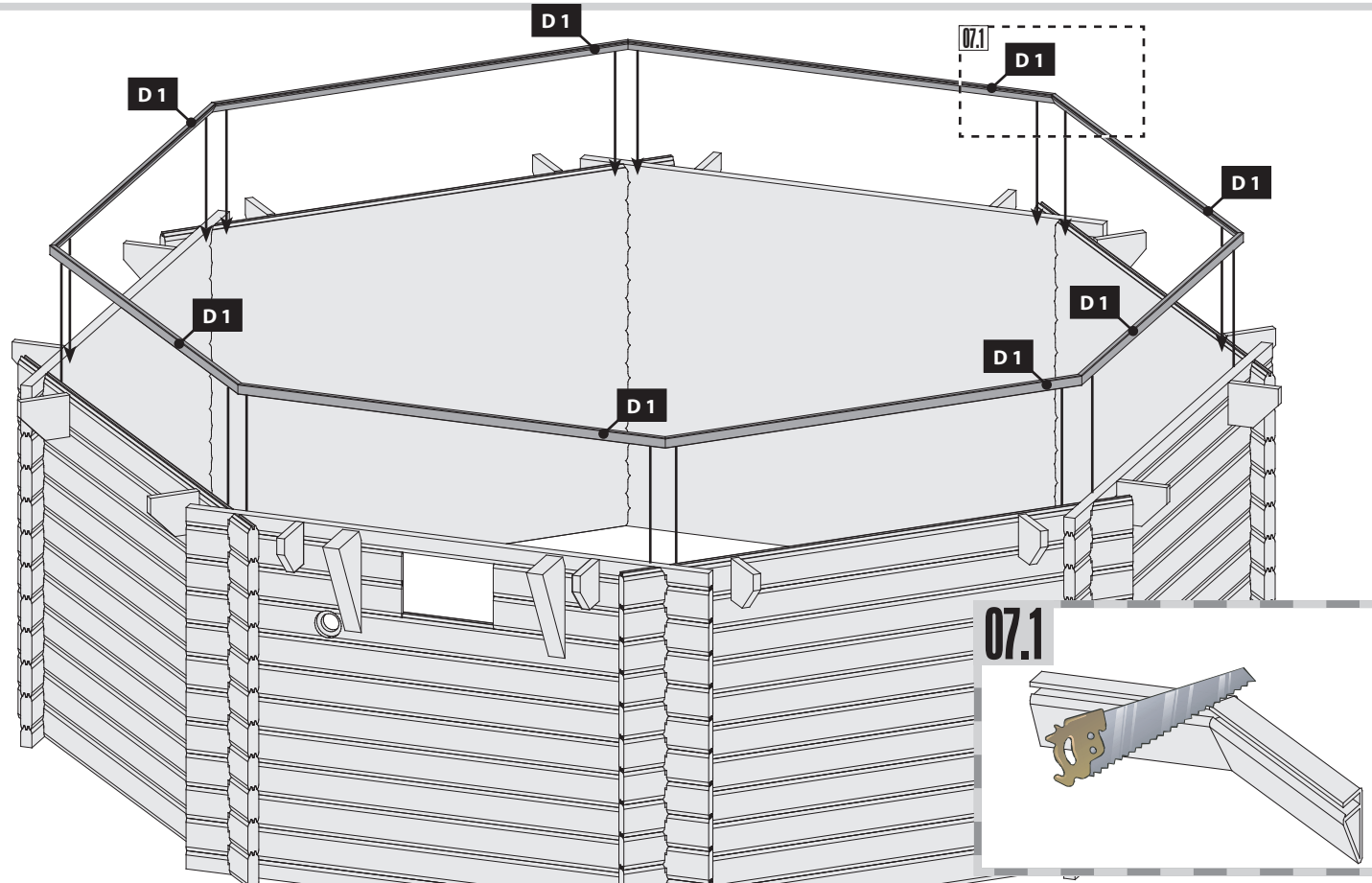

07.1

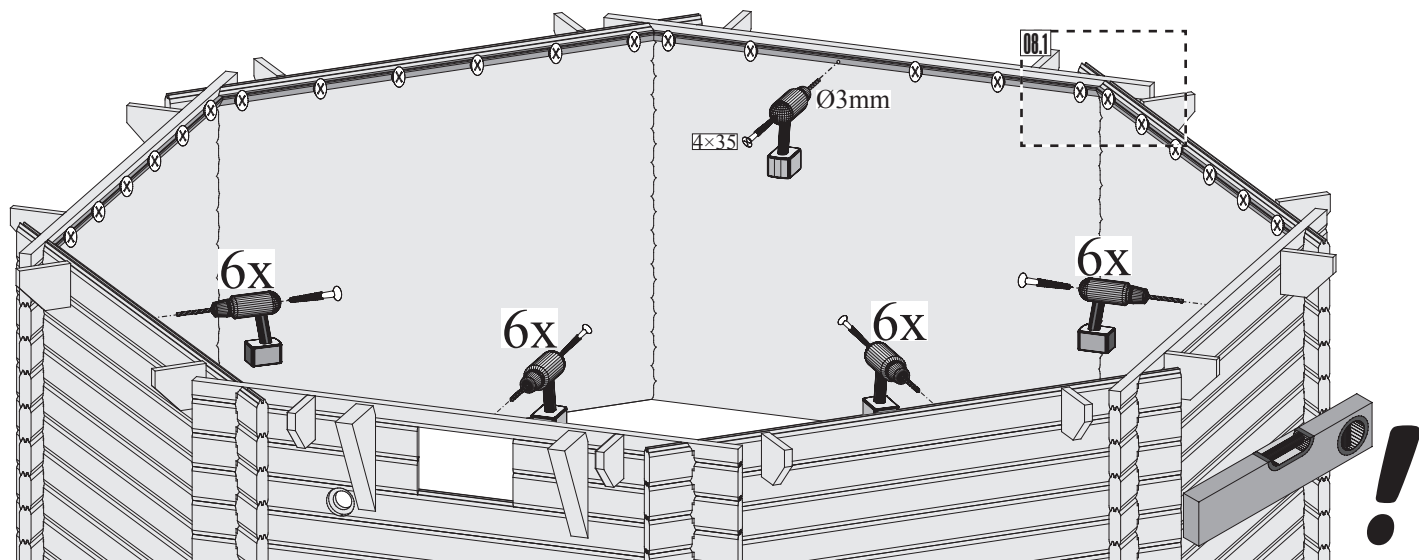

08.1

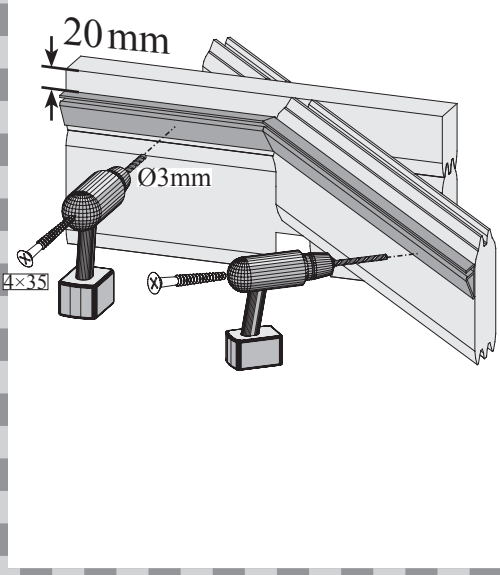

09

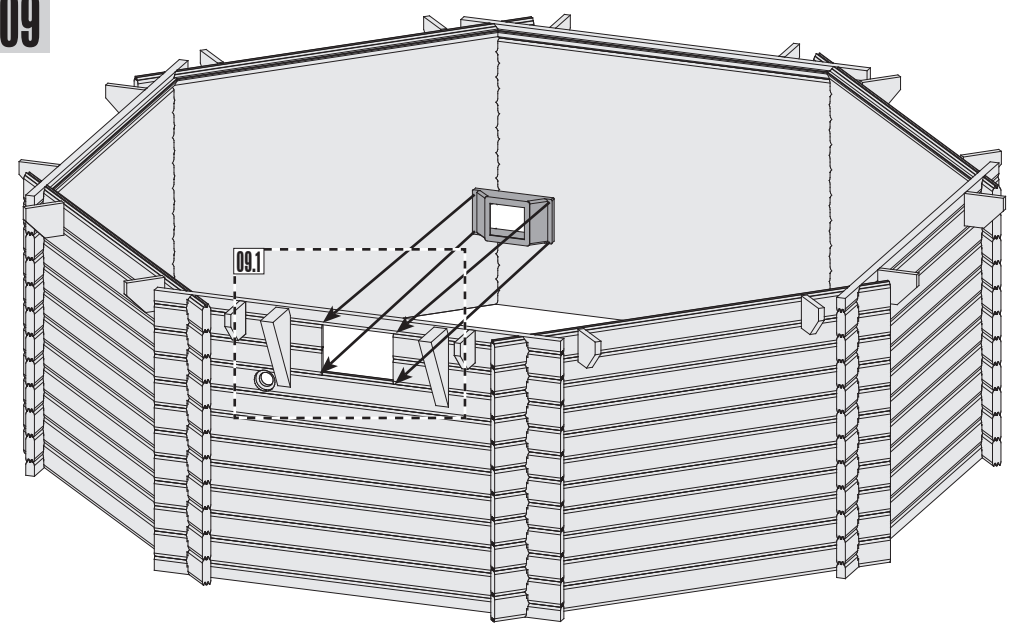

09.1-1

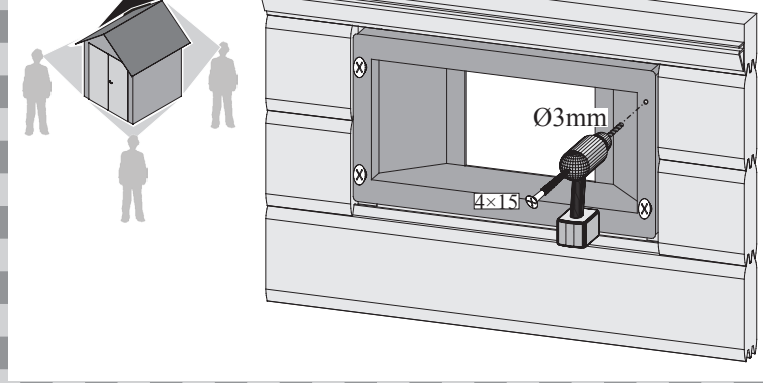

09.1-2

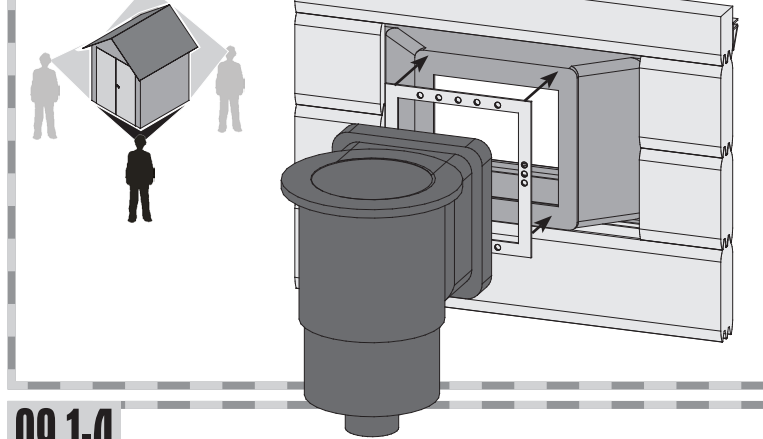

09.1-3

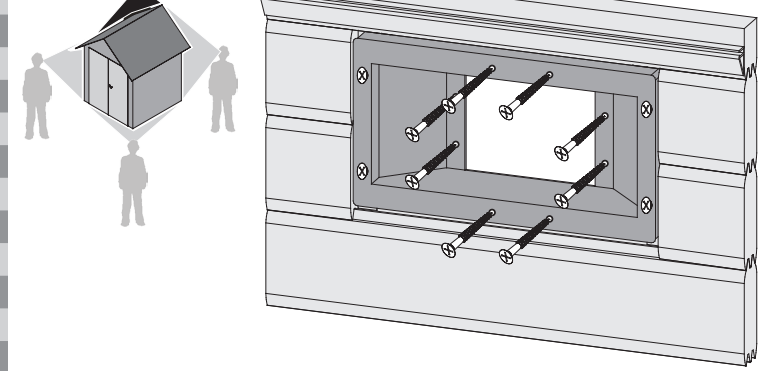

09.1-4

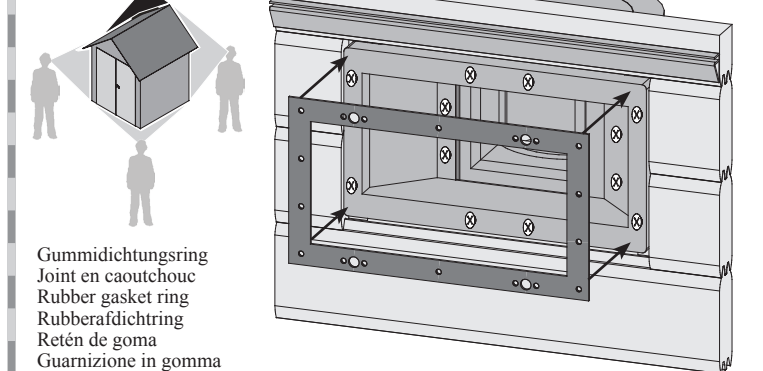

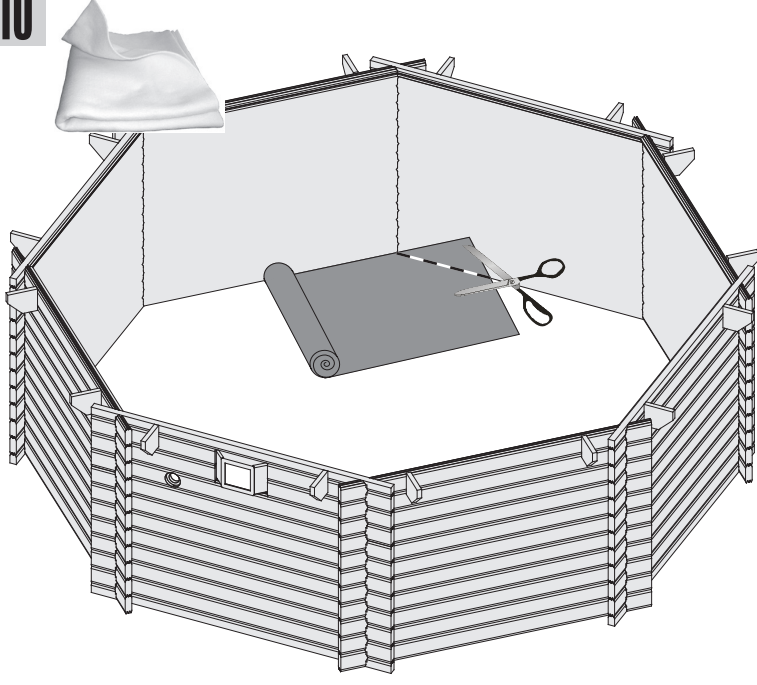
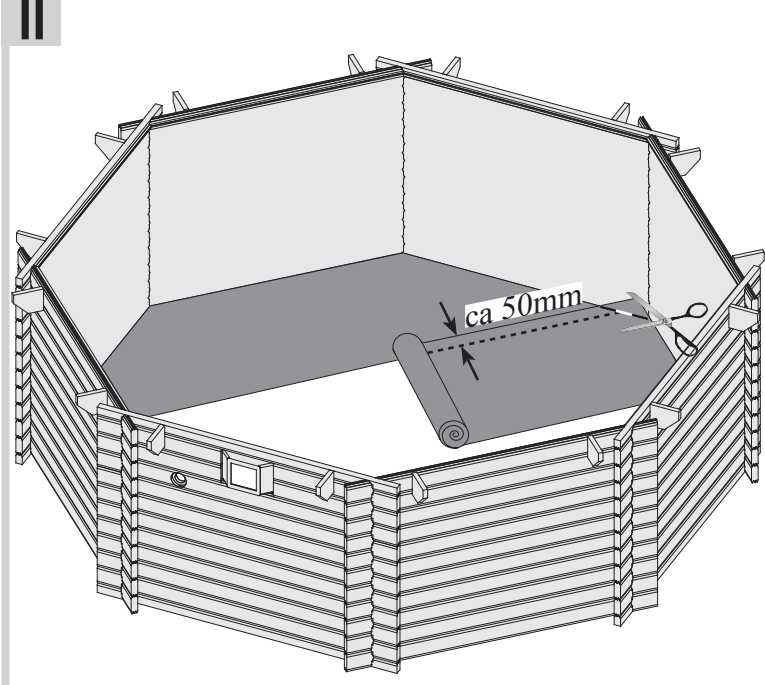
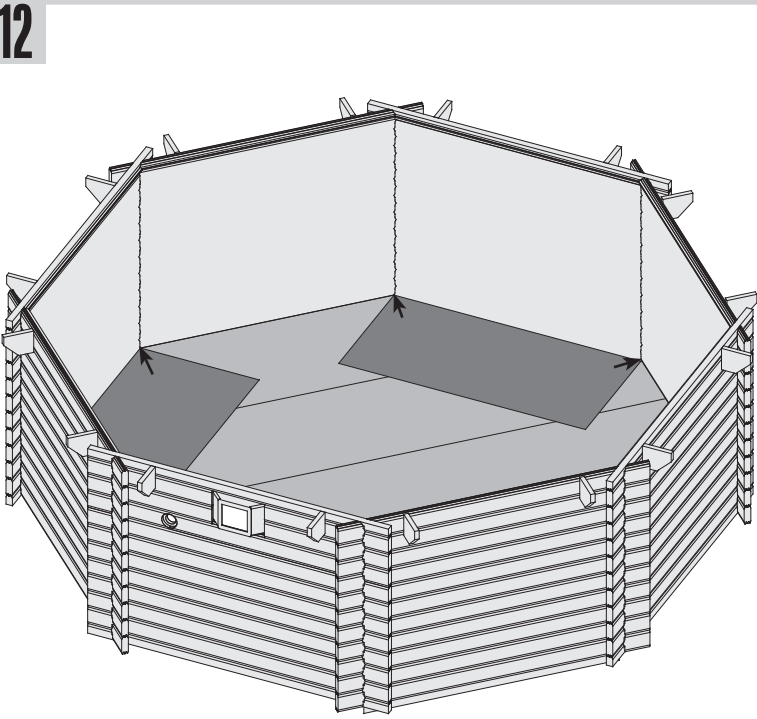
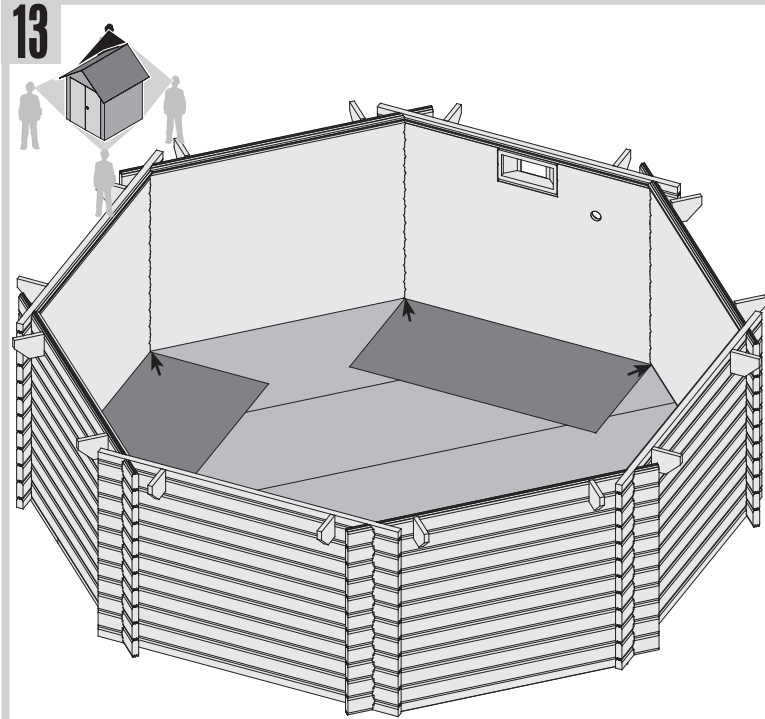
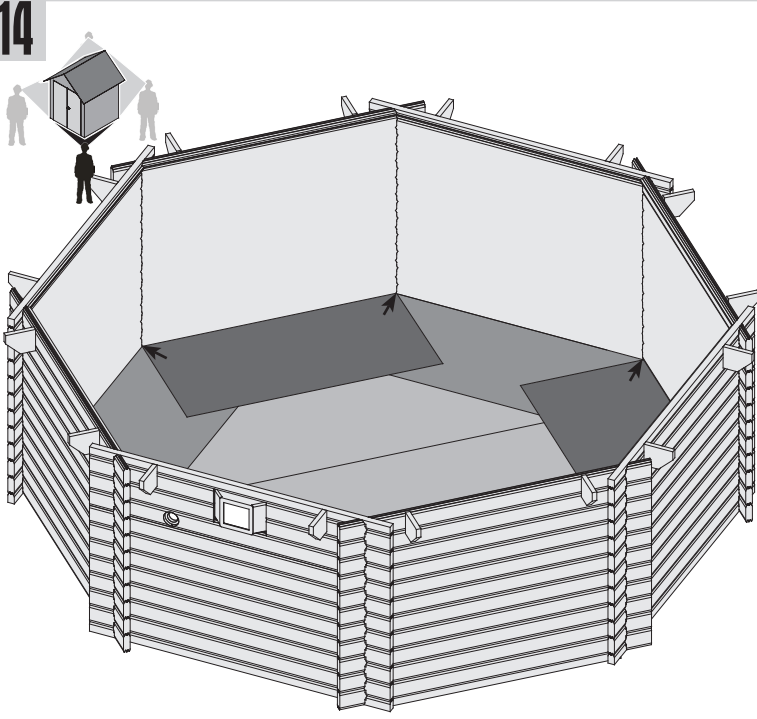
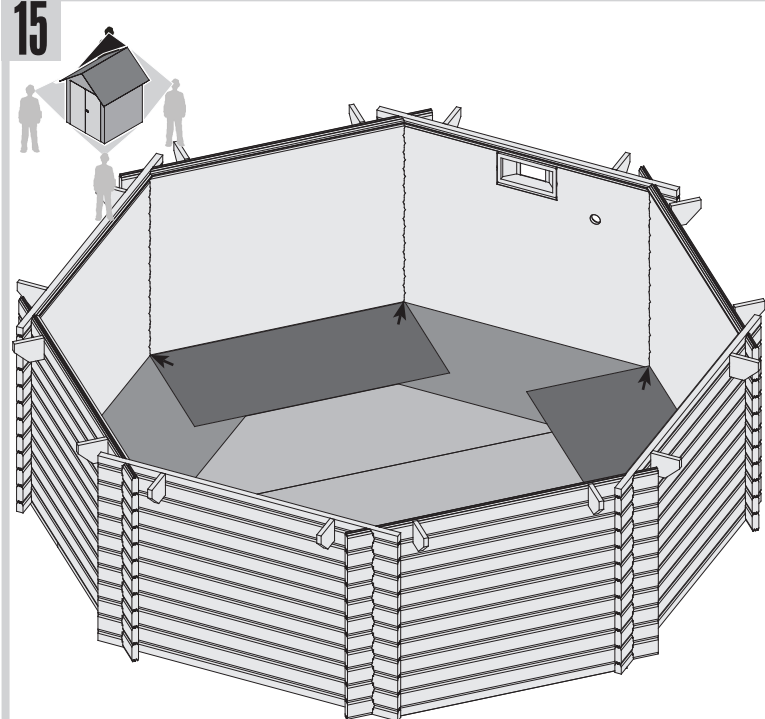
10**11****12****13****14****15**

16

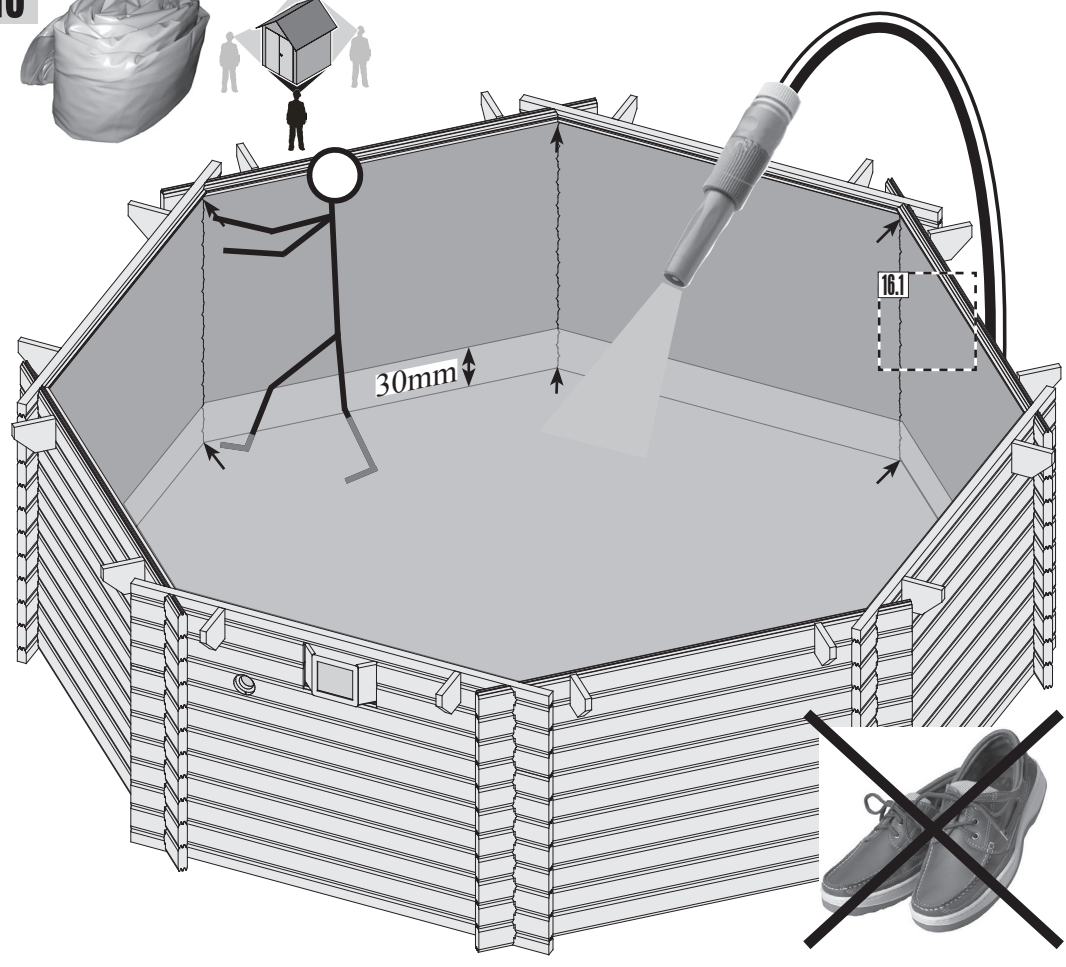
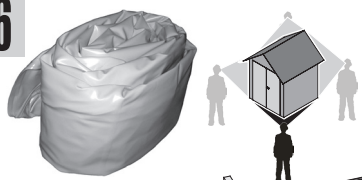

16.1-1

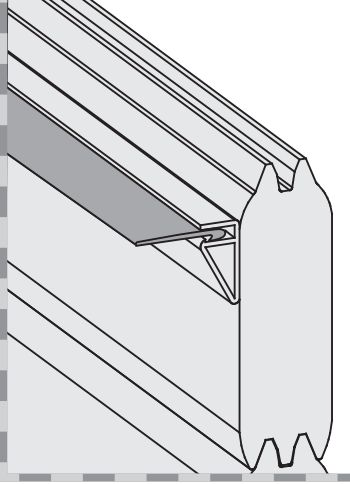

16.1-2

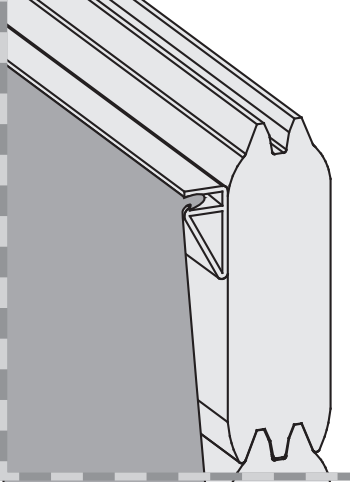

17

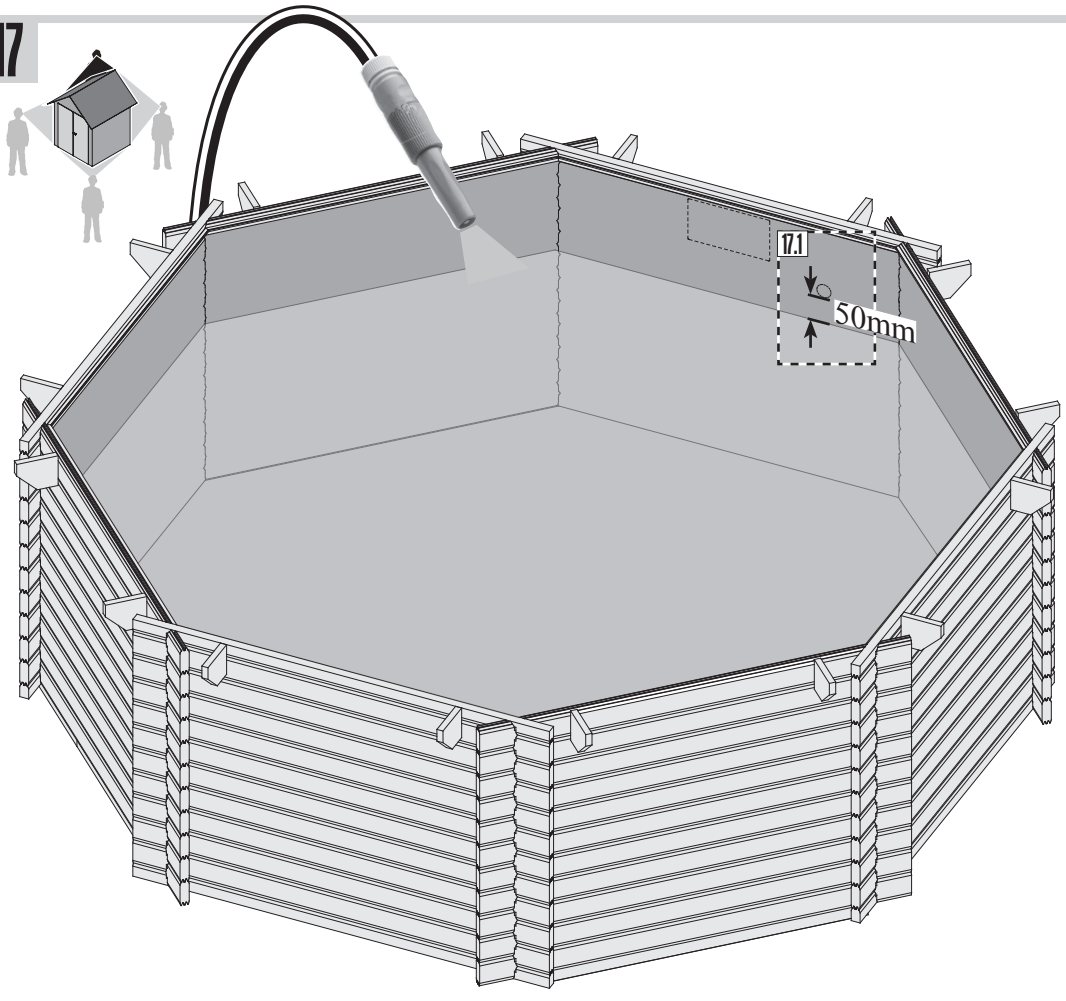
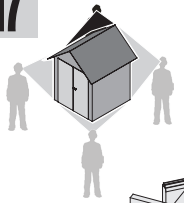

17.1-2

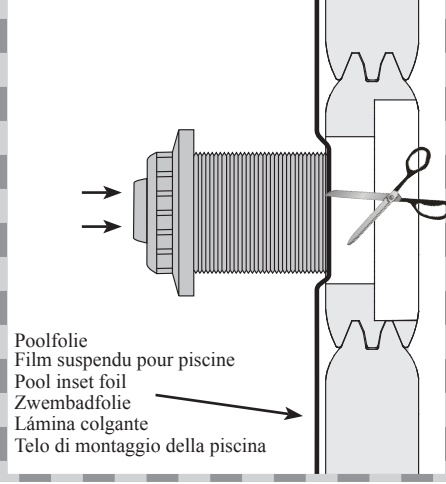

Poolfolie
 Film suspendu pour piscine
 Pool inset foil
 Zwembadfolie
 Lámina colgante
 Telo di montaggio della piscina

17.1-2

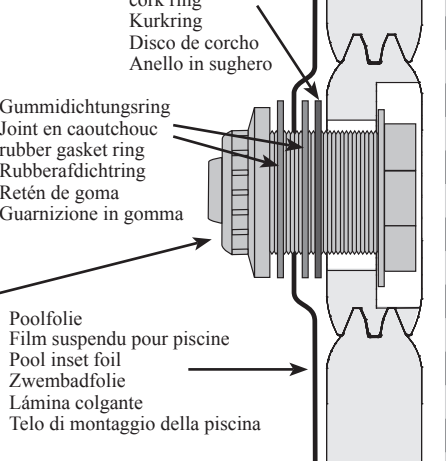

Korkring
 Anneau de liège
 cork ring
 Kurkring
 Disco de corcho
 Anello in sughero

Gummidichtungsring
 Joint en caoutchouc
 rubber gasket ring
 Rubberafdichtring
 Retén de goma
 Guarnizione in gomma

Einlaufdüse
 Tuyère d'alimentation
 inlet nozzle
 Zwembadfolie
 Tobera de entrada
 Bocchettone di afflusso

Poolfolie
 Film suspendu pour piscine
 Pool inset foil
 Zwembadfolie
 Lámina colgante
 Telo di montaggio della piscina

 **Zuschnitt der Düse**

 **Recorte para tobera**

 **Cutting the liner and fitting the backflow inlet nozzle**

 **Découpe buse**

 **Toglio per condotto**

 **Uitsnijden van instroomopening**

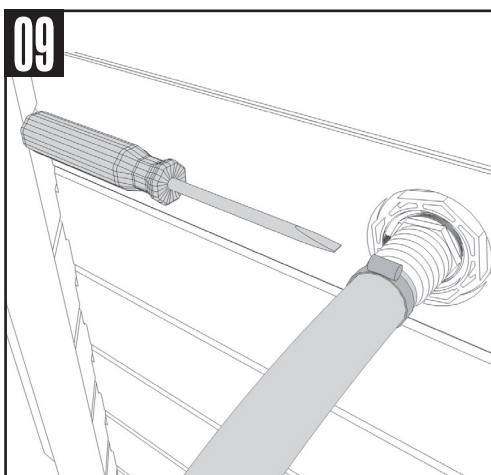
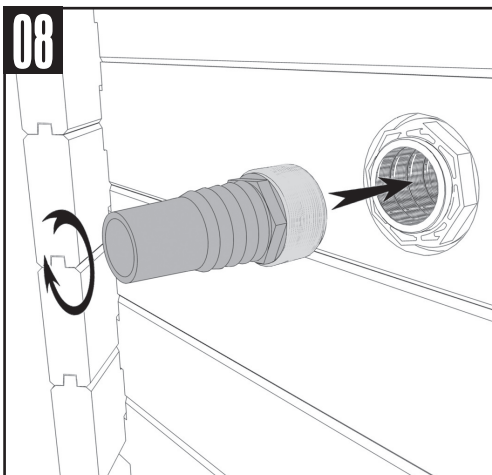
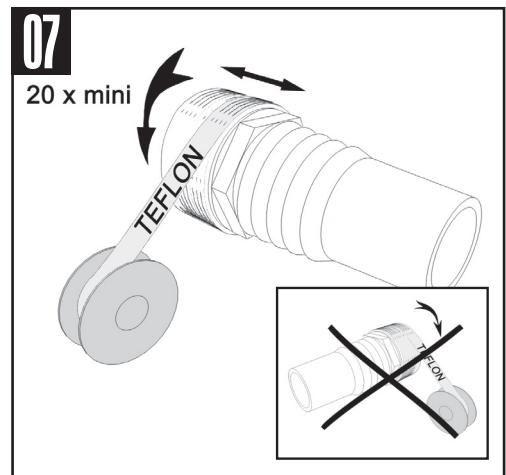
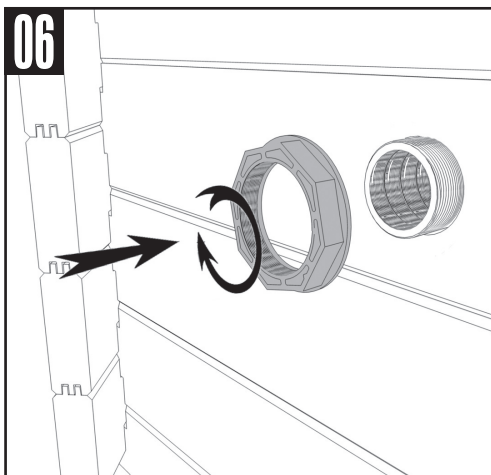
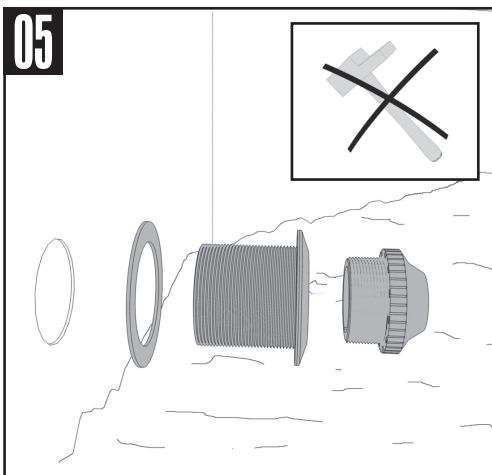
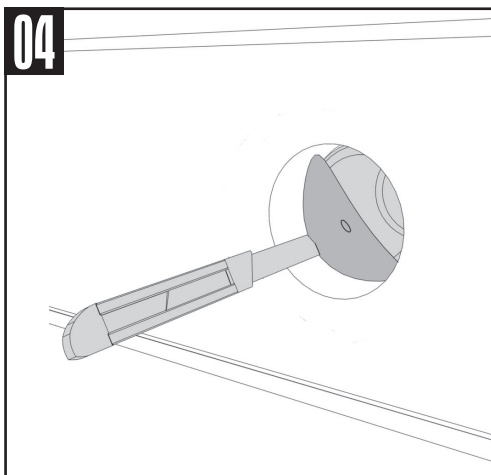
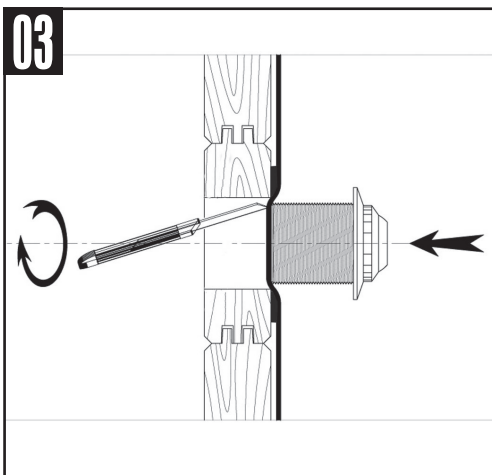
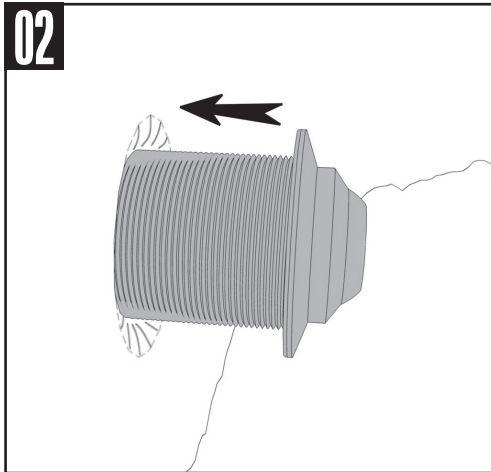
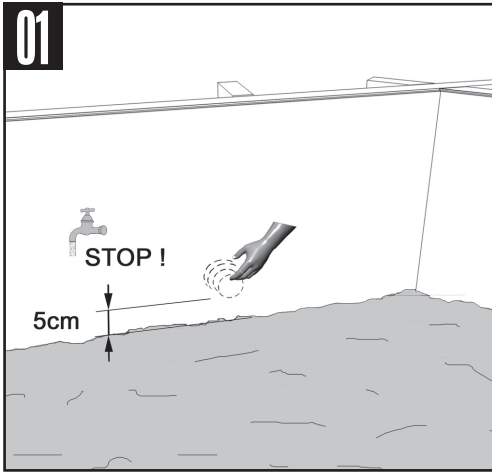

18

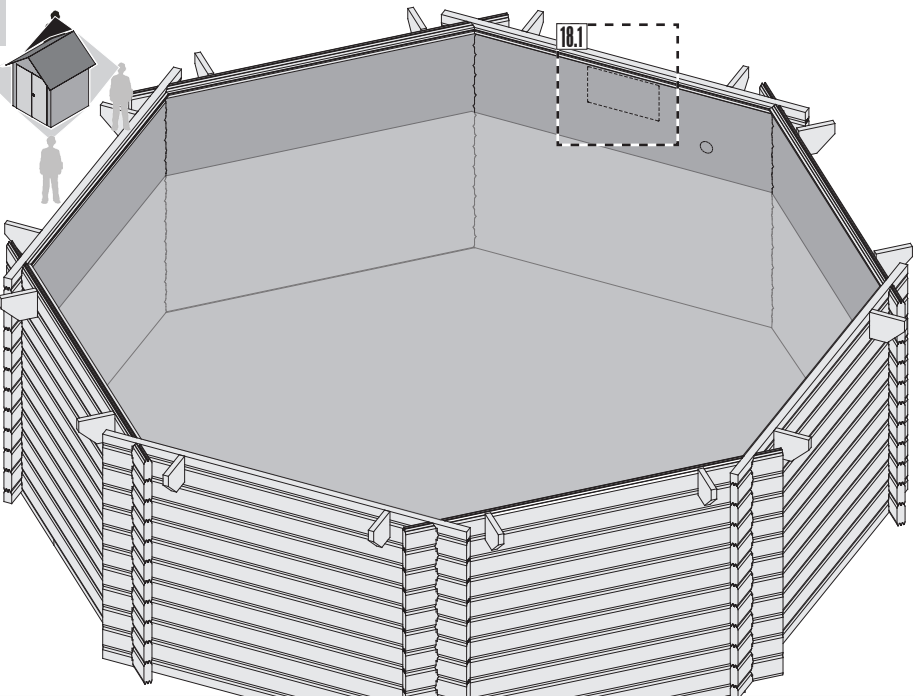

18.1-1

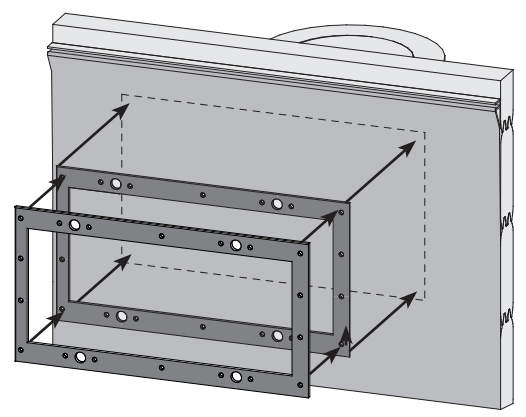

Gummidichtungsring
 Joint en caoutchouc
 Rubber gasket ring
 Rubberafdichting
 Retén de goma
 Guarnizione in gomma

18.1-2

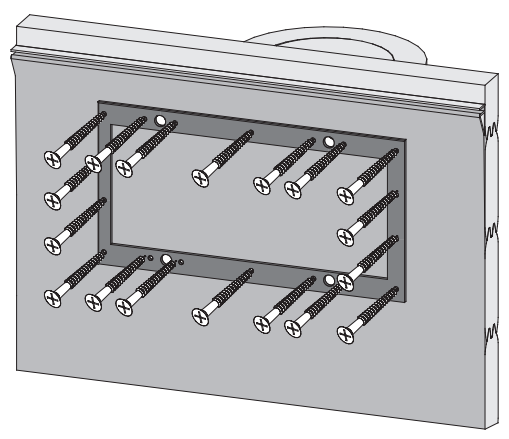

18.1-3

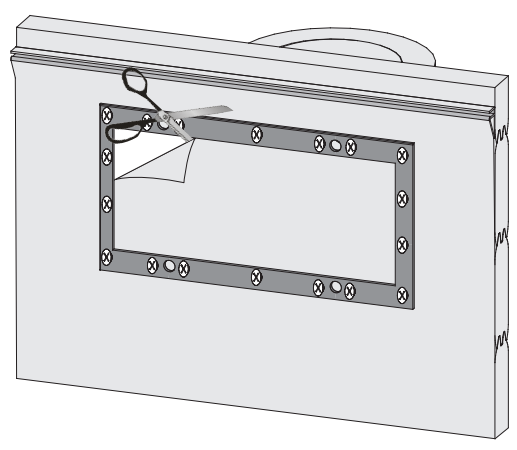

19

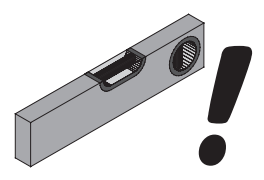
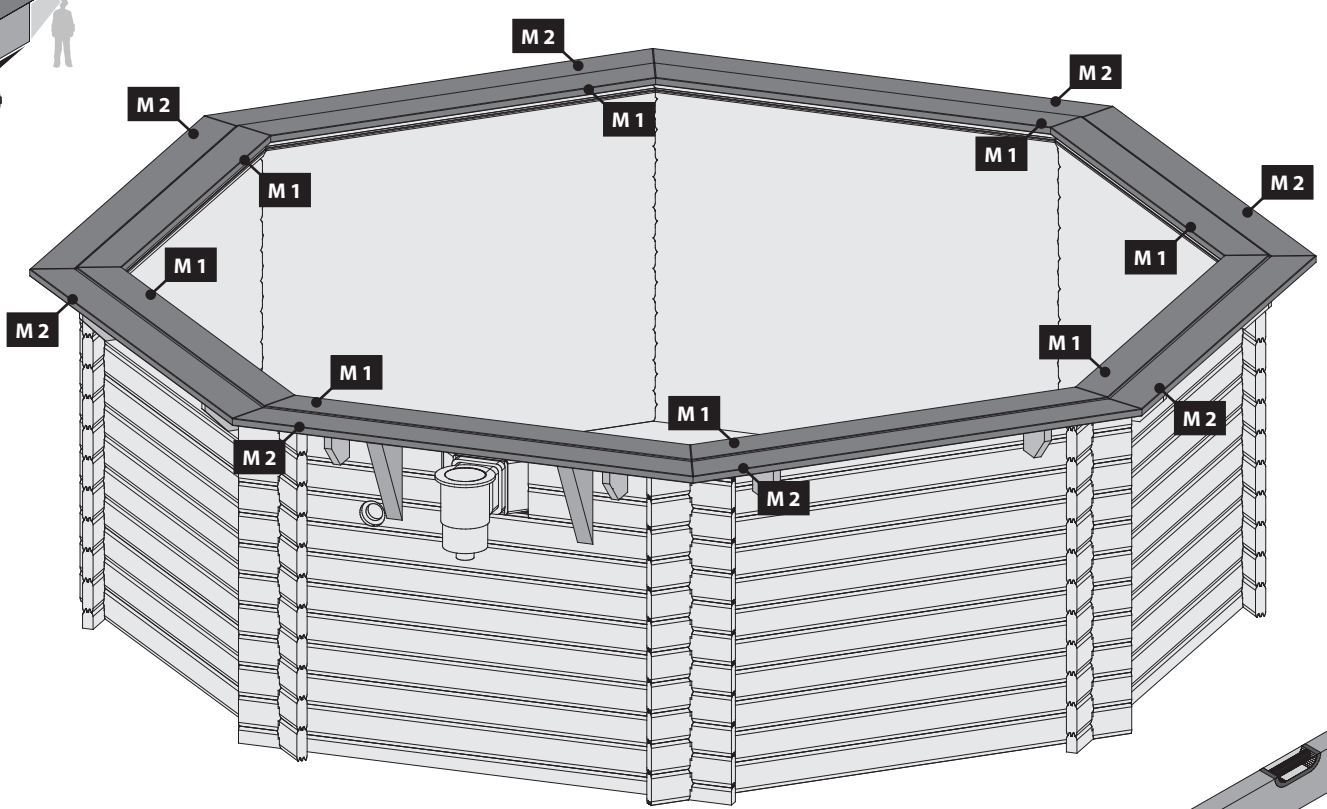
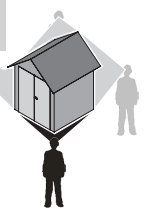

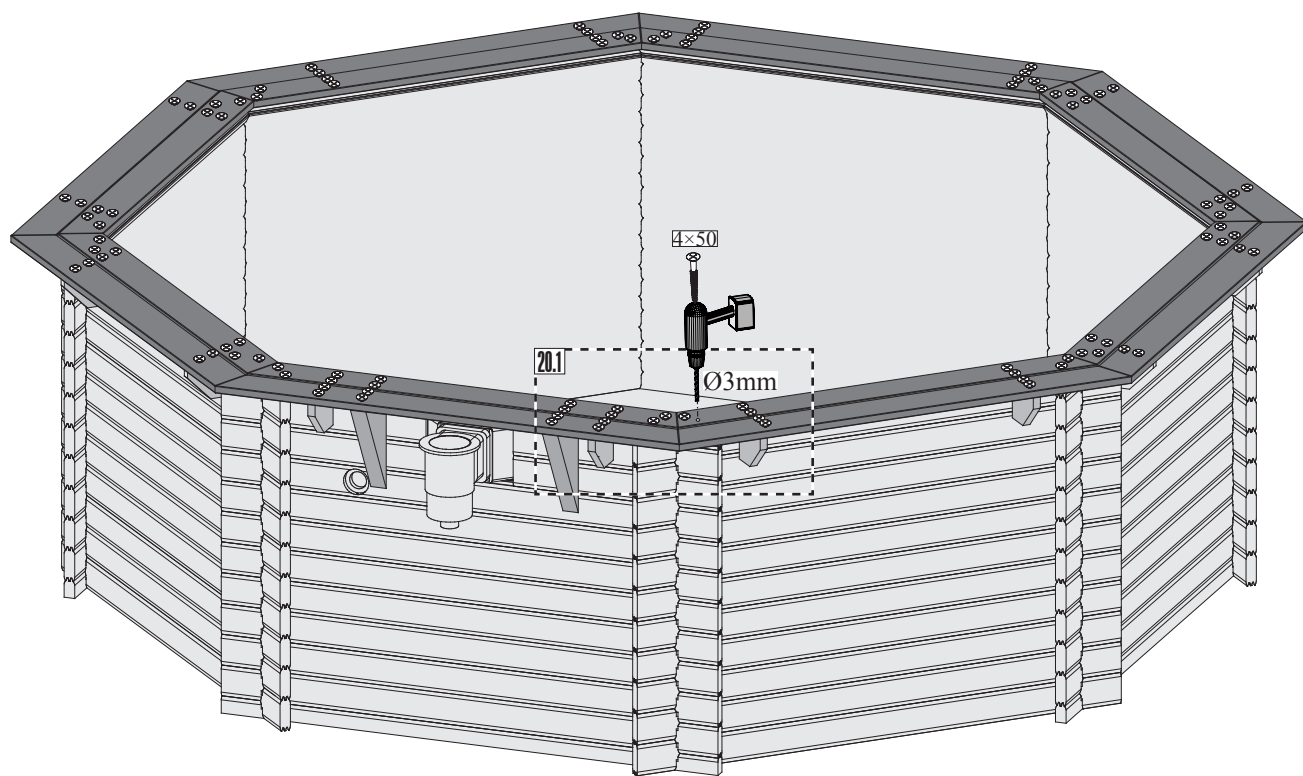

20.1-1

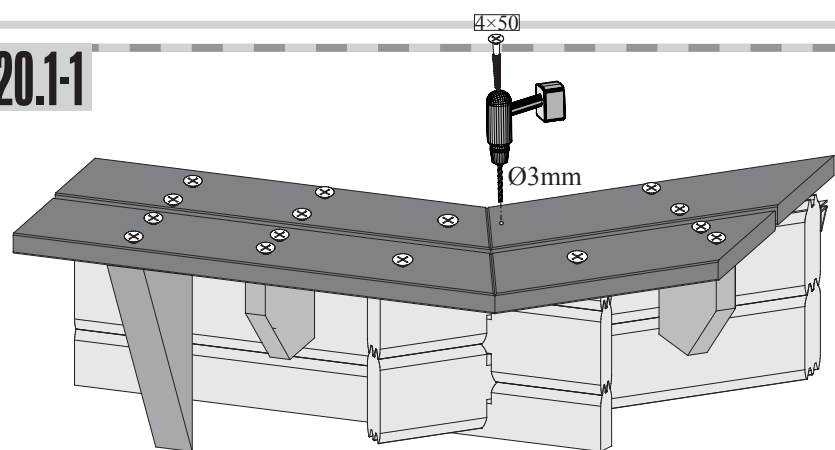

20.1-2

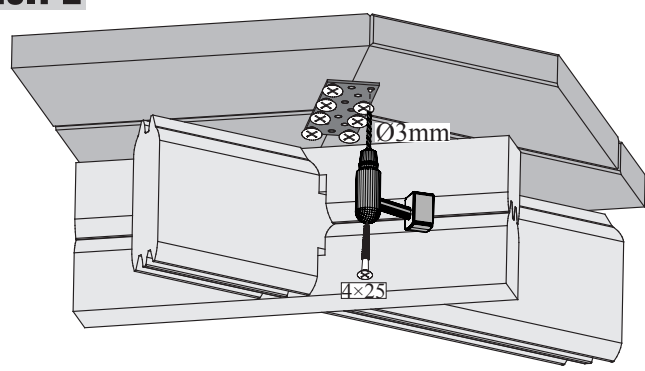

21

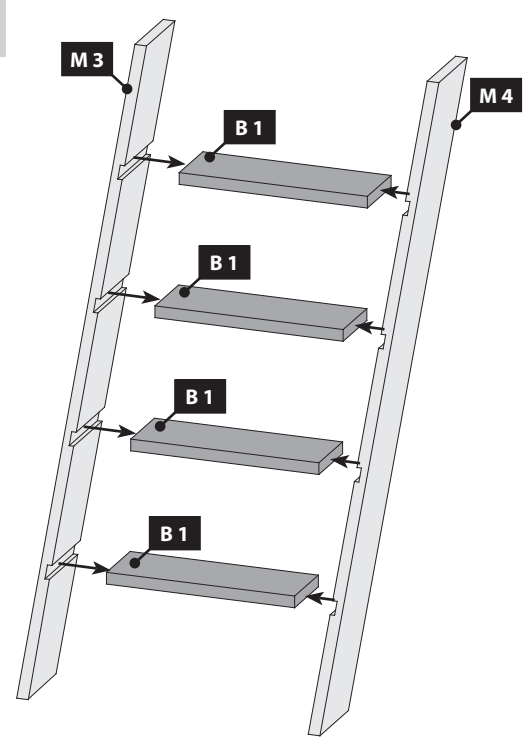

22

