

61593

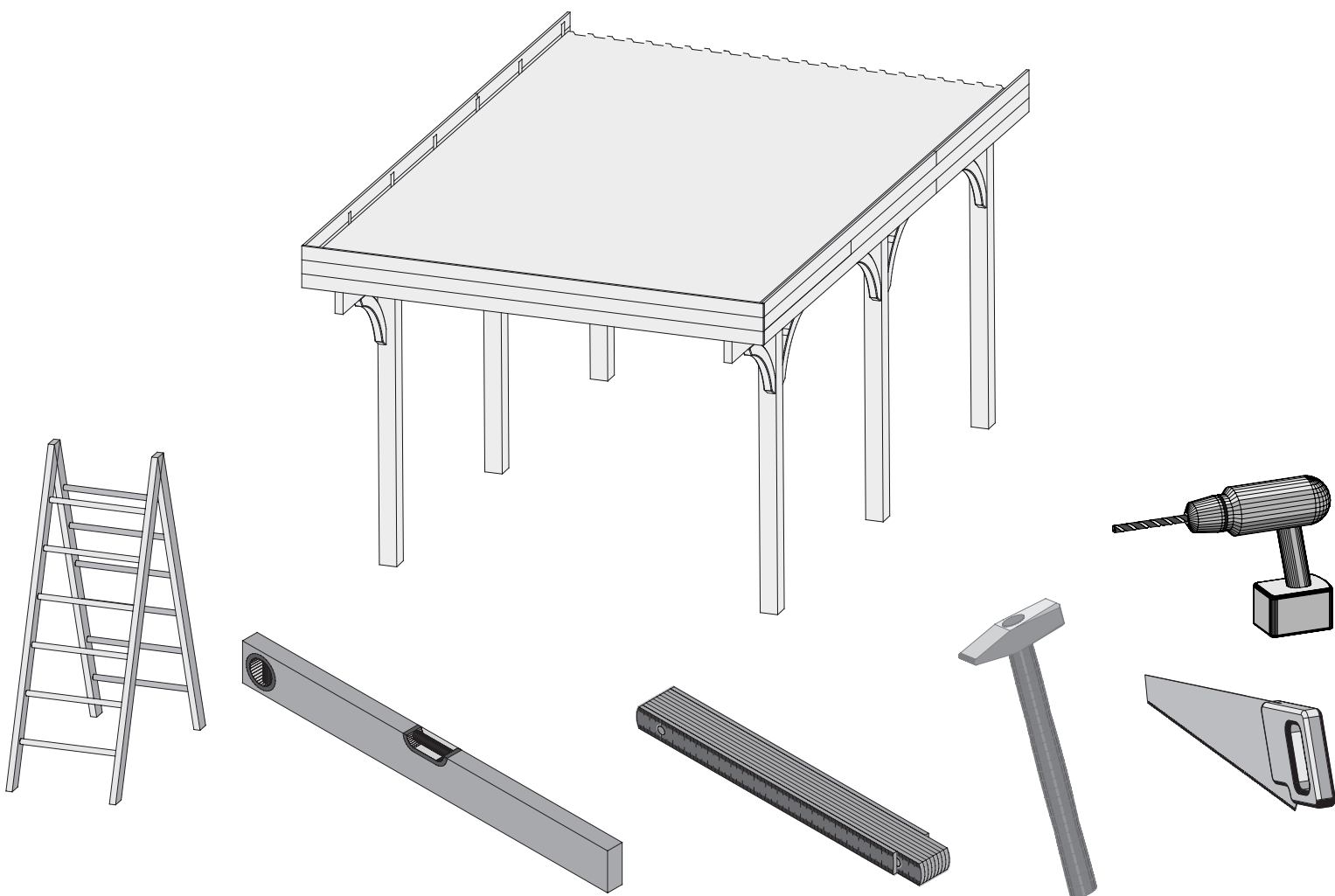

 **Aufbauanleitung**

 **notice de montage**

 **Building Instructions**

 **montagehandleiding**

 **Instrucciones de construcción**

 **Istruzioni per il montaggio**

 **Service-Hotline: +49 421 38693 33**

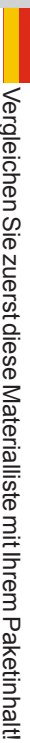
 Vergleichen Sie zuerst diese Materialliste mit Ihrem Paketinhalt! Bitte haben Sie Verständnis, daß Beanstandungen nur im nicht aufgebauten Zustand bearbeitet werden können!

 Vergelijk eerst deze materiaalijst met de inhoud van uw pakket. Wij vragen uw begrip voor het feit dat we klachten enkel in niet opgebouwde toestand kunnen behandelen.

 Veuillez d'abord comparer la liste du matériel avec le contenu de votre paquet ! Nous vous remercions de bien vouloir comprendre que nous traitons uniquement les réclamations concernant le matériel à l'état non monté !

 ¡En primer lugar compare la lista de material con el contenido de su paquete! ¡Rogamos entienda que las reclamaciones solo pueden ser tramitadas antes de montar el objeto!

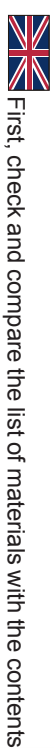
 First, check and compare the list of materials with the contents of your package! We ask for your understanding that complaints can only be processed when the product has not been assembled!

 Confrontate questa distinta materiali con il contenuto del pacchetto! Vi preghiamo di comprendere che eventuali reclami possono essere accolti solo prima del montaggio!

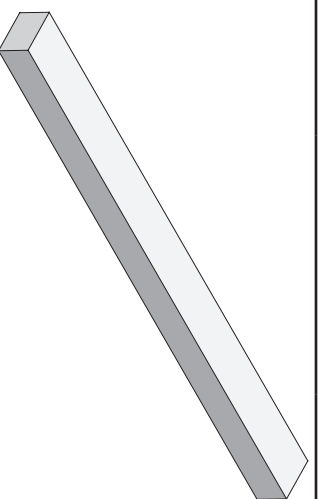

2 x B1	2100 x 95 x 18 mm	ID 52311
3 x B2	3300 x 95 x 18 mm	ID 51821

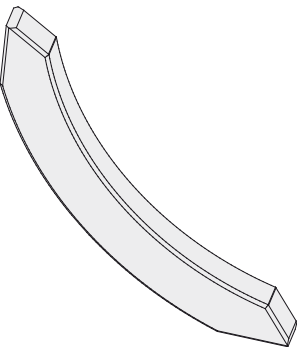

10 x U5	658 x 115 x 55 mm	ID 62616
---------	-------------------	----------

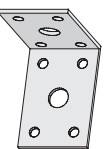

17 x S3	90 x 50 x 50 mm	ID 62872
---------	-----------------	----------

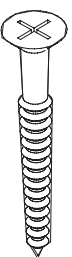

25 x	4 x 18 mm	ID 21191
200 x	4 x 50 mm	ID 3688
24 x	6 x 160 mm	ID 9252

 Dieses Produkt gibt es in verschiedenen Aufbauvarianten. Sie haben 1-5 Pakete erhalten. Die Stückzahl- und Materialkontrolle sollte immer mit der dem Paket beigefügten Materialliste durchgeführt werden.

Folgender Tabelle können Sie entnehmen, welche Anleitungsschritte mit welcher Nummer Sie zum Aufbau benutzen müssen. Orientieren Sie sich an der Anzahl der gelieferten Pakete und den Artikelnummern auf den Paketen.

 Dit product is er in verschillende opbouwvarianten. U hebt 1-5 pakketten ontvangen. Het aantal stuks en de materiaalcontrolle moet altijd met de bij het pakket gevoegde materiaallijst worden uitgevoerd.

In de volgende tabel kunt u zien welke instructiestappen met welk nummer u voor het opbouwen moet volgen. Oriënteer u aan het aantal geleverde pakketten en aan de artikelnummers op de pakketten.

 Ce produit existe dans différentes variantes de montage. Vous avez reçu 1-5 paquets. Le contrôle du nombre de pièces et du matériel doit

toujours être effectué à l'aide de la liste du matériel jointe au paquet.

Le tableau suivant vous indique quelles étapes de la notice avec quel numéro vous devez utiliser pour le montage. Veuillez vous orienter sur le nombre de paquets livrés et sur les numéros d'articles figurant sur les paquets.

 Existen distintas variantes de combinaciones de construcción de este producto. Ha recibido de 1 a 5 paquetes. El control de la cantidad y del material siempre debería ser realizado con la lista del material adjunta al paquete.

En la tabla siguiente puede obtener la información del número que debe utilizar con cada etapa de las instrucciones para la construcción. Oriéntese mediante el número de paquetes suministrados y los números de artículos sobre estos.



 This product is available in different construction variants. You have received 1-5 packages. Always control the numbers and materials on the basis of the material list included with the package.



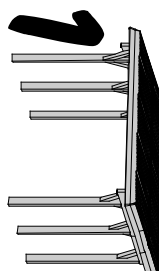

The following table shows which instruction corresponds to which number during assembly of the construction. Construction is oriented to the number of packages supplied and the article numbers shown on the packages.

 Questo prodotto è disponibile in diverse varianti. La consegna può consistere in un numero di pacchi che può variare da 1 a 5. Il controllo del nu-

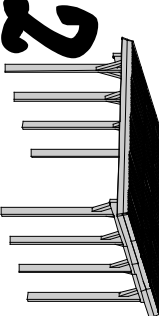
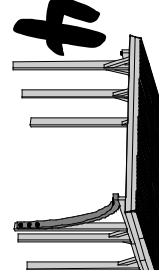
mero di pezzi e del materiale va eseguito sempre con la distinta dei materiali allegata al pacchetto.

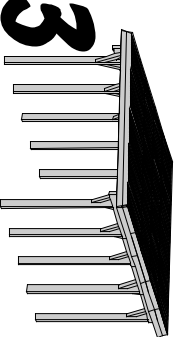
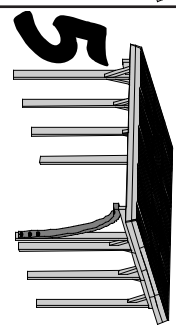
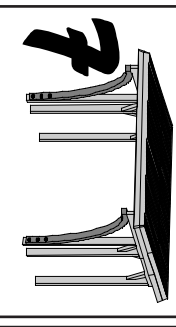
Dalla seguente tabella si può dedurre quali istruzioni per l'uso (indicate con i relativi codici) si devono utilizzare per il montaggio. Ci si può orientare basandosi sul numero di pacchetti consegnati e sul codice articolo riportato sui pacchetti stessi.

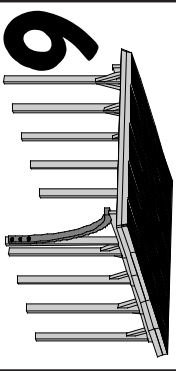
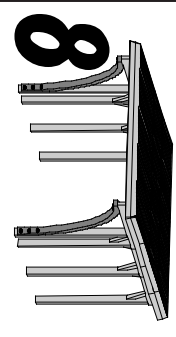
<p>1x</p>  <p>1x ID 61576</p> 	<p>2x</p>  <p>1x ID 61576 1x ID 61579</p>  <p>1x ID 61576 1x ID 45598</p> 
--	--

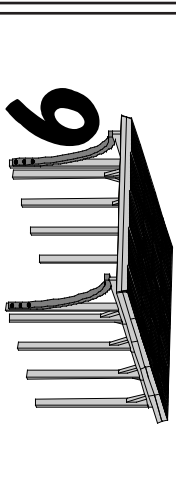
<p>3x</p>  <p>1x ID 61576 2x ID 61579</p> 	<p>1x ID 61576 1x ID 61579 1x ID 45598</p> 	<p>1x ID 61576 2x ID 45598</p> 
<p>4x</p>  <p>1x ID 61576 2x ID 61579 1x ID 45598</p> 	<p>1x ID 61576 1x ID 61579 2x ID 45598</p> 	<p>5x</p>  <p>1x ID 61576 2x ID 61579 2x ID 45598</p> 

1. 2x

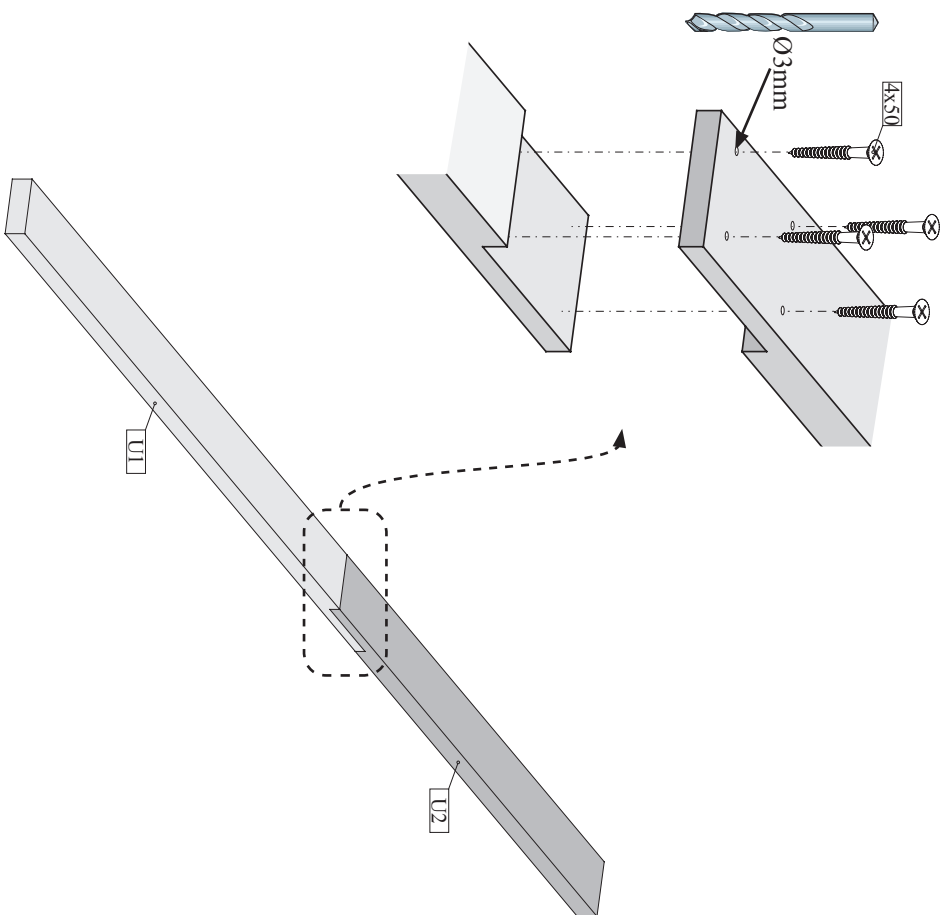
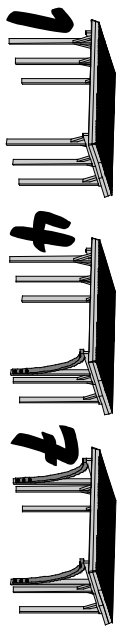

1. 2x

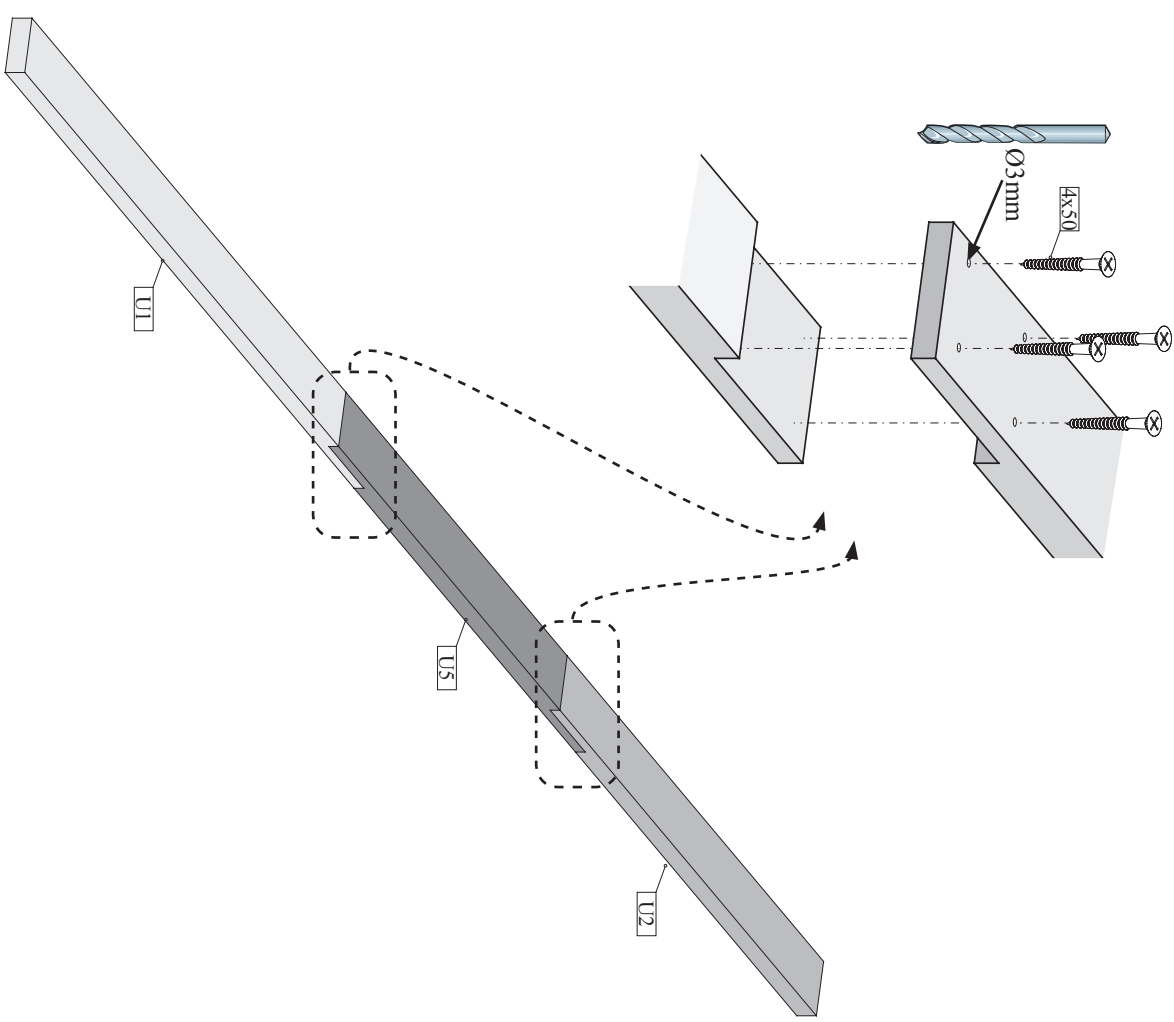
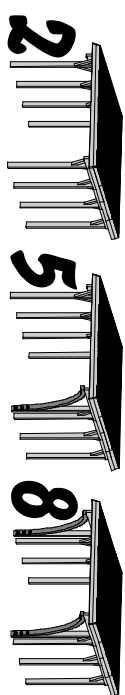

1. 2x

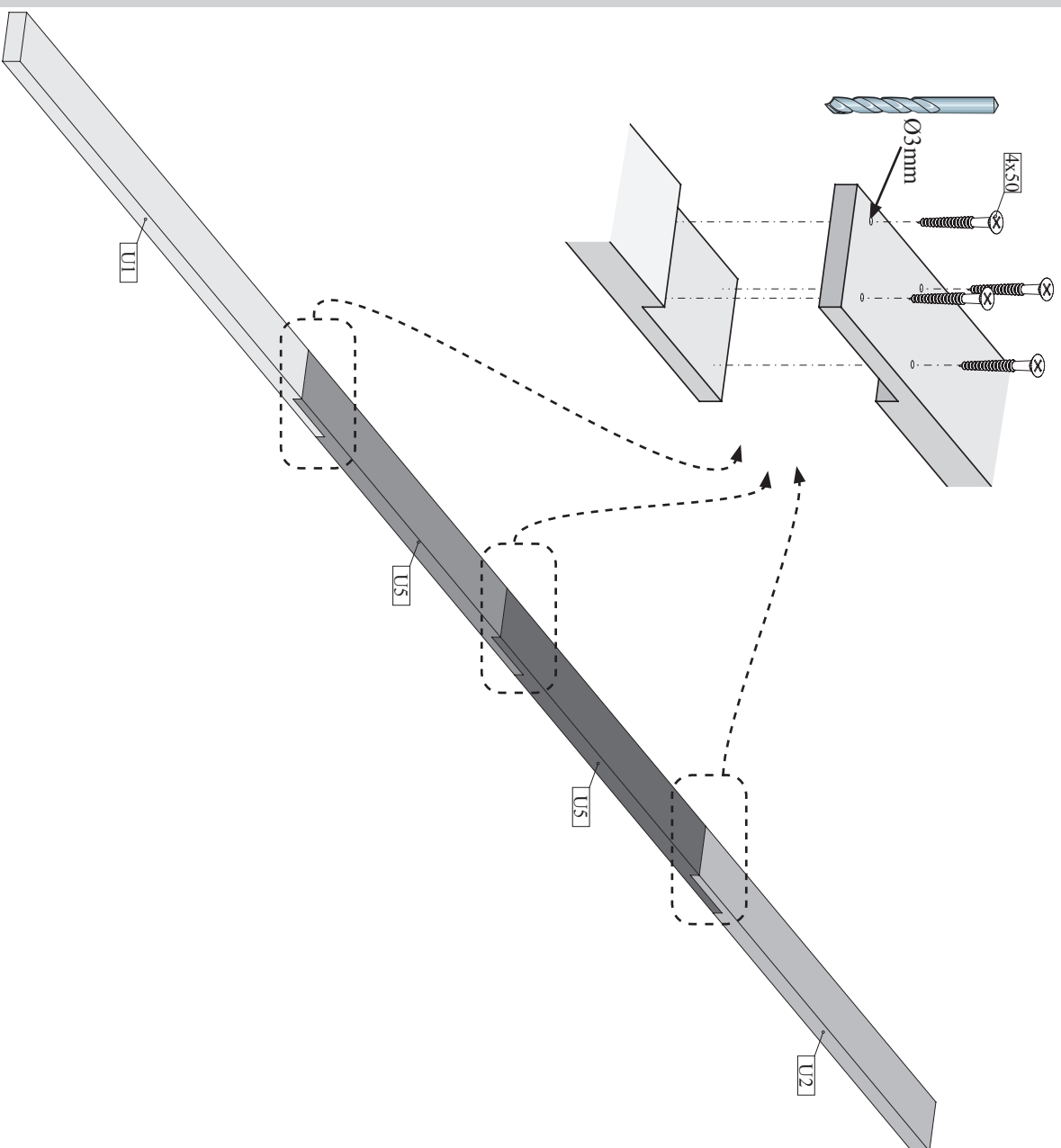
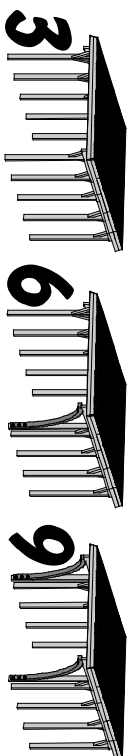

2.

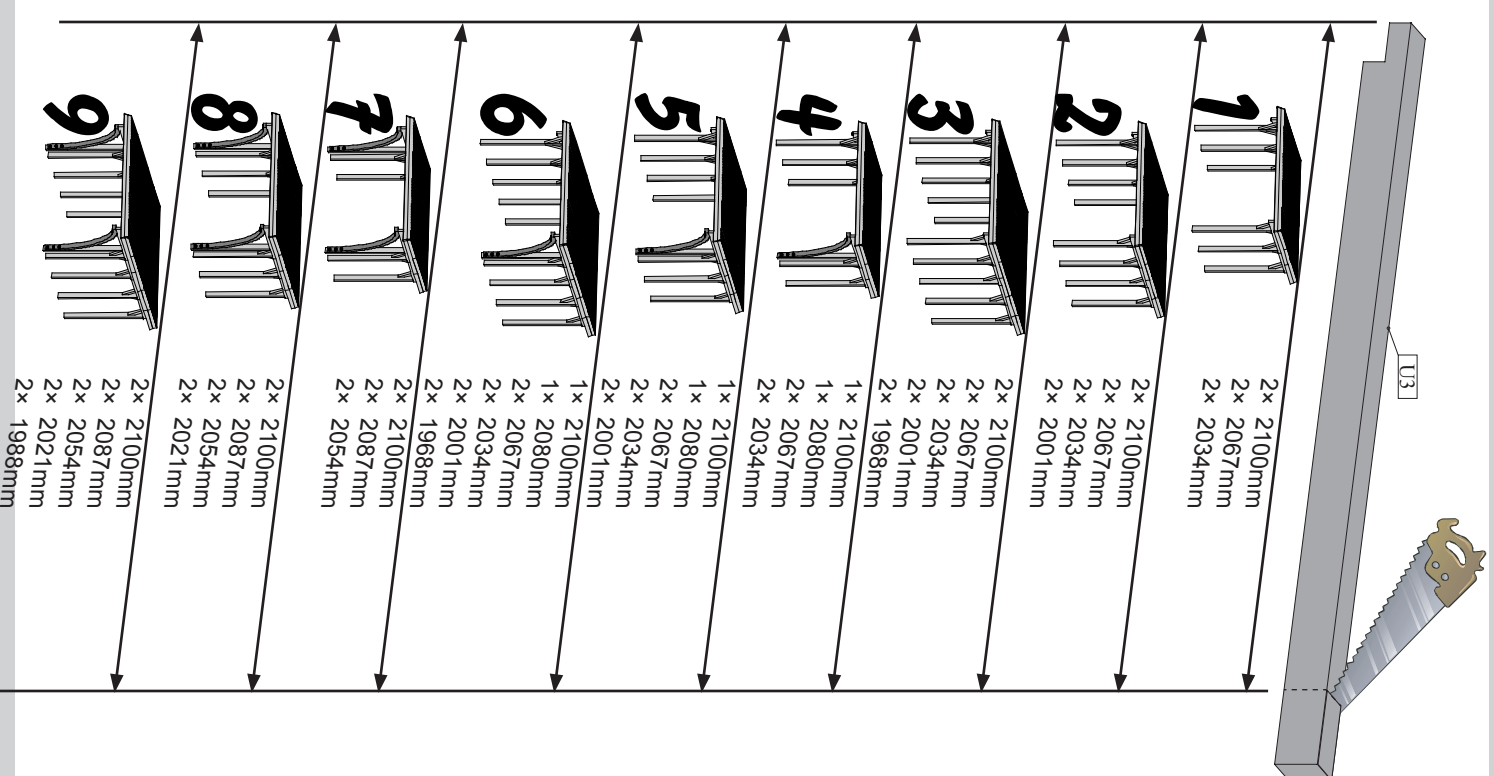

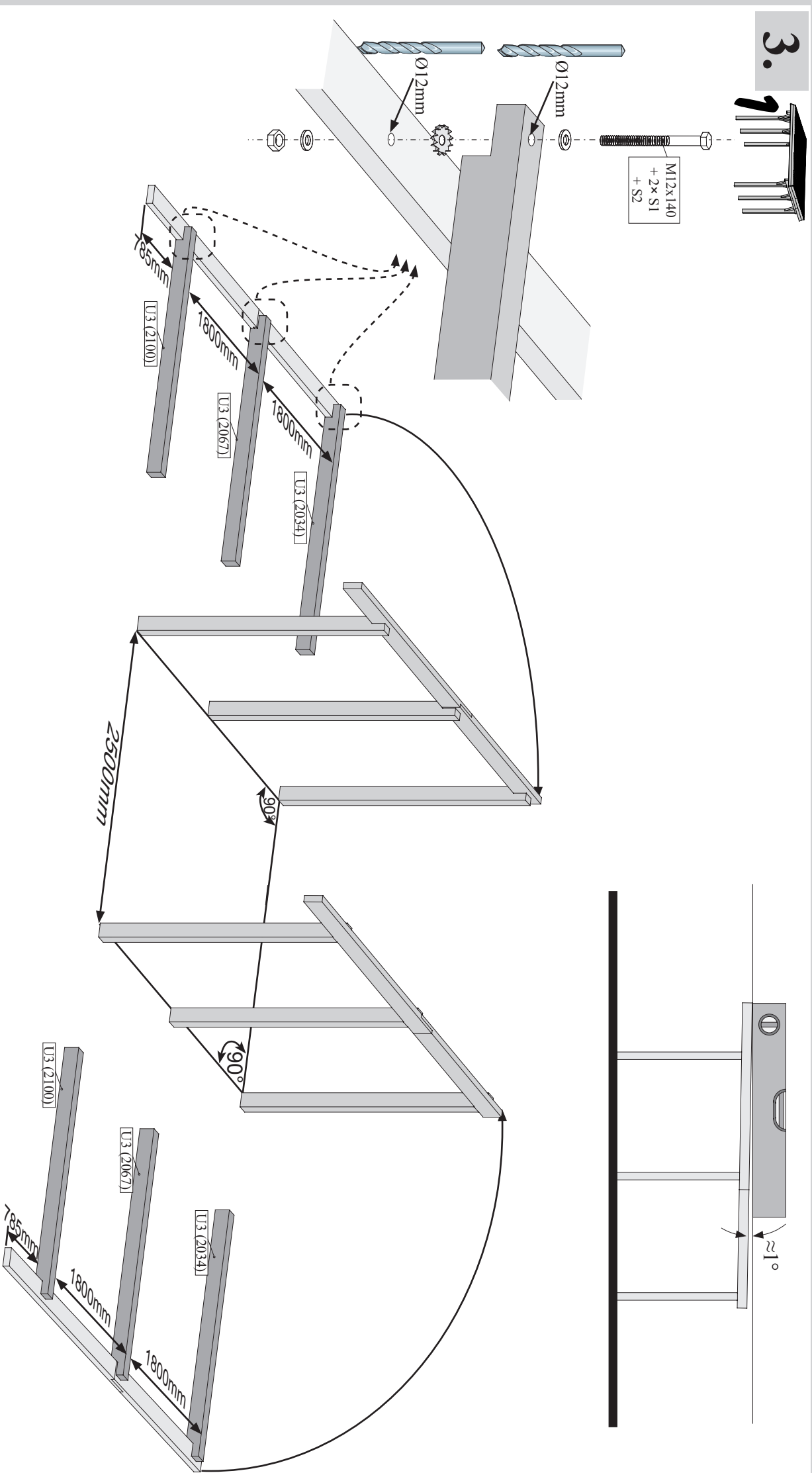

3.

2

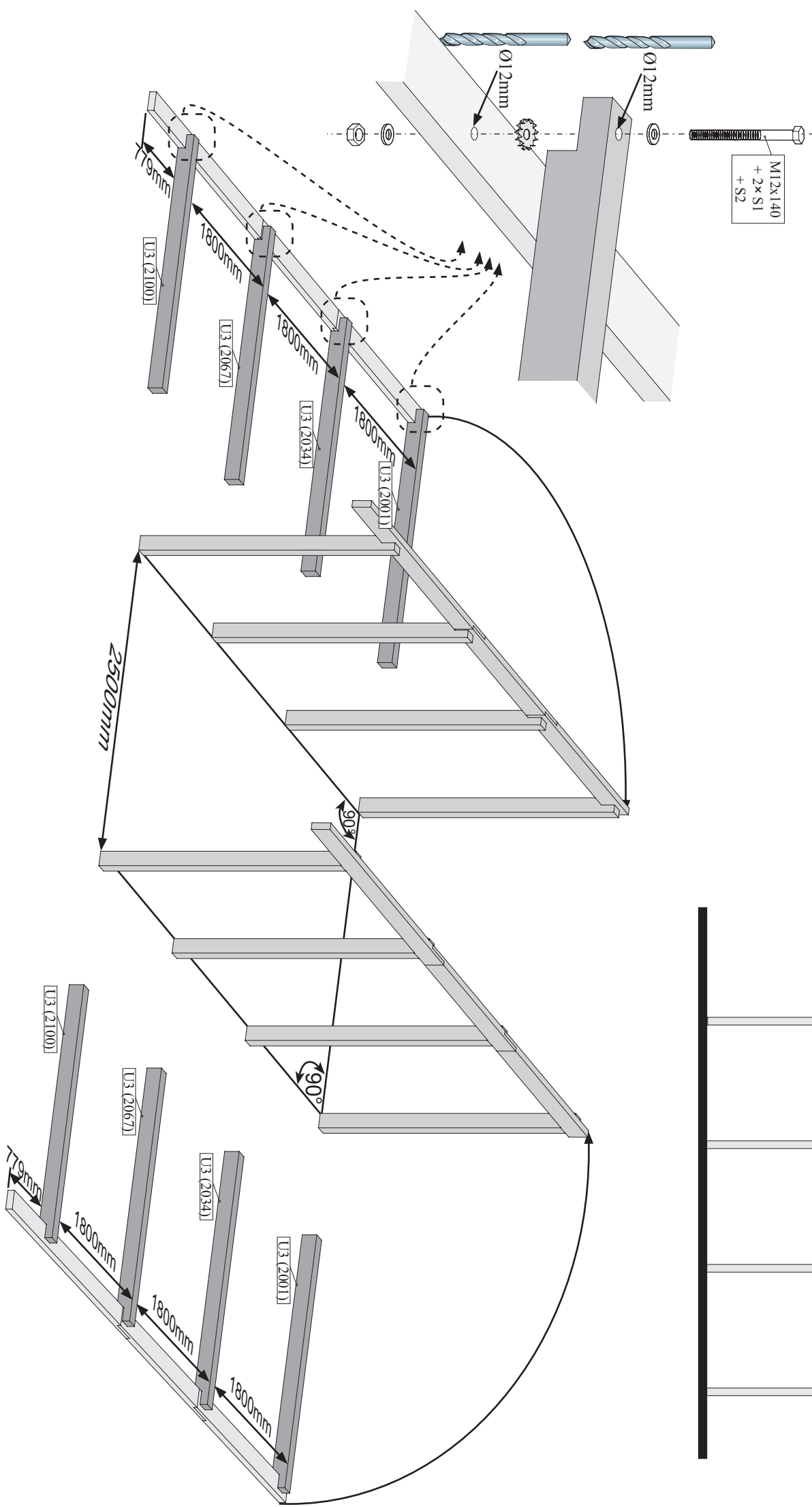

3.

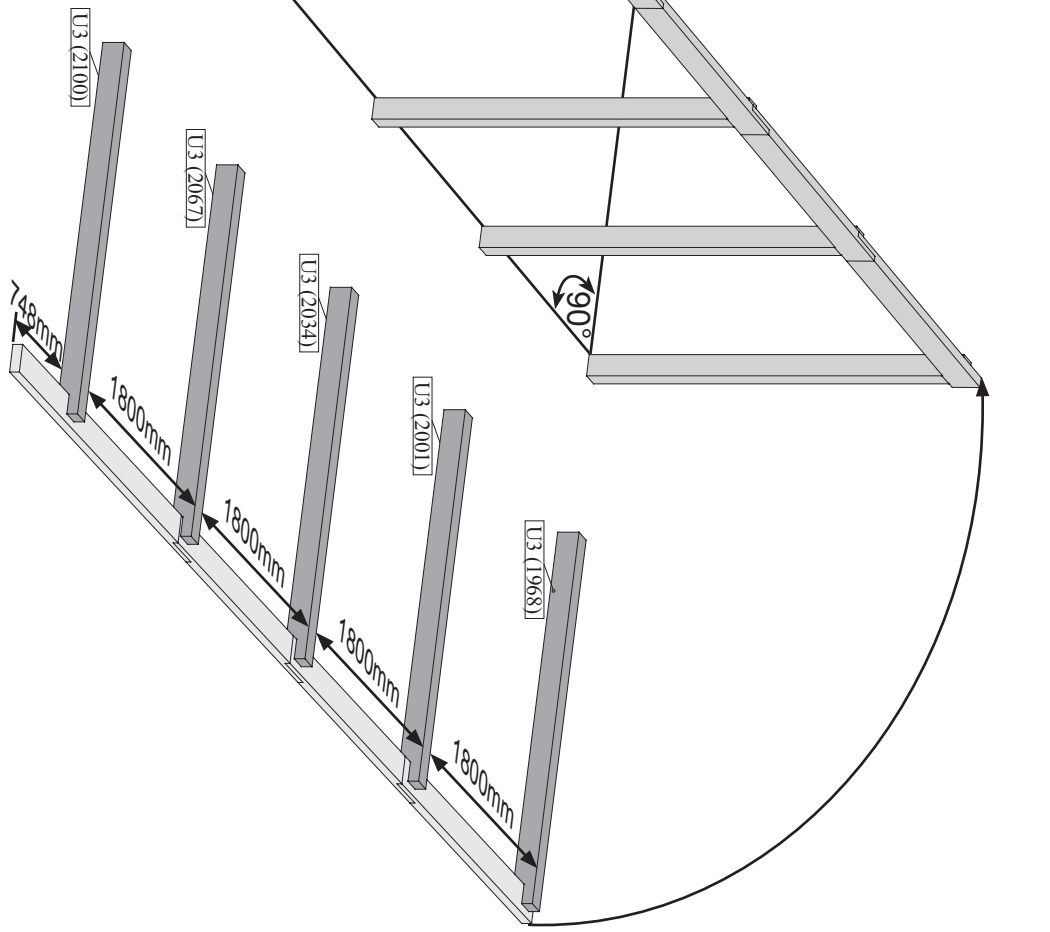
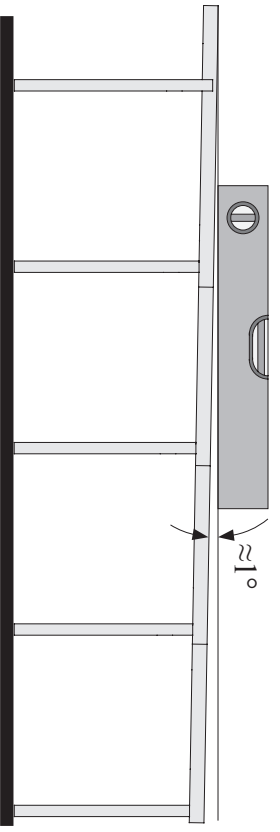
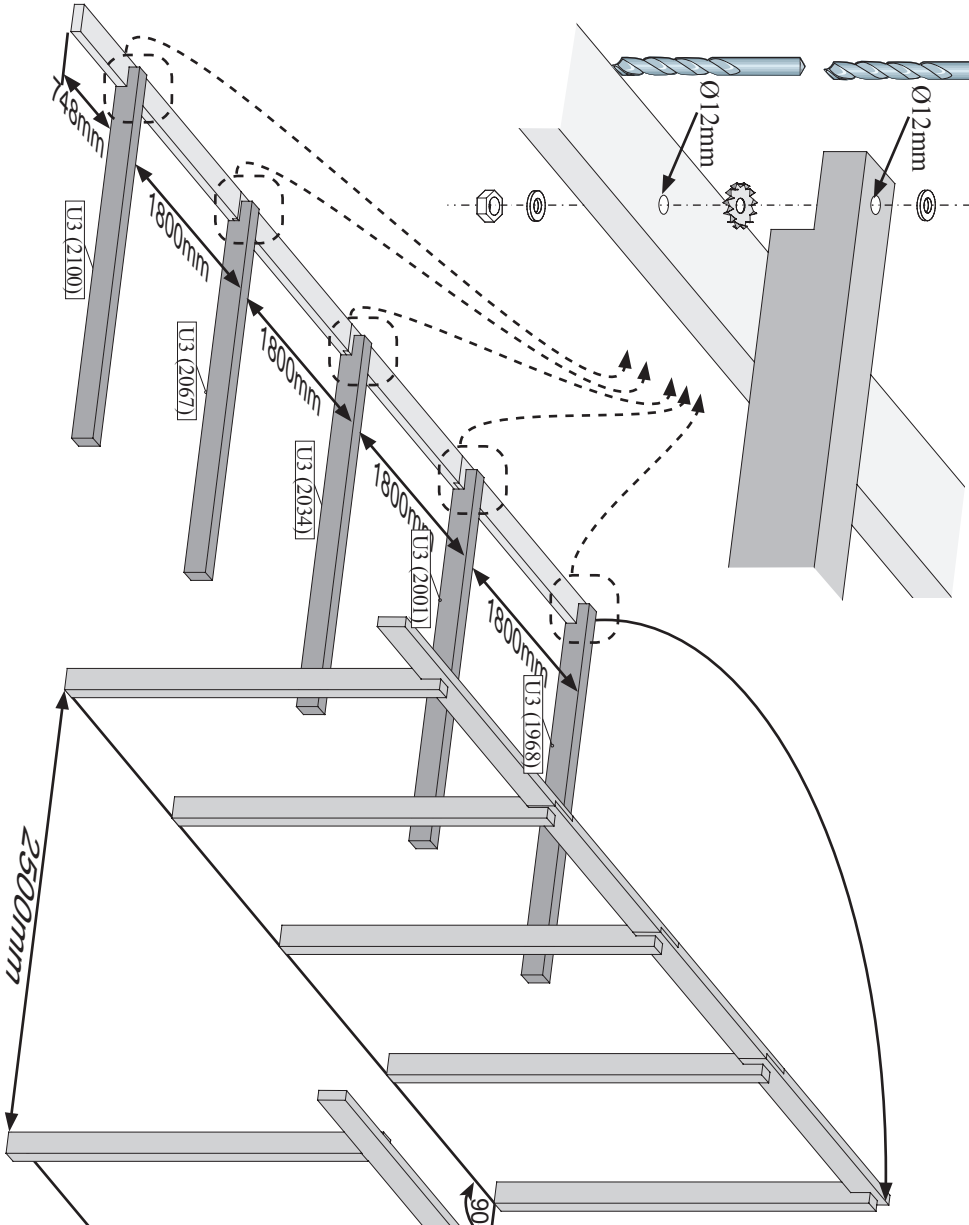
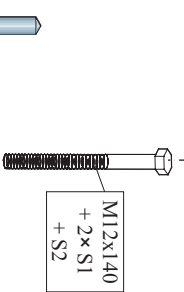

3.
4

M12x140
+ 2x S1
+ S2

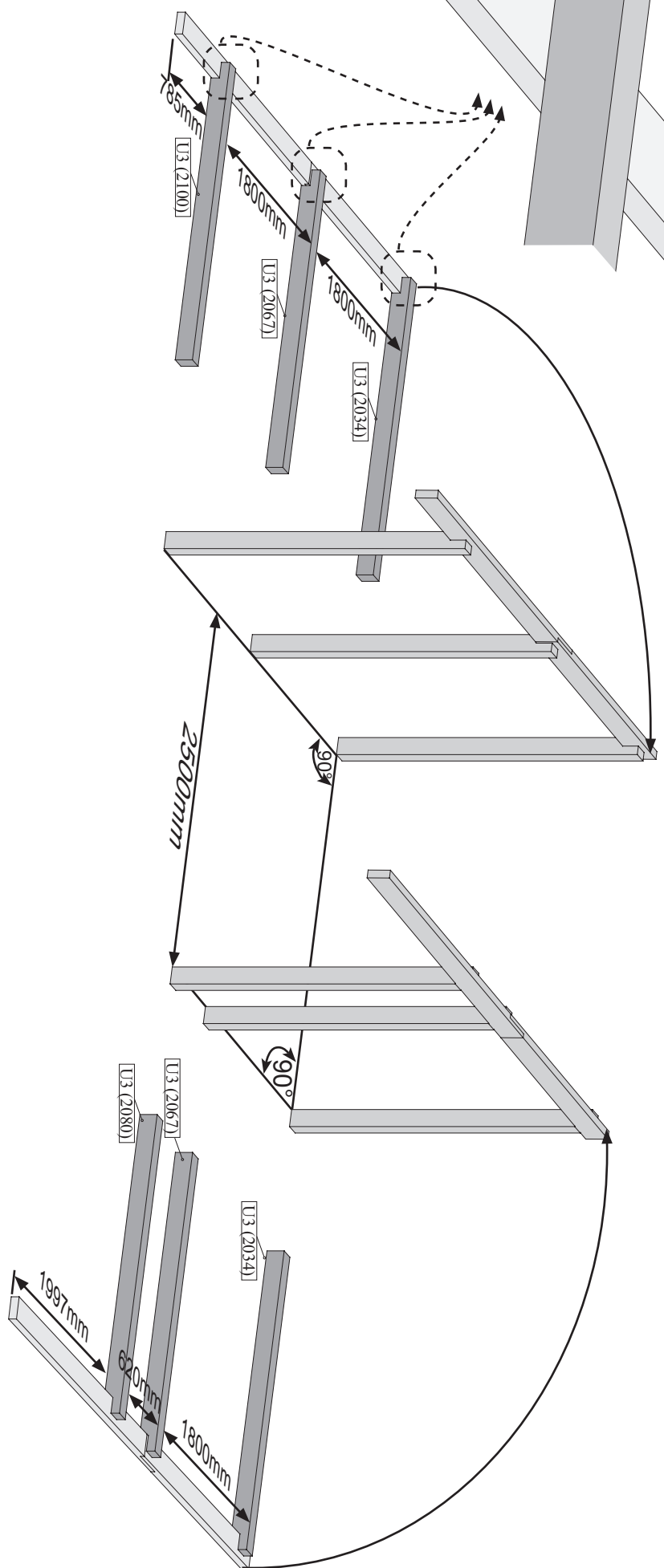
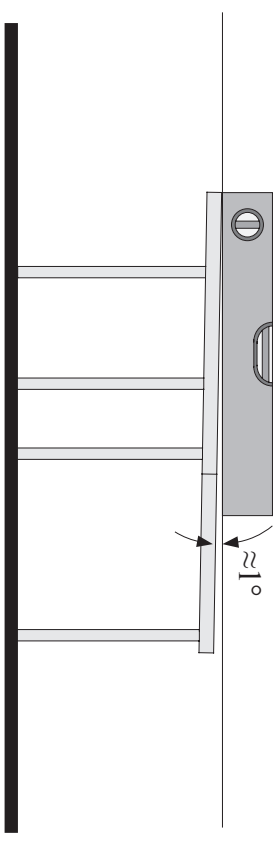
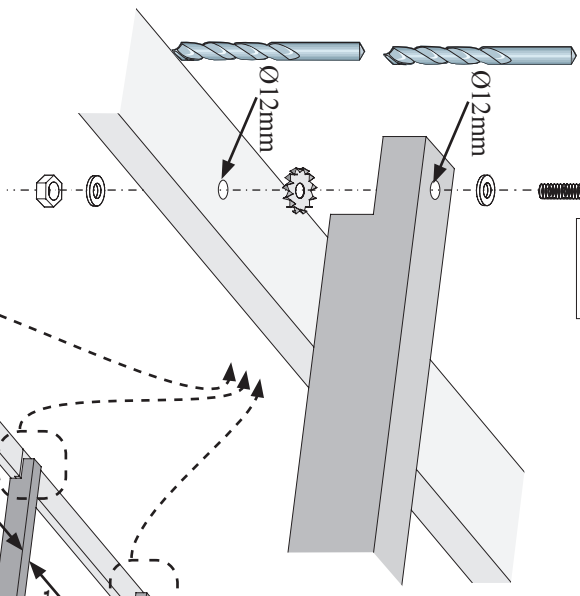

3. 5

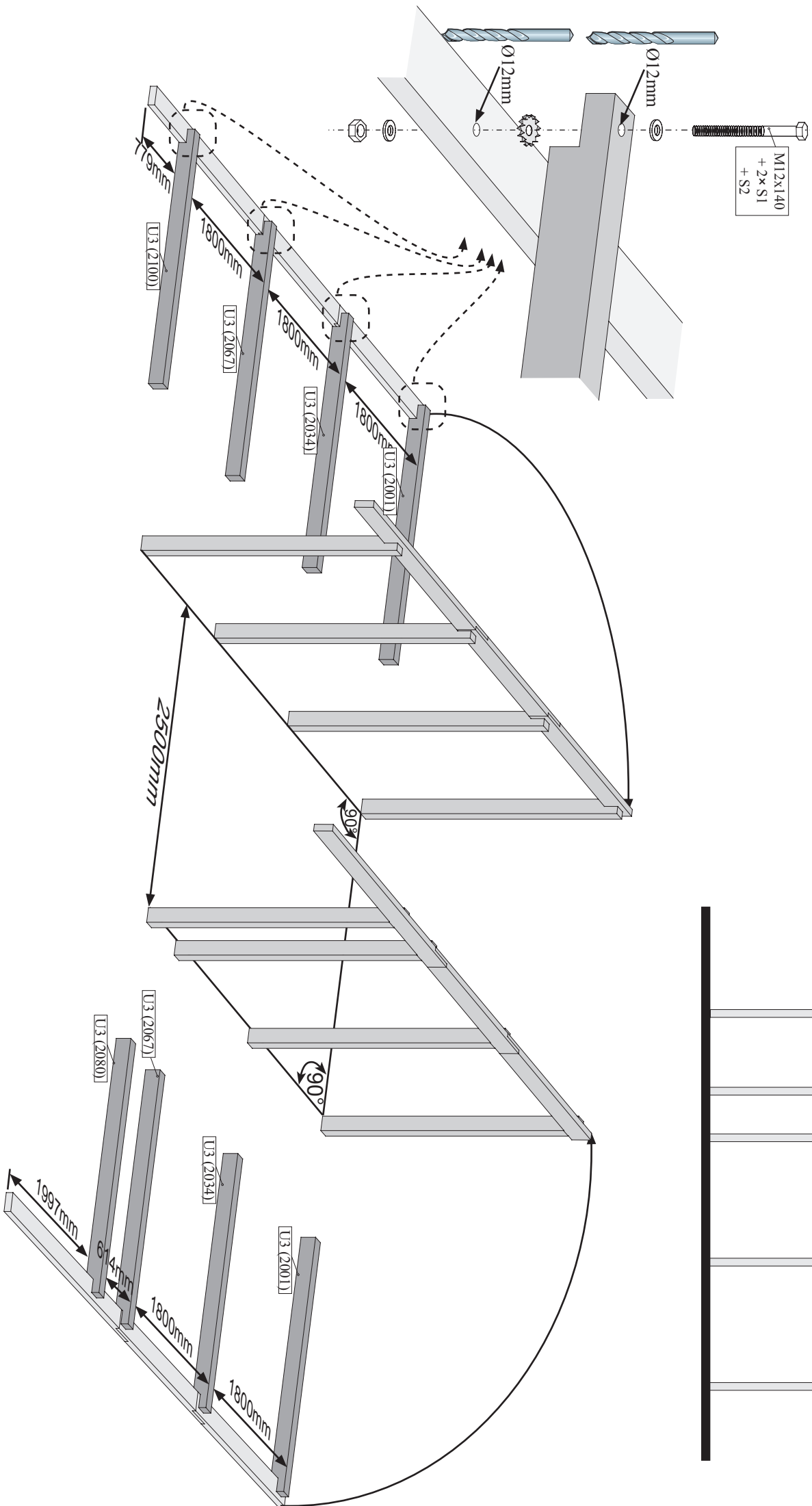

3.

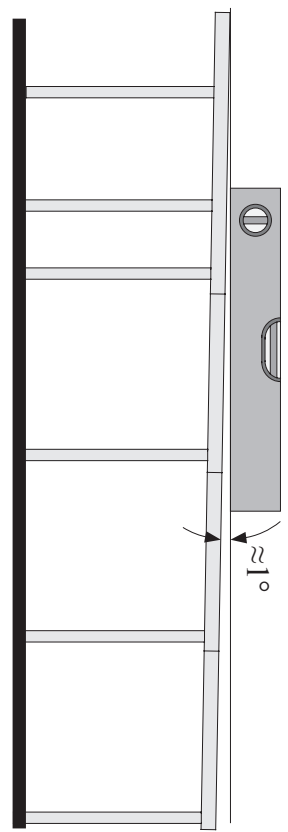
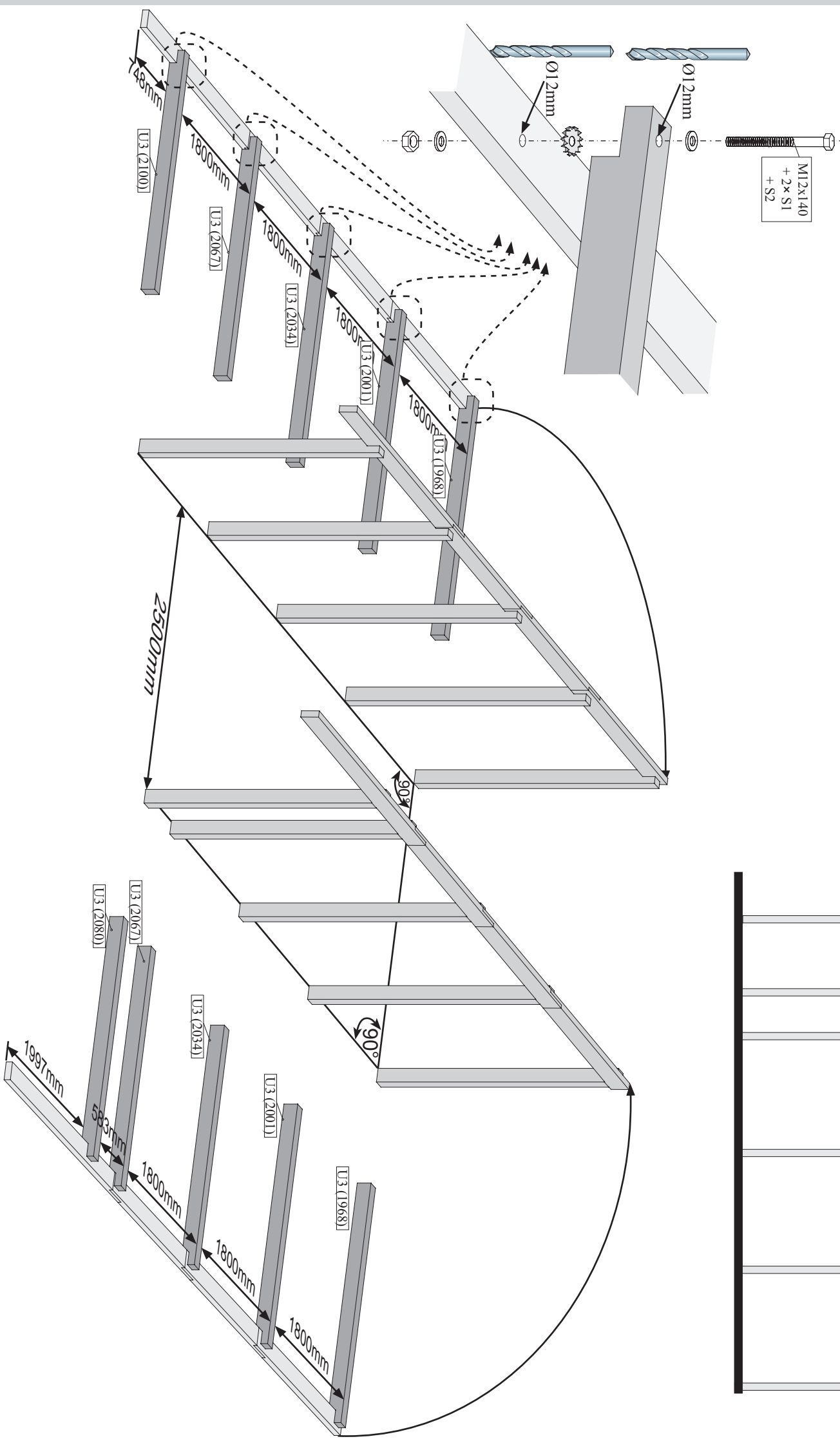
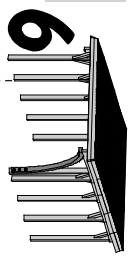

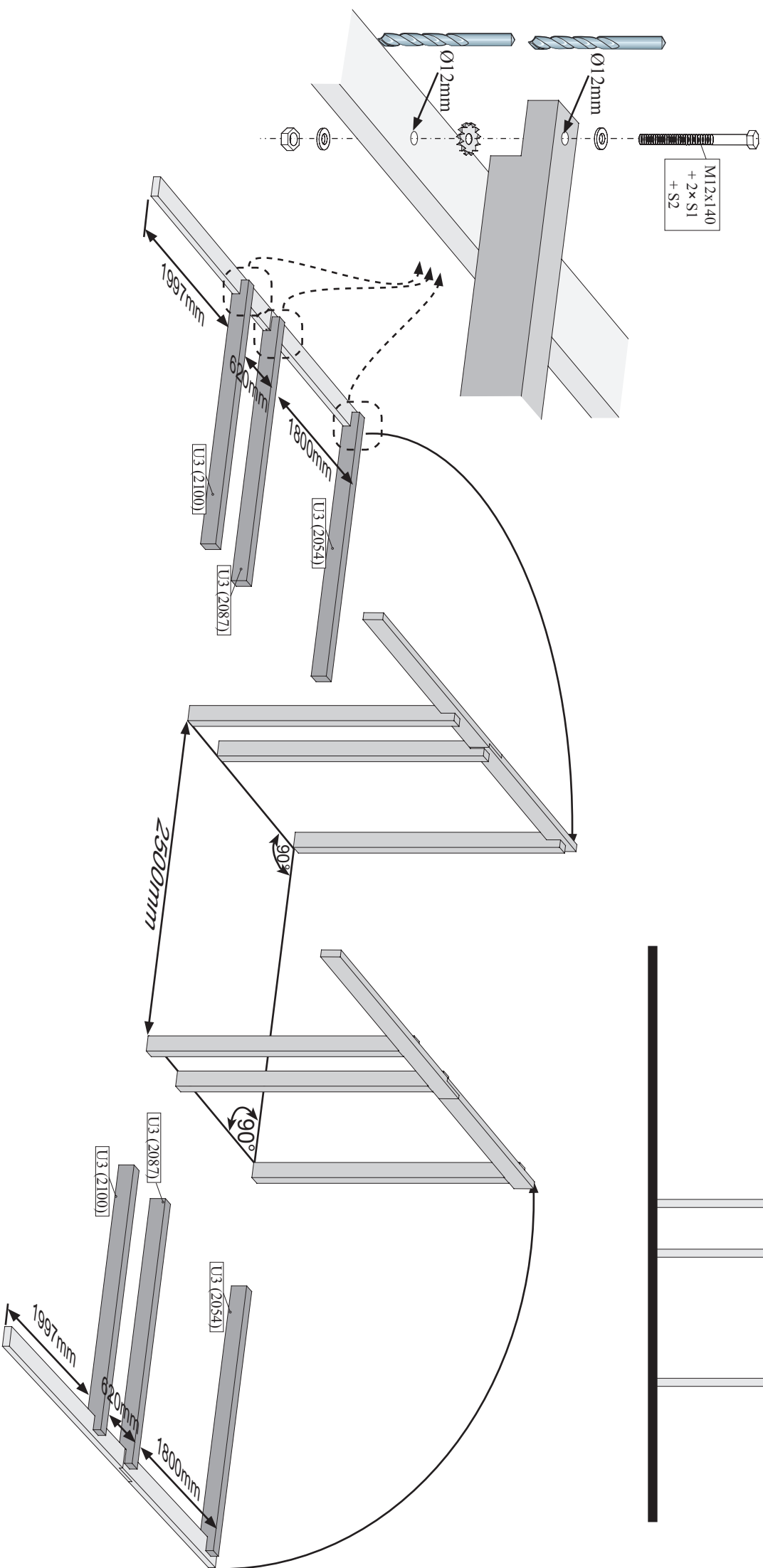
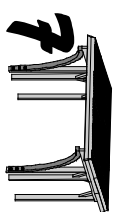

3. 8

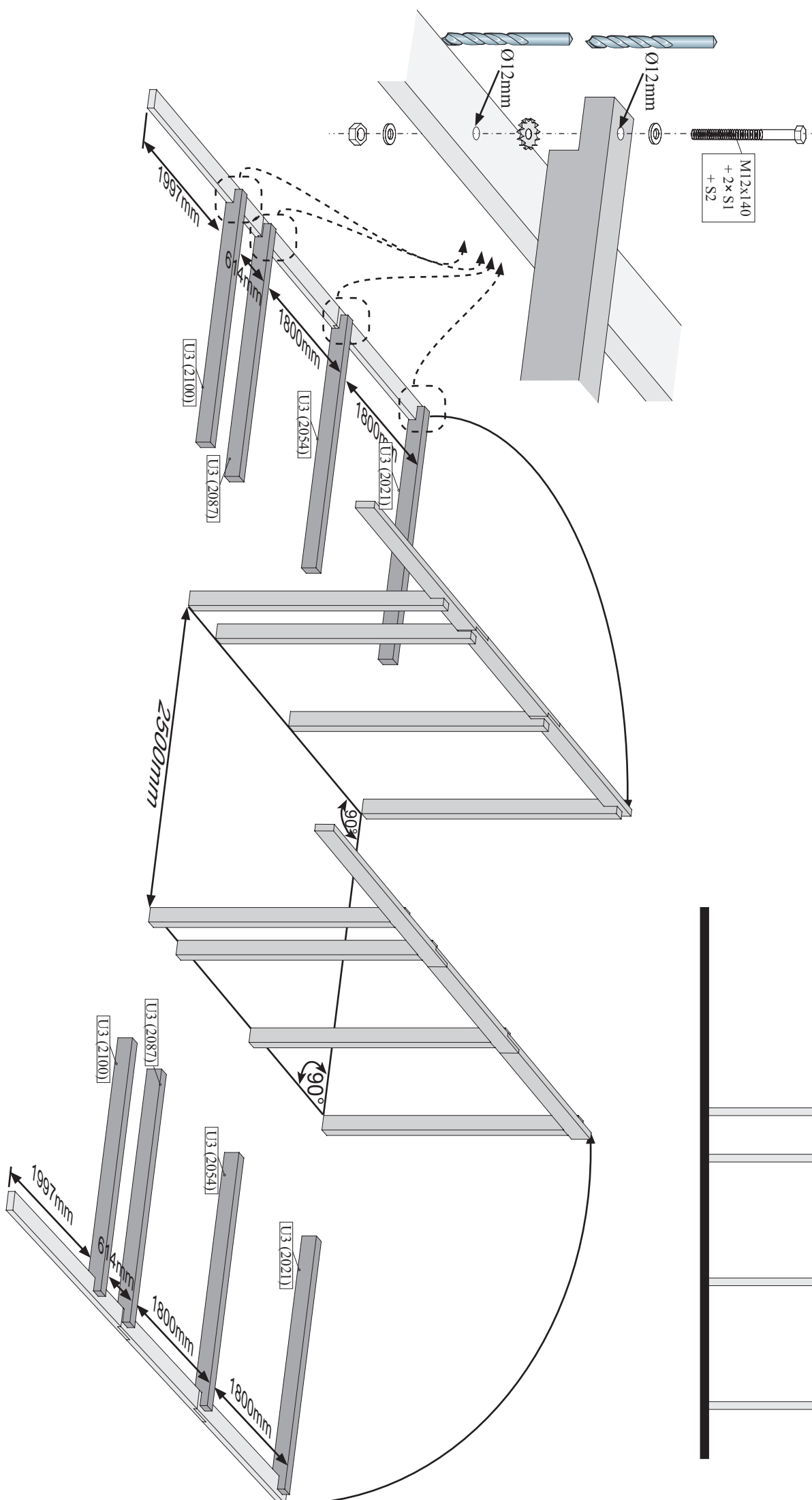

3. 9

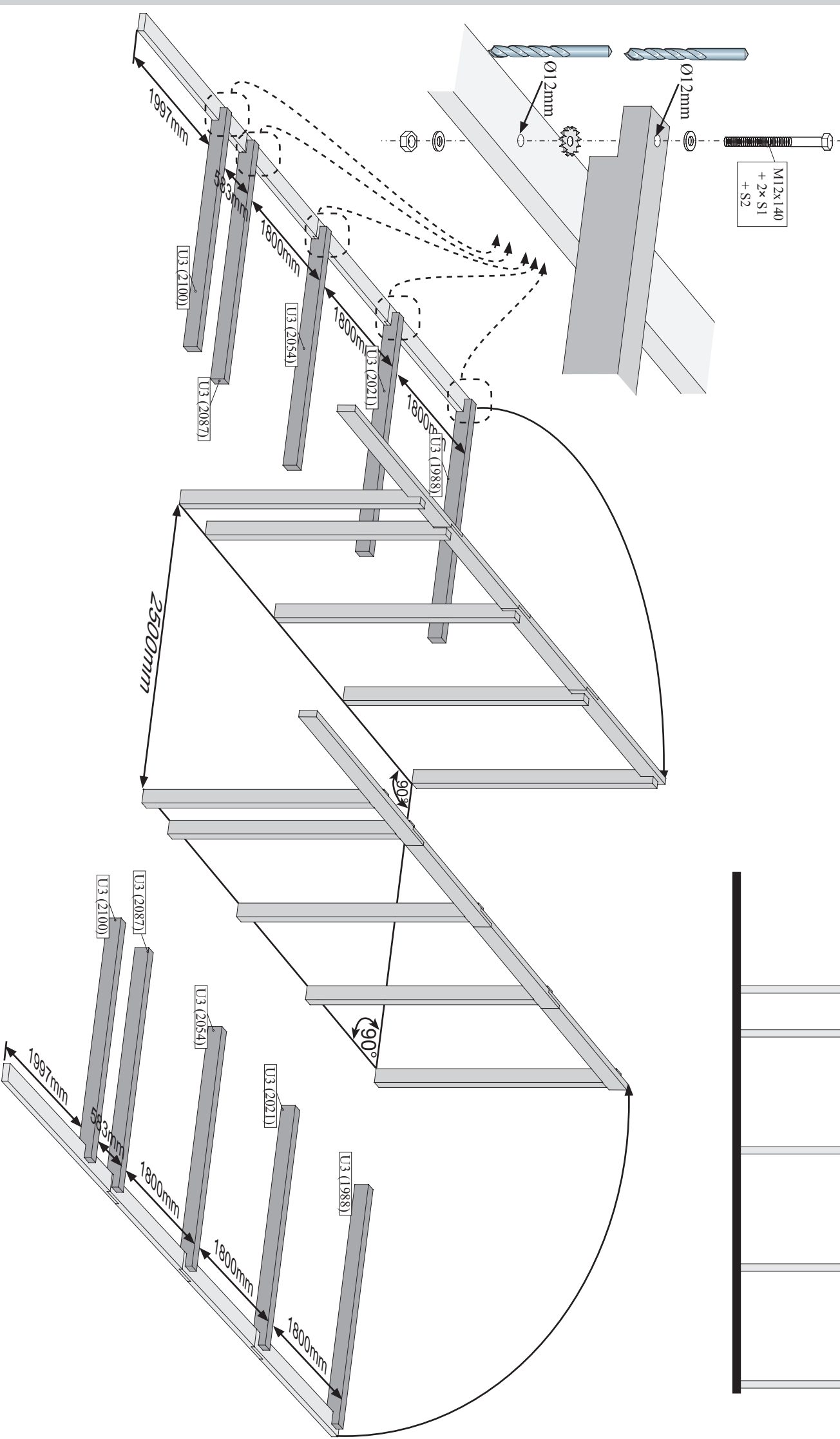

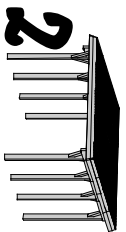

2

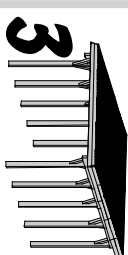
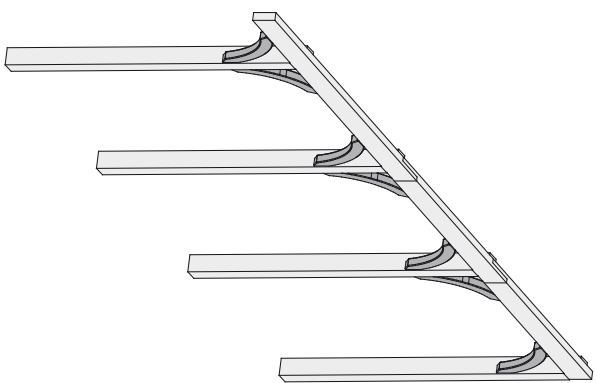
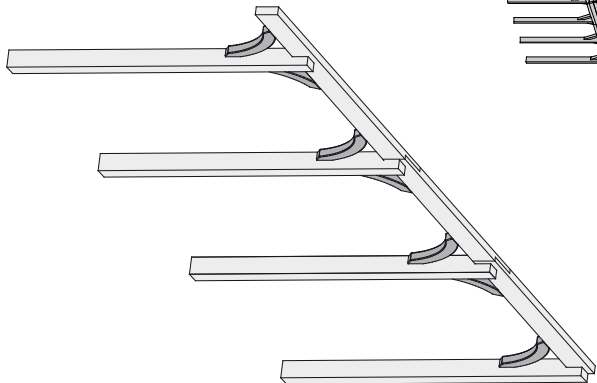

3

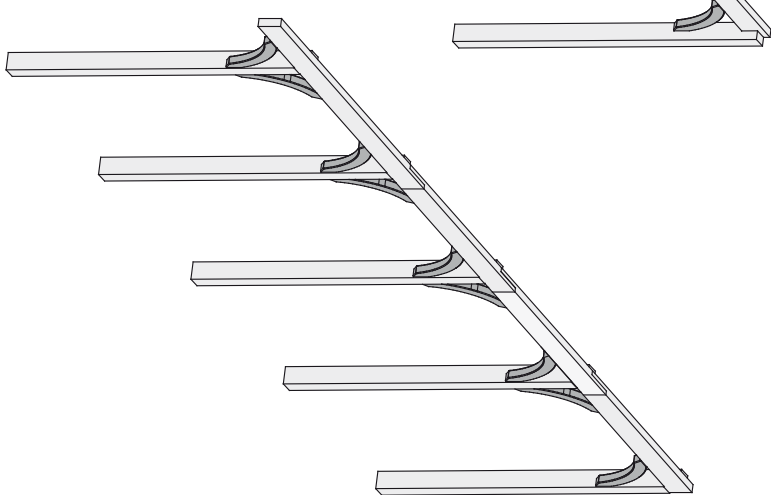
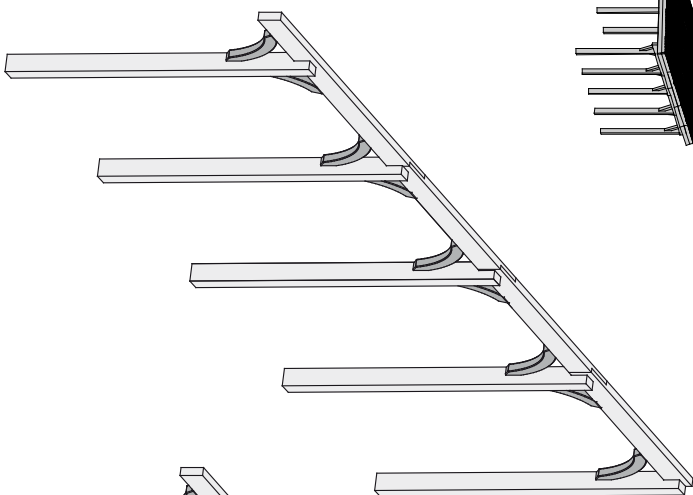

4.

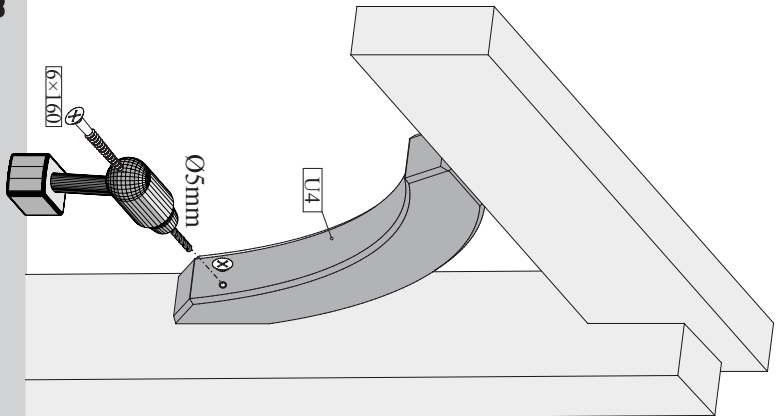

5.

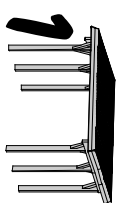
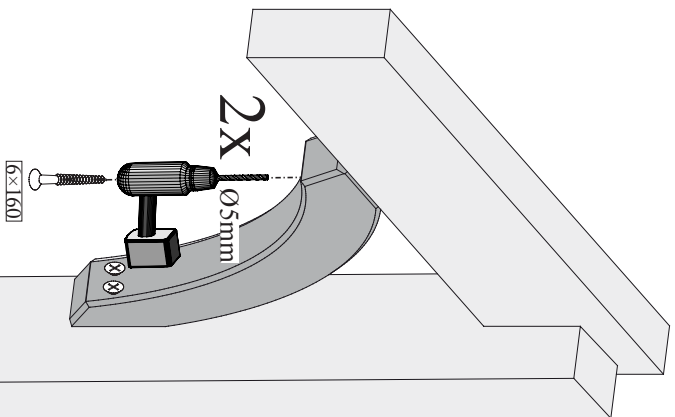

6

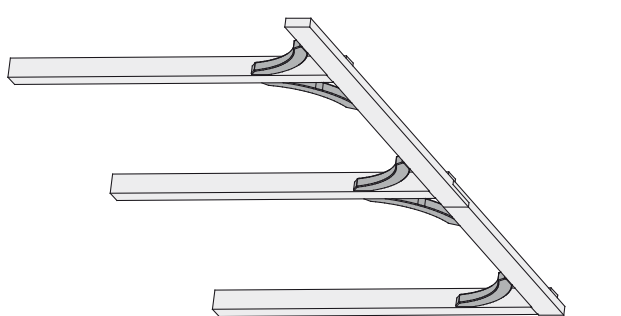
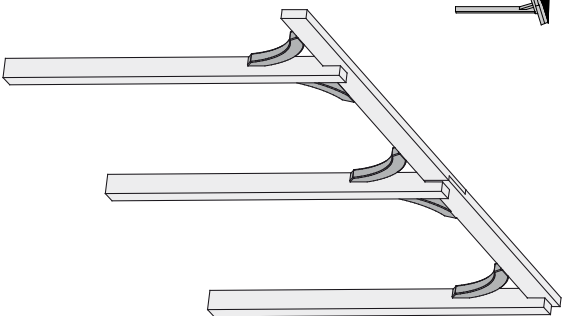

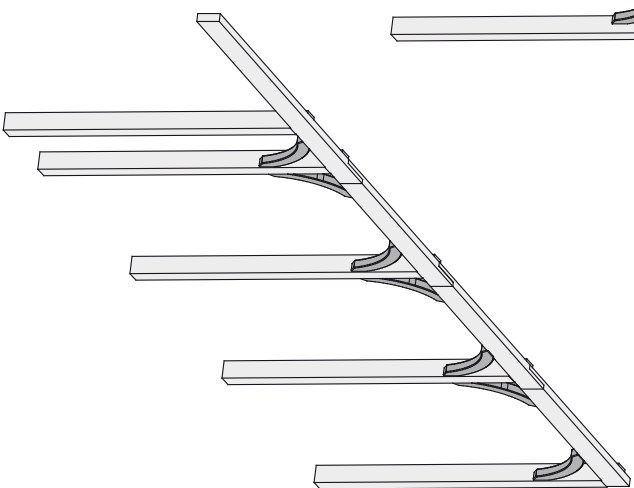
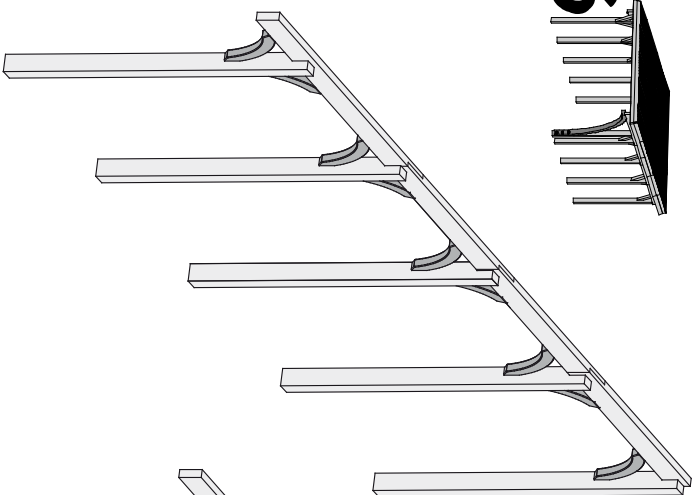
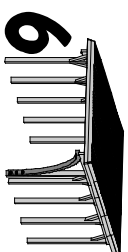
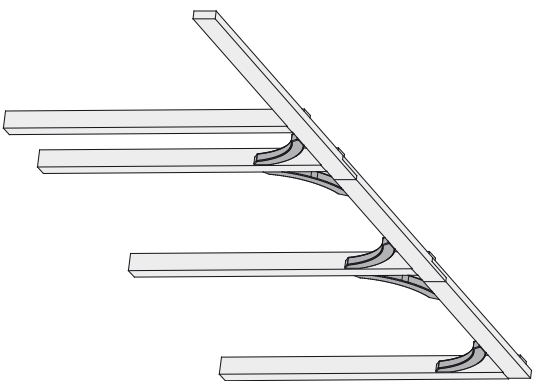
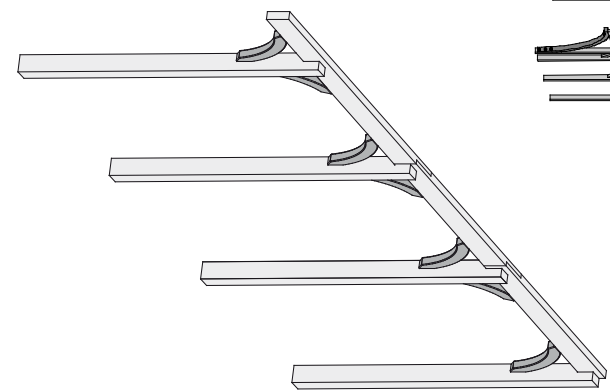
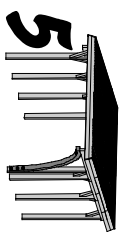

4.

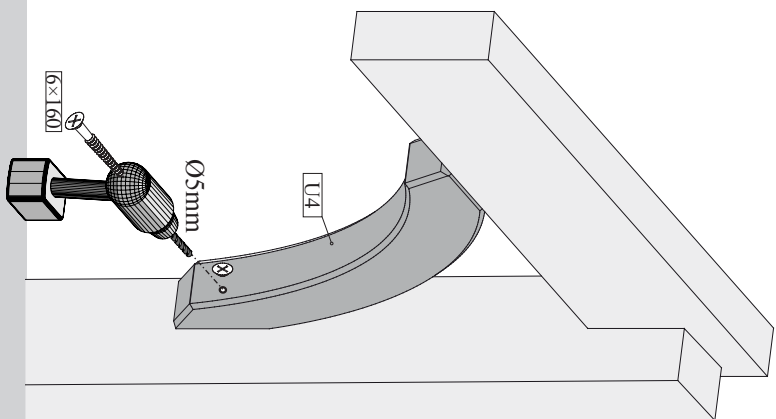

5.

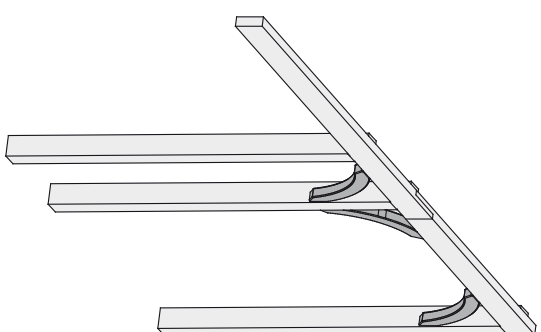
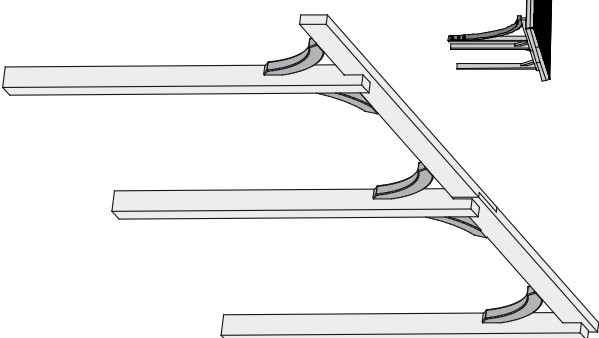
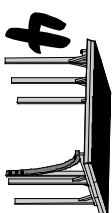
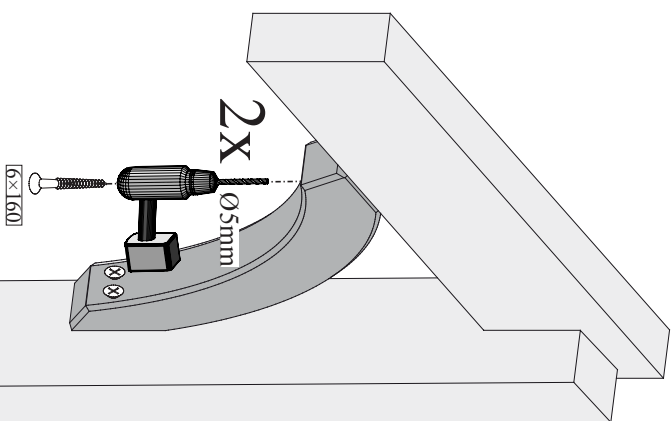

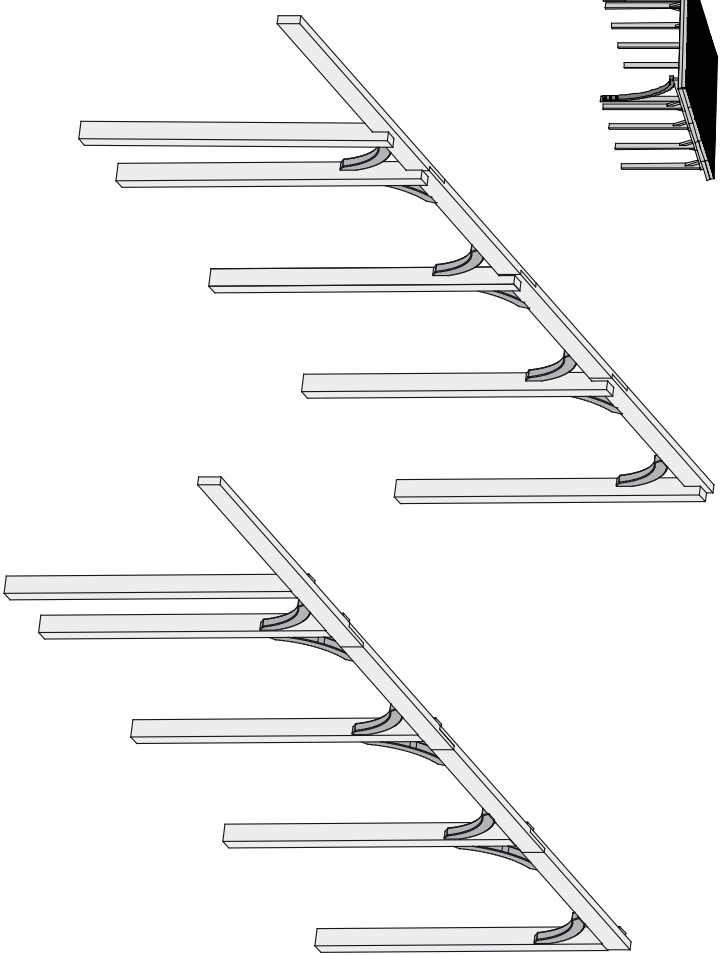
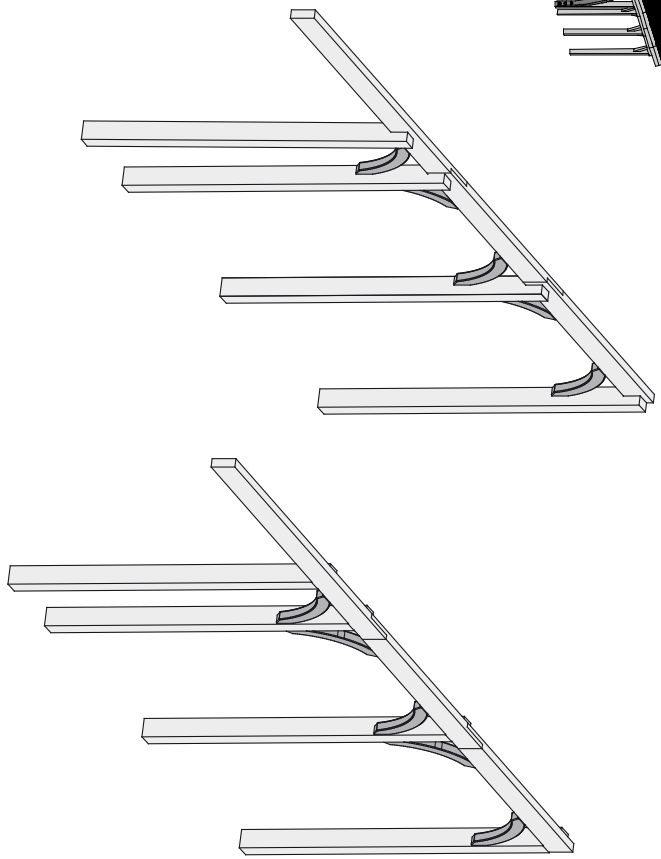
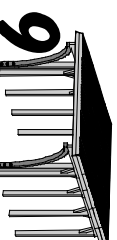
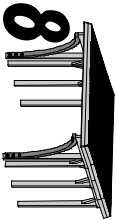

4.

5.

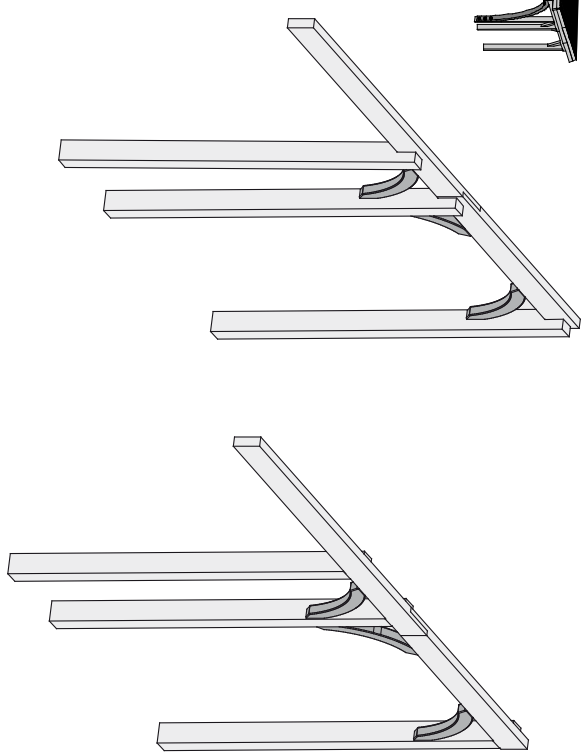
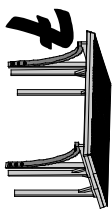
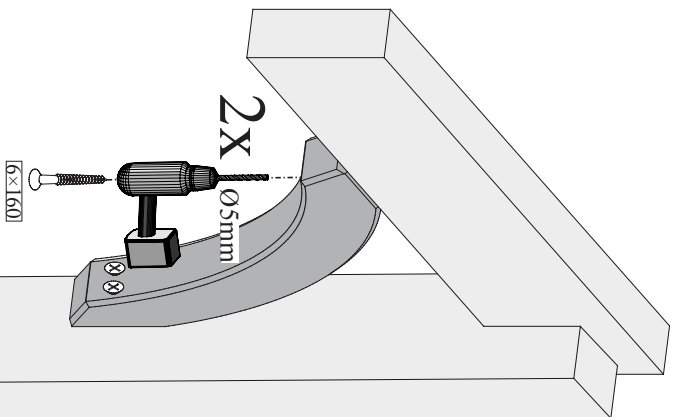
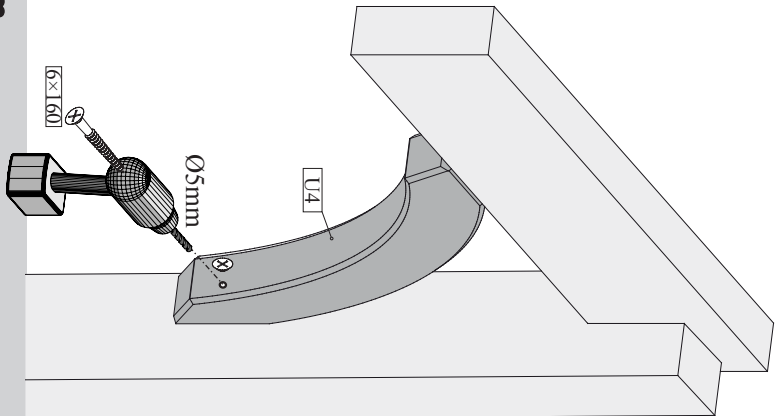

6.

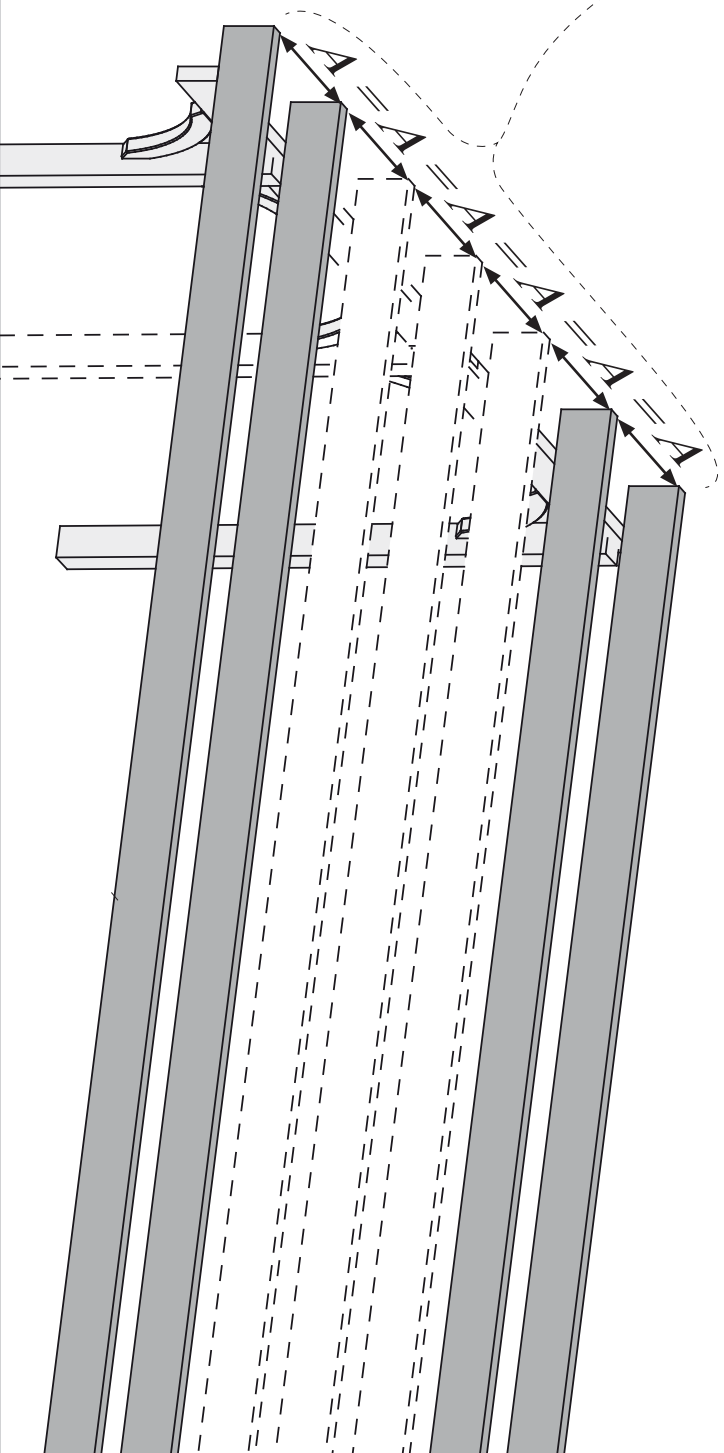
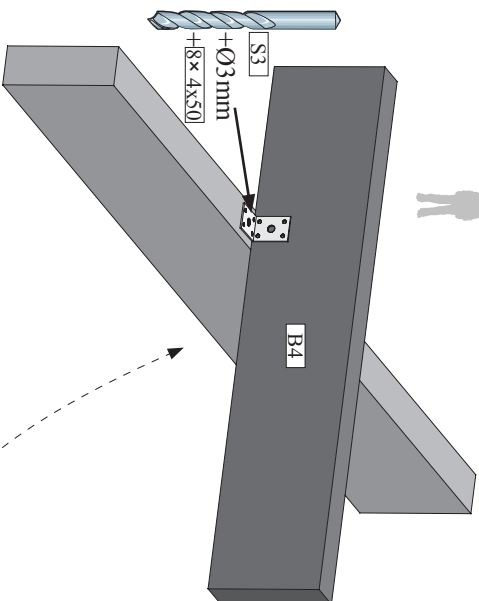
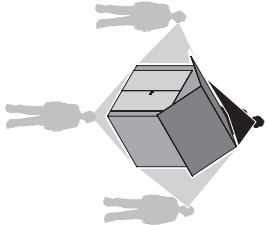
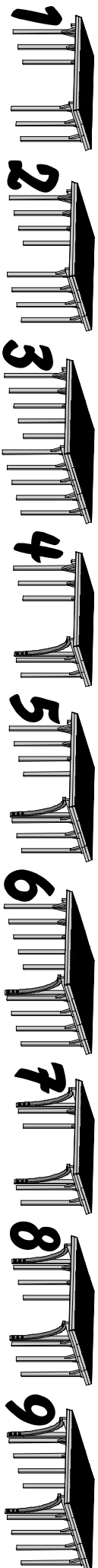

7.

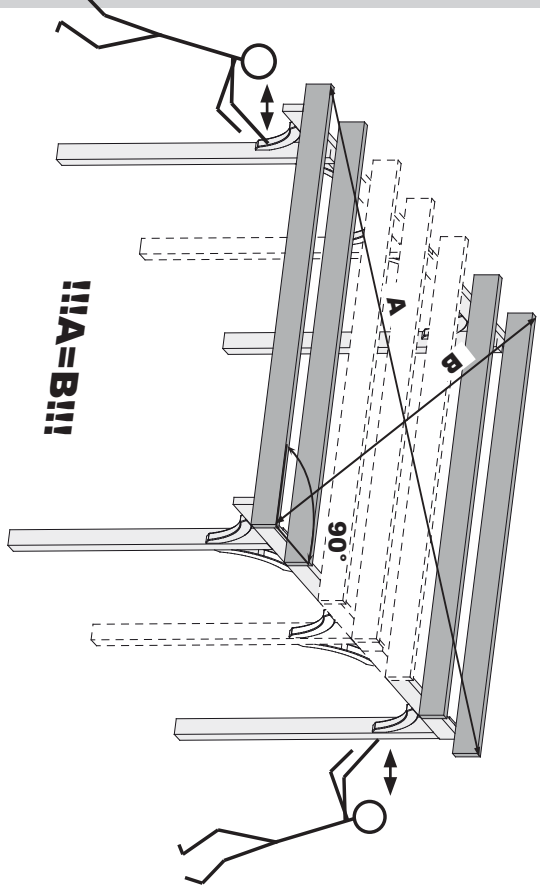
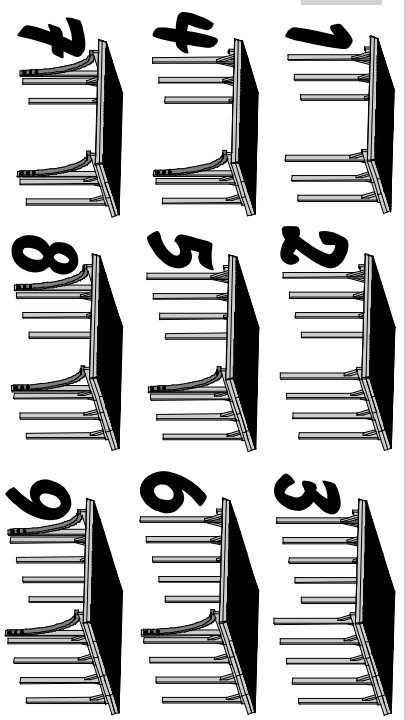

8.

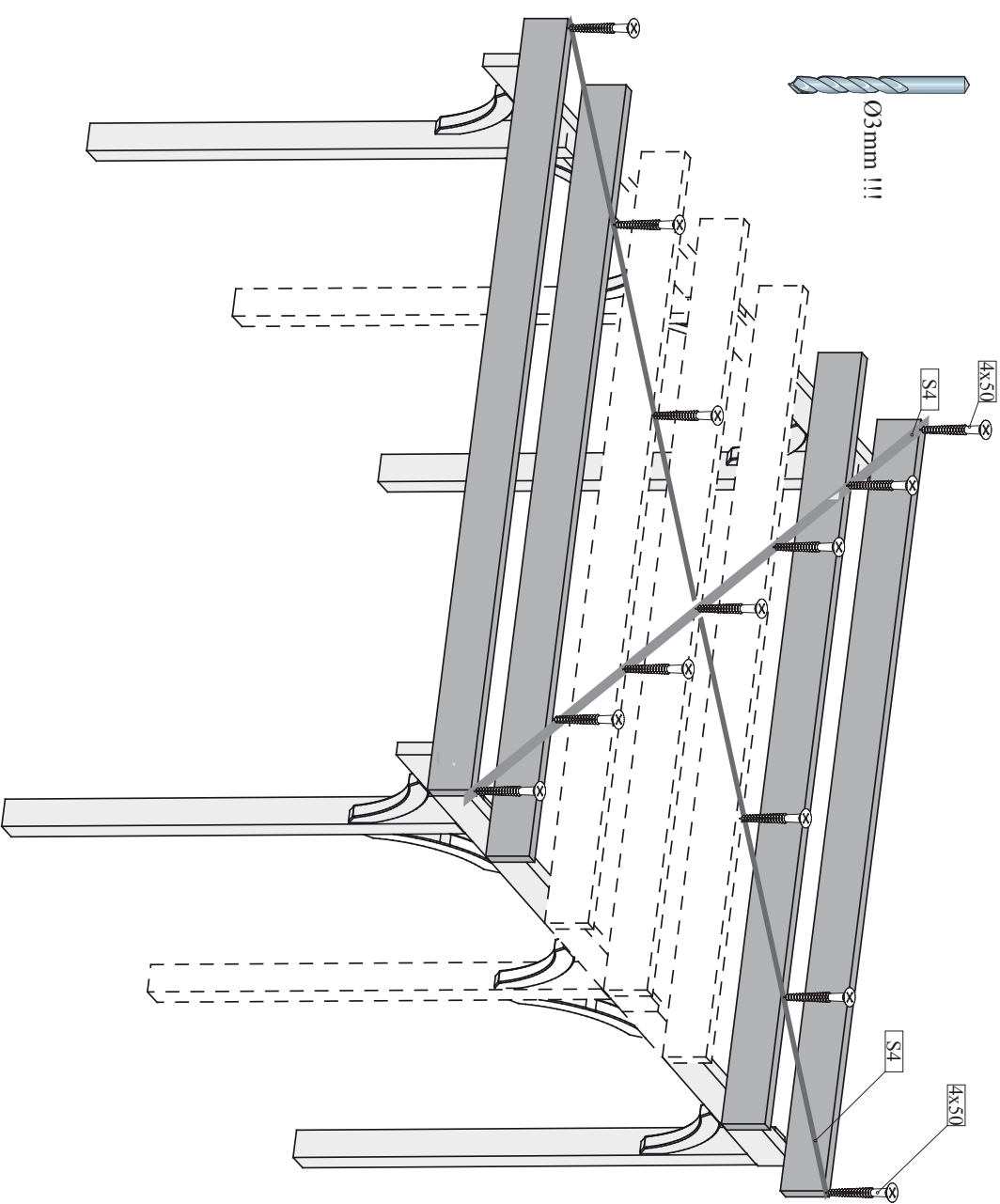
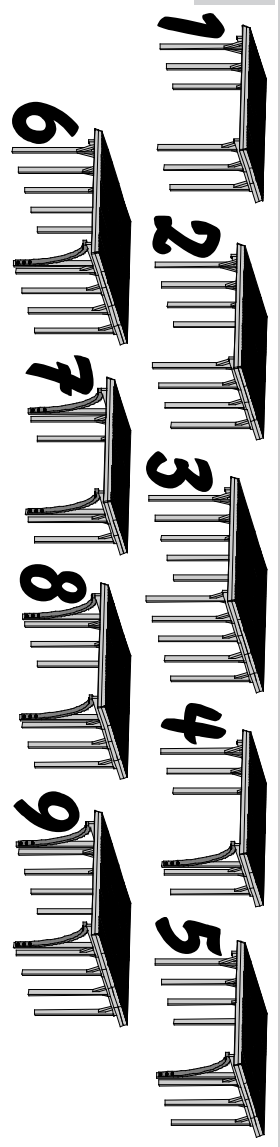

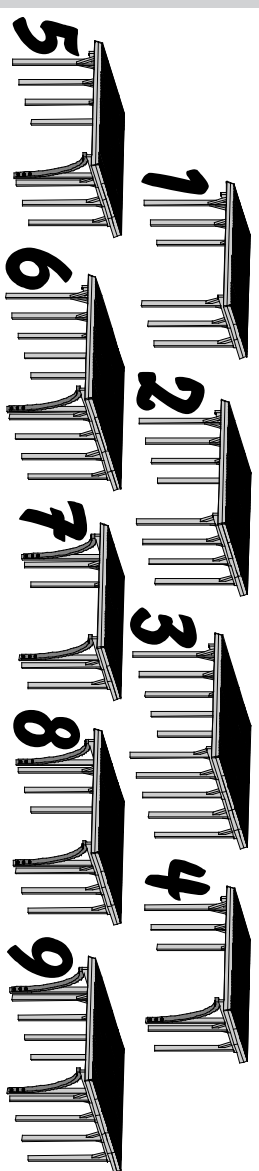

10. 5x

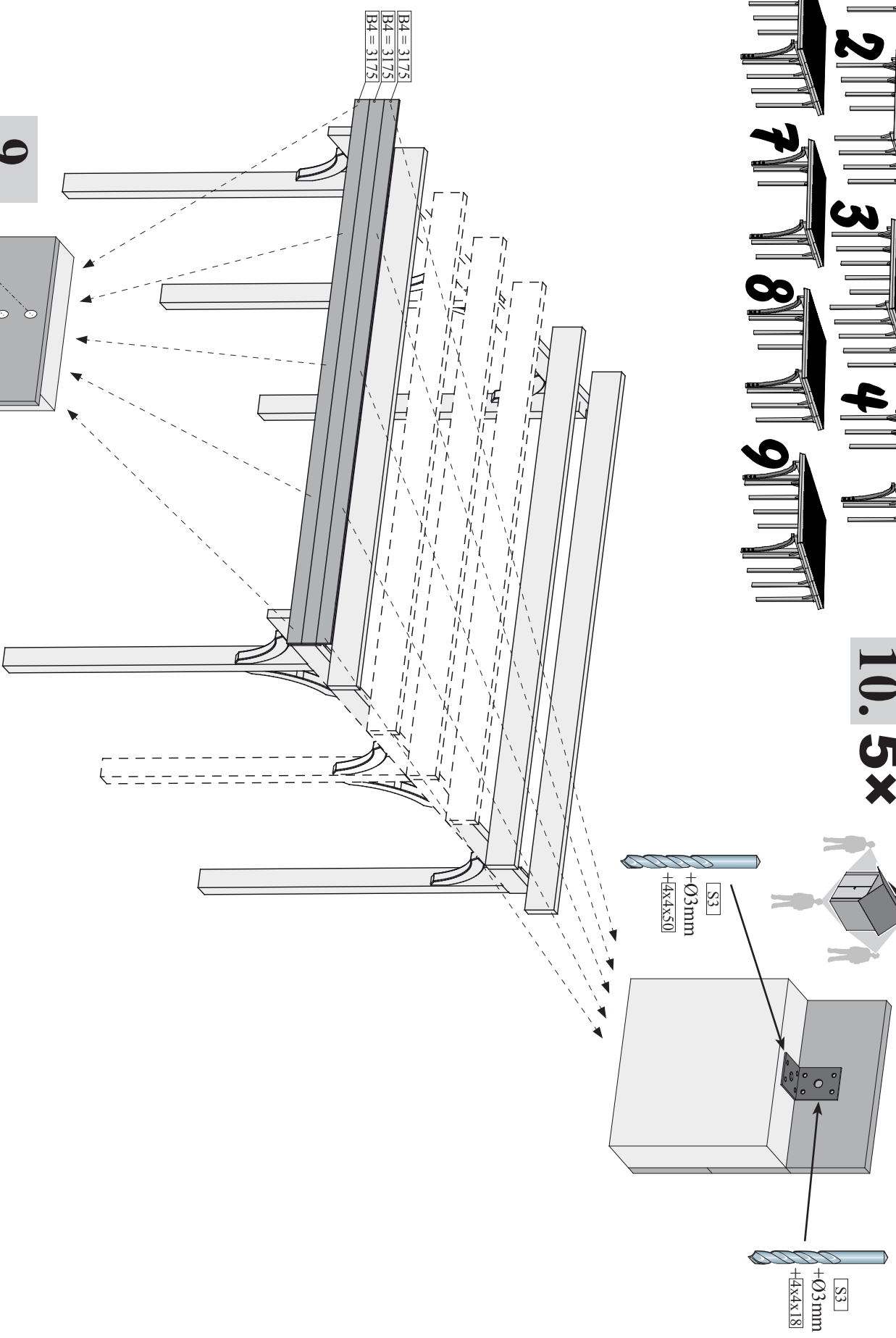
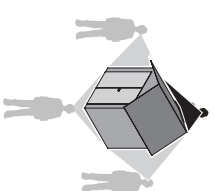

9.

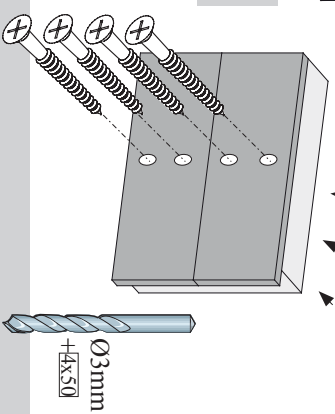

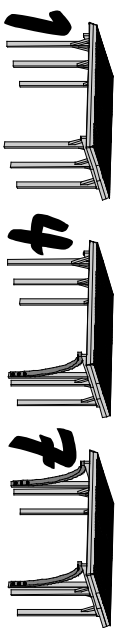

10.

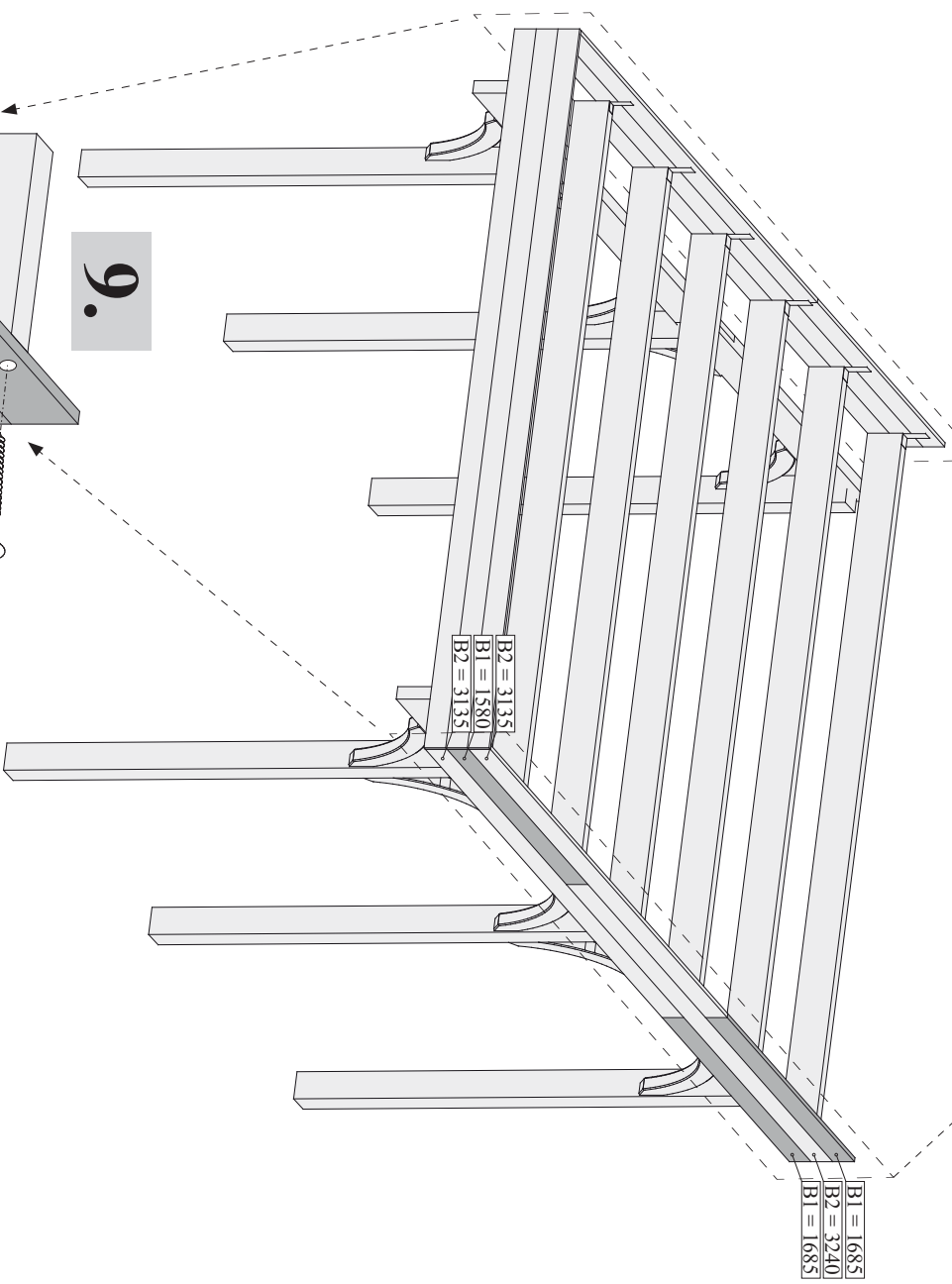
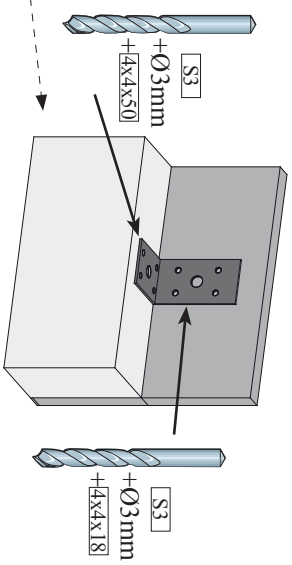

9.

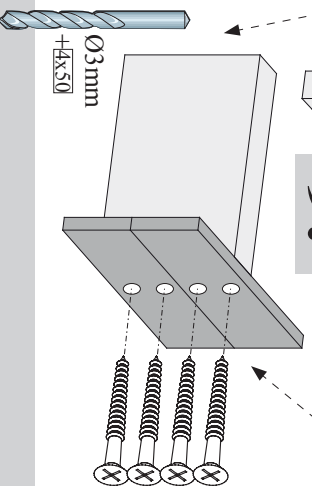

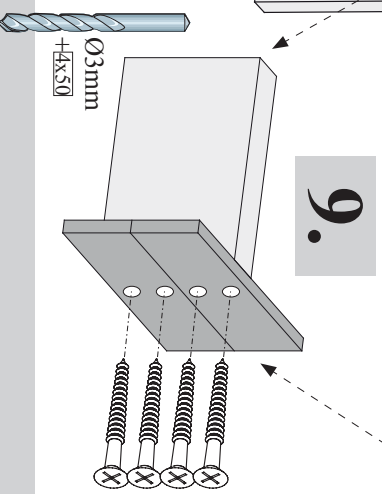
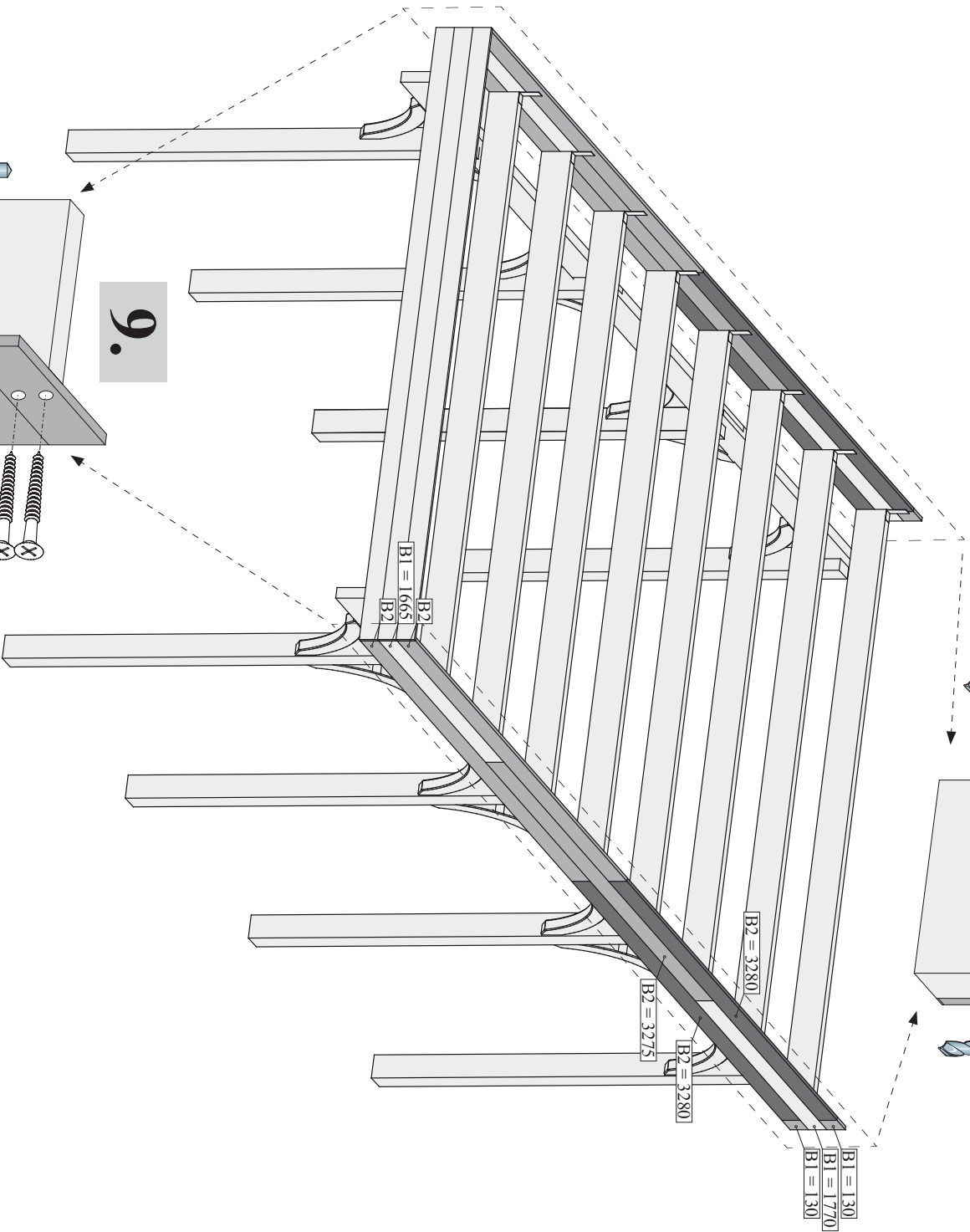
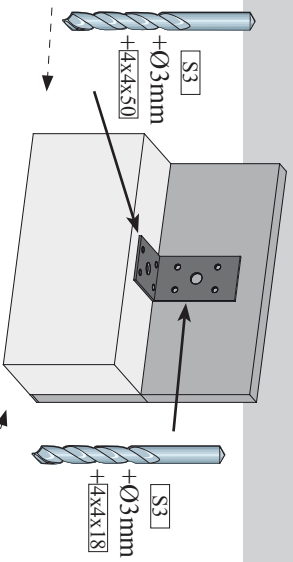

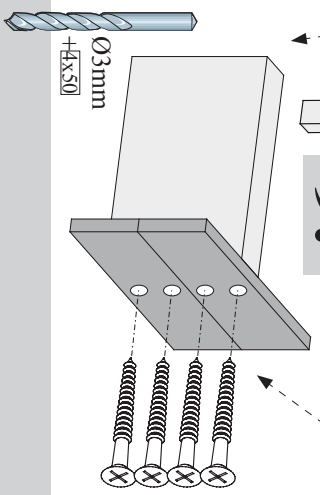
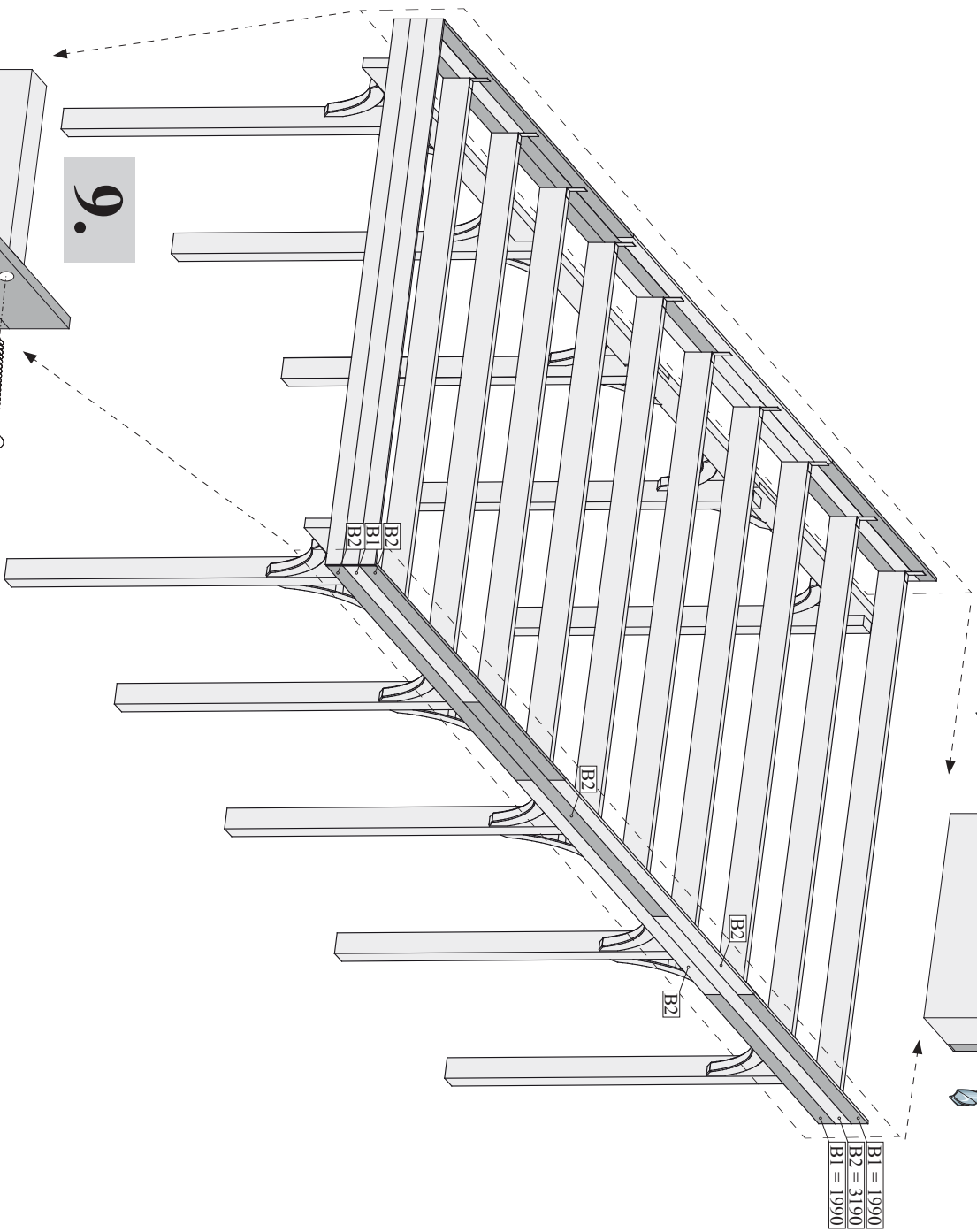
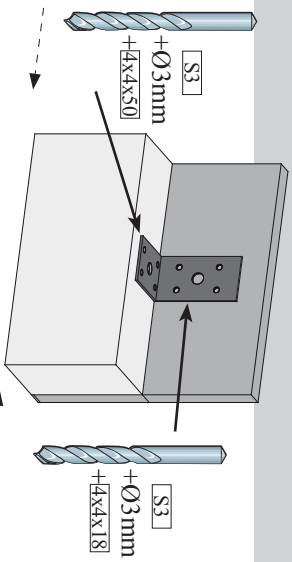
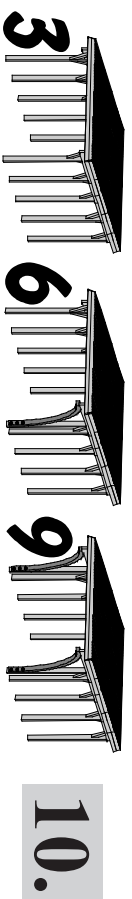

11.

4 5 6 7 8 9

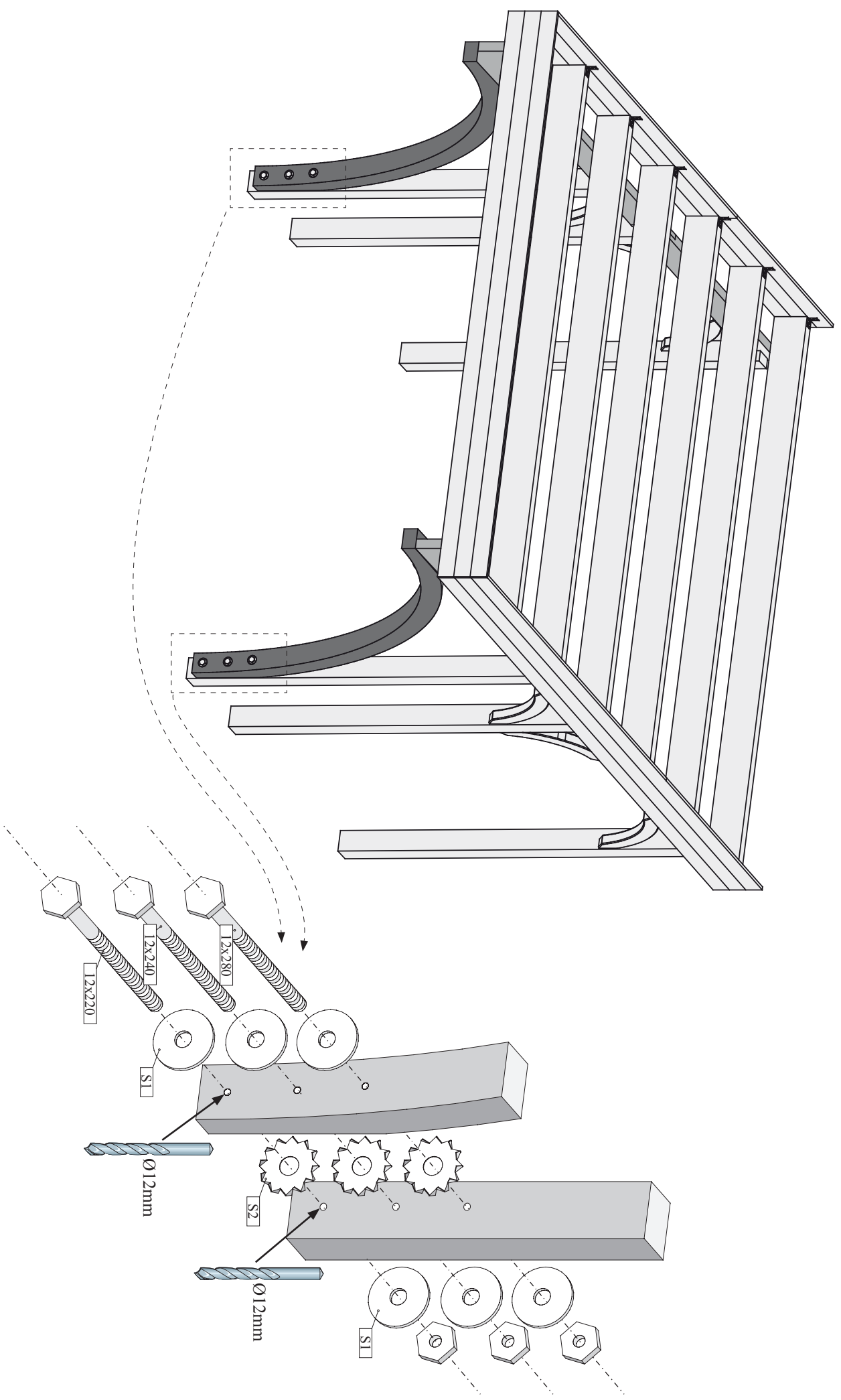

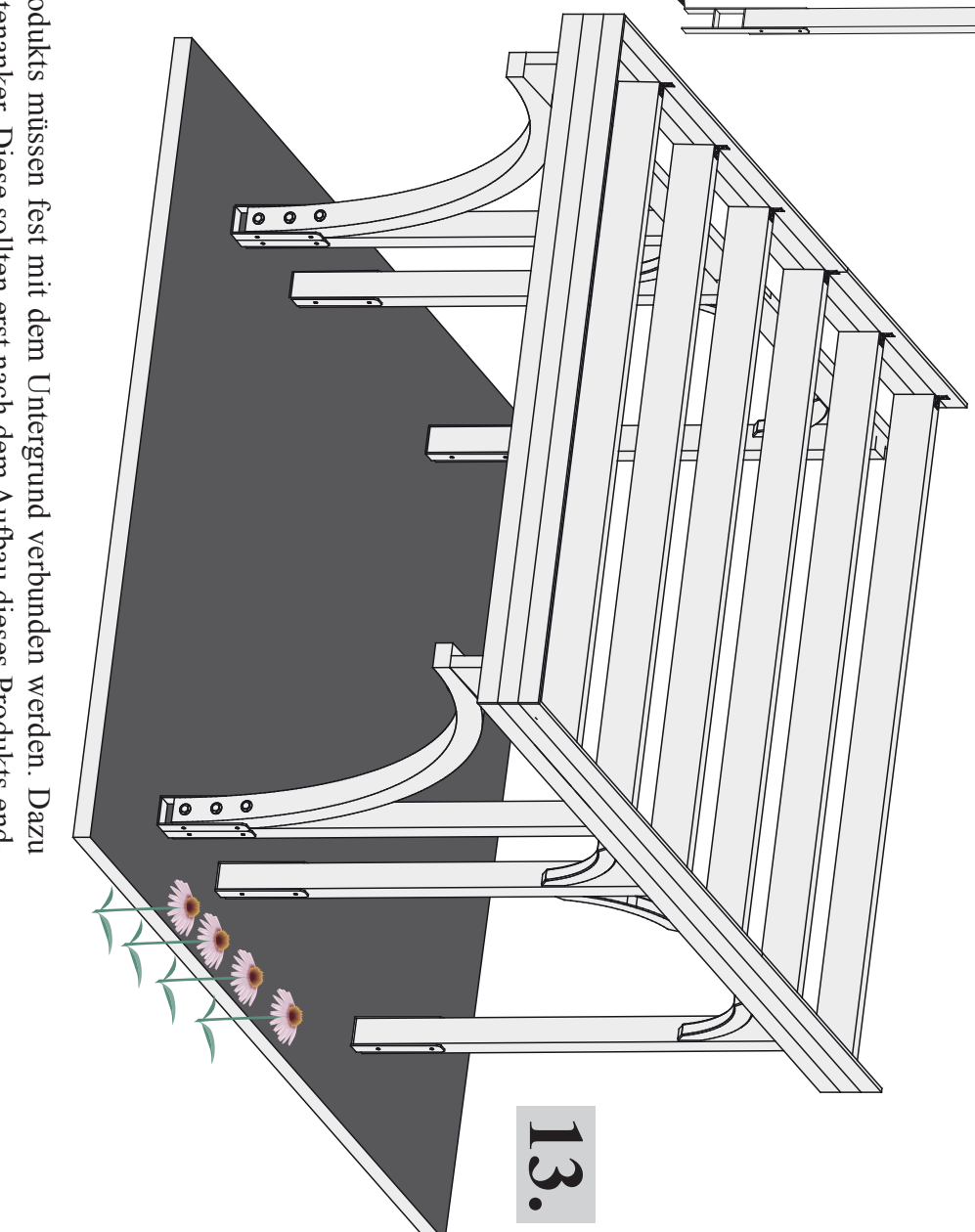
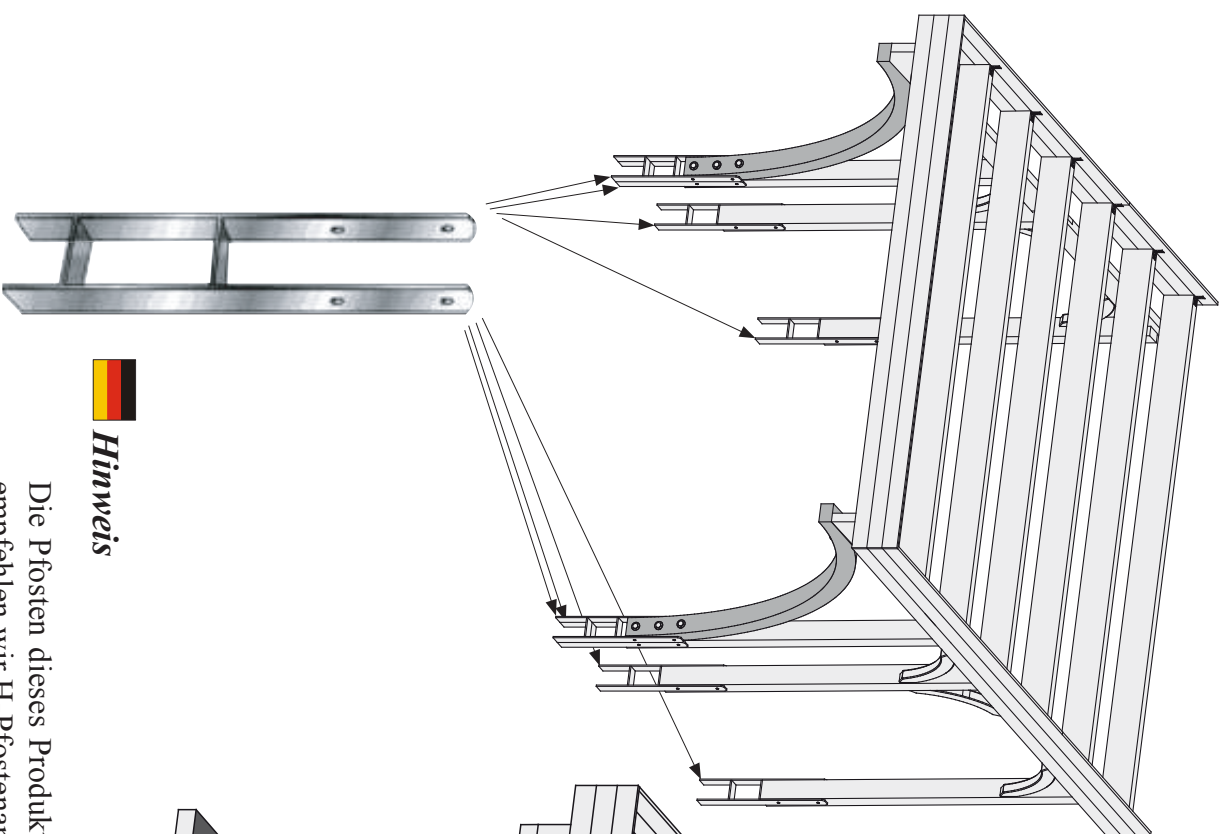

Hinweis

Die Pfosten dieses Produkts müssen fest mit dem Untergrund verbunden werden. Dazu empfehlen wir H-Pfostenanker. Diese sollten erst nach dem Aufbau dieses Produkts endgültig mit Beton versehen werden. Die H-Pfostenanker und das zugehörige Befestigungsmaterial sind nicht im Lieferumfang dieses Produkts enthalten.

14.

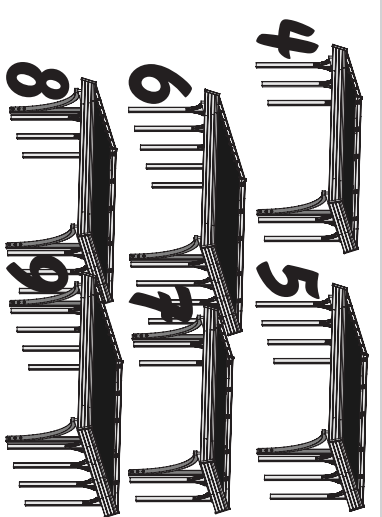
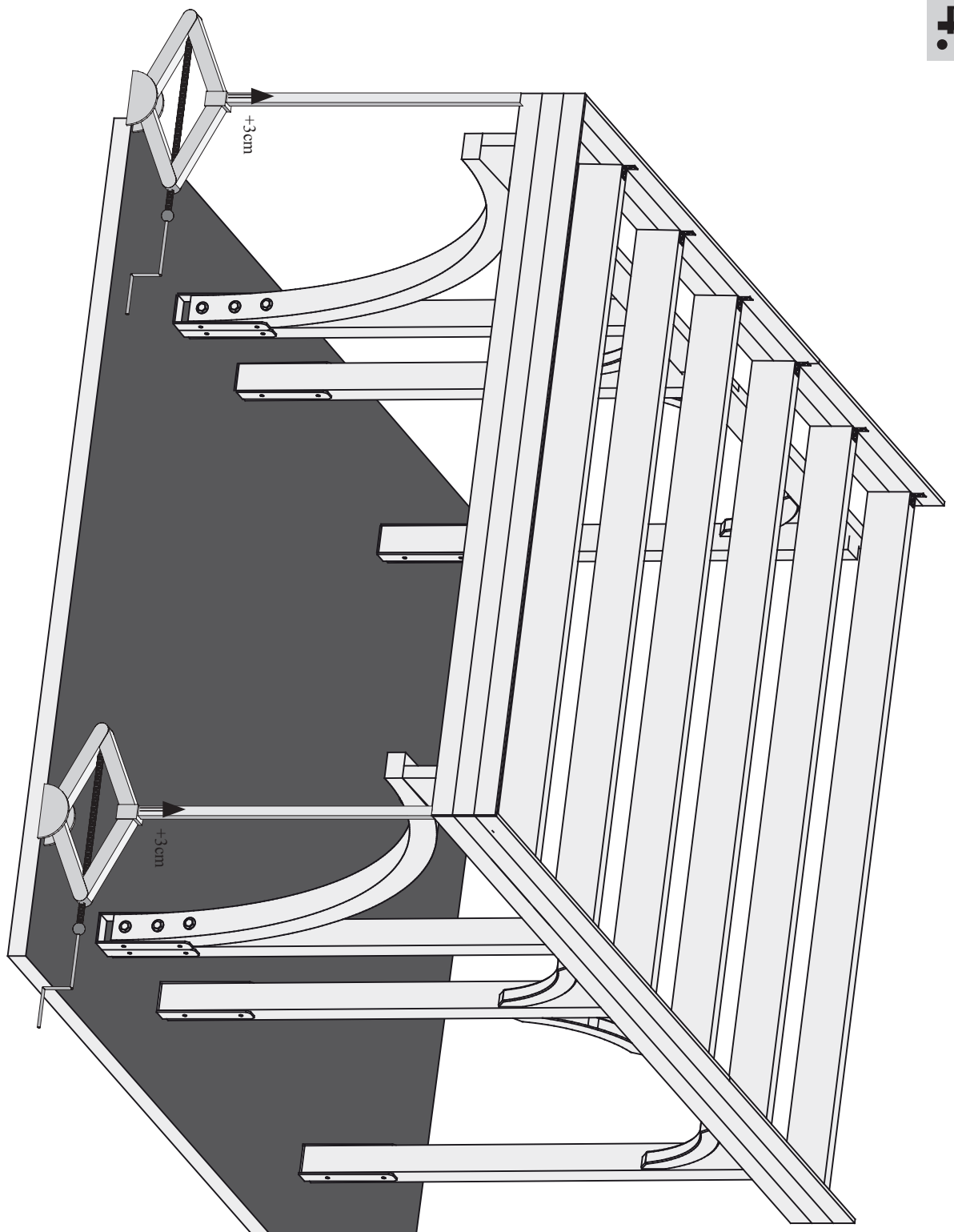

15.

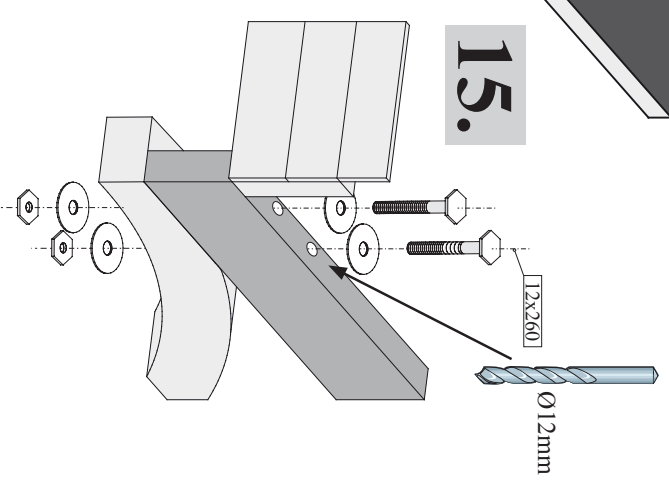

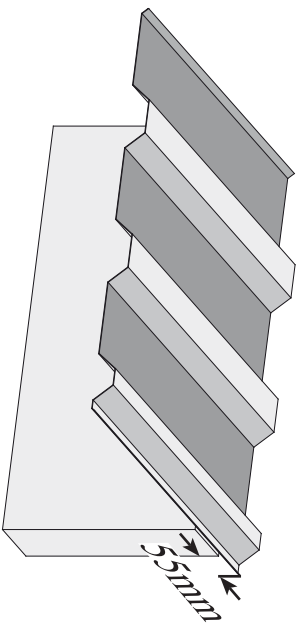
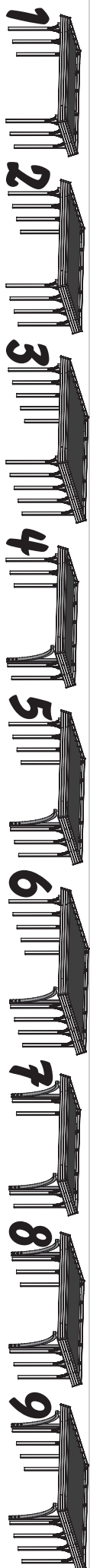

16.

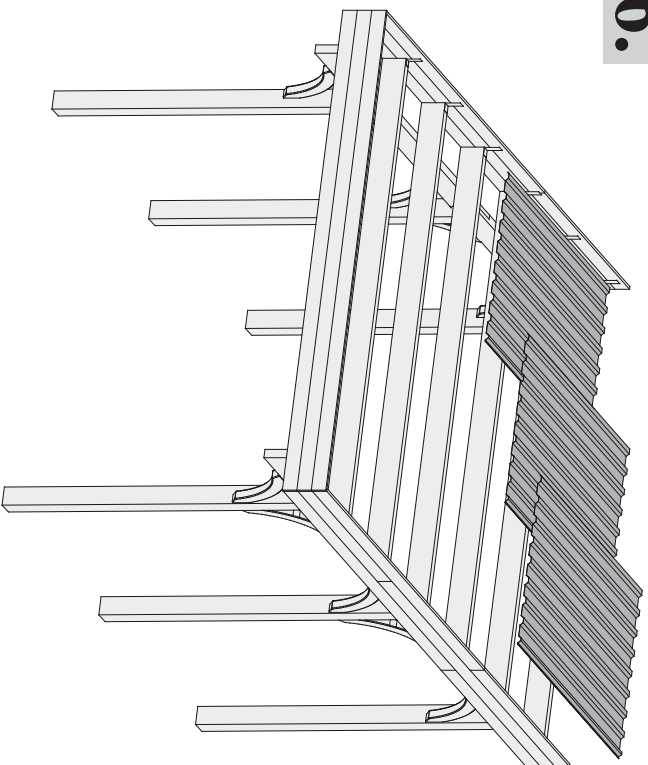

17.

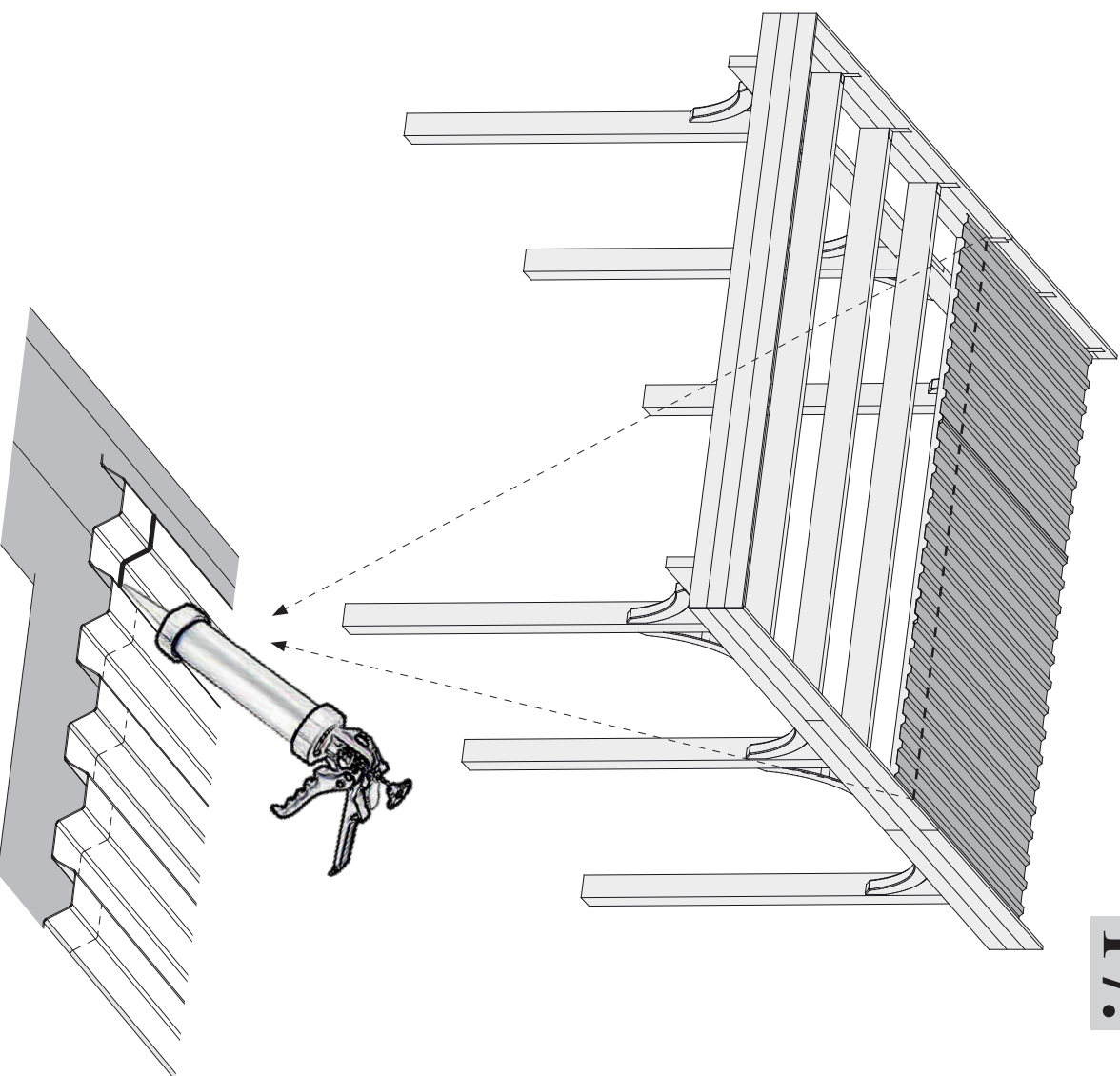

18. 11 4 7

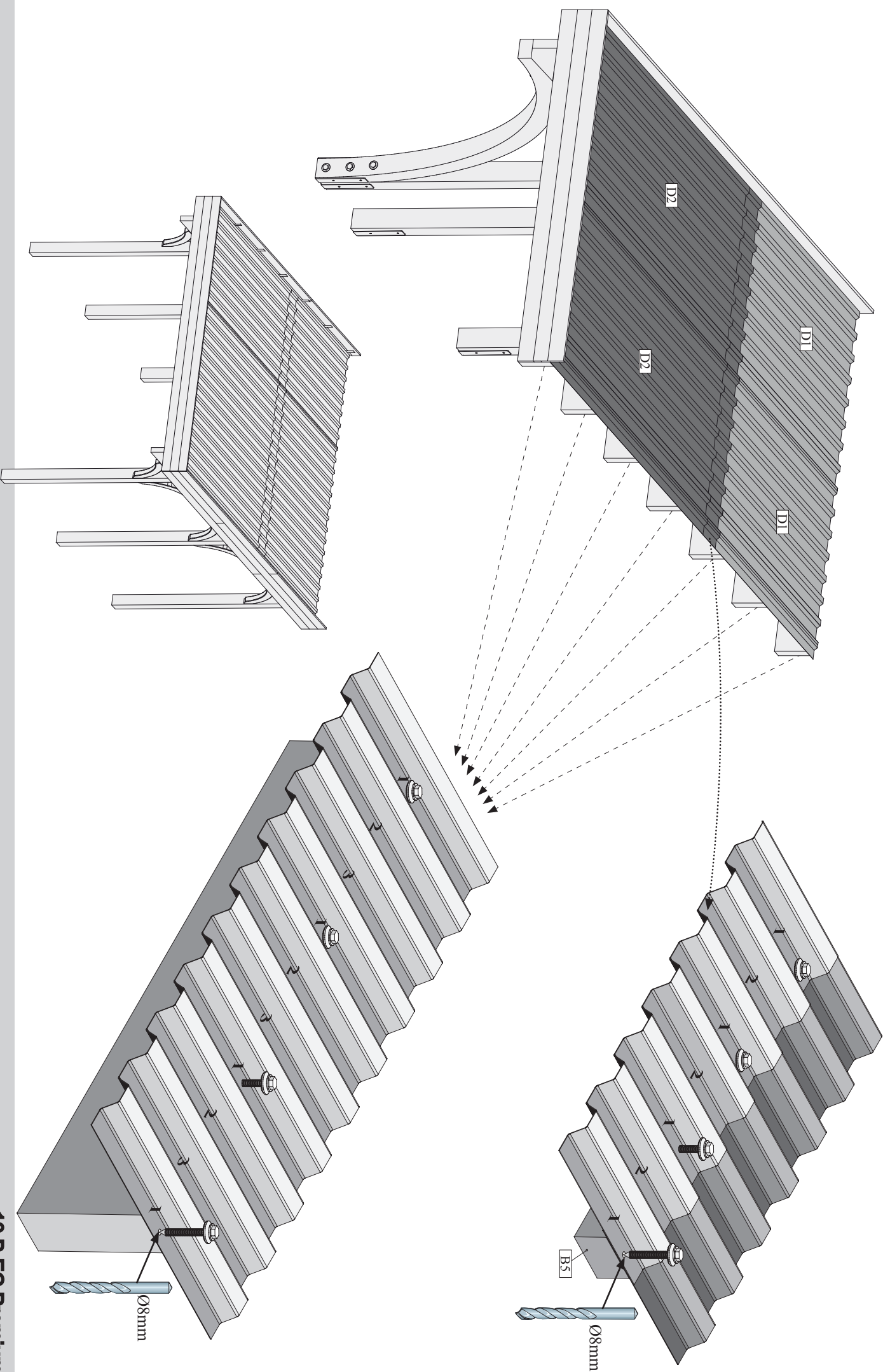

18.

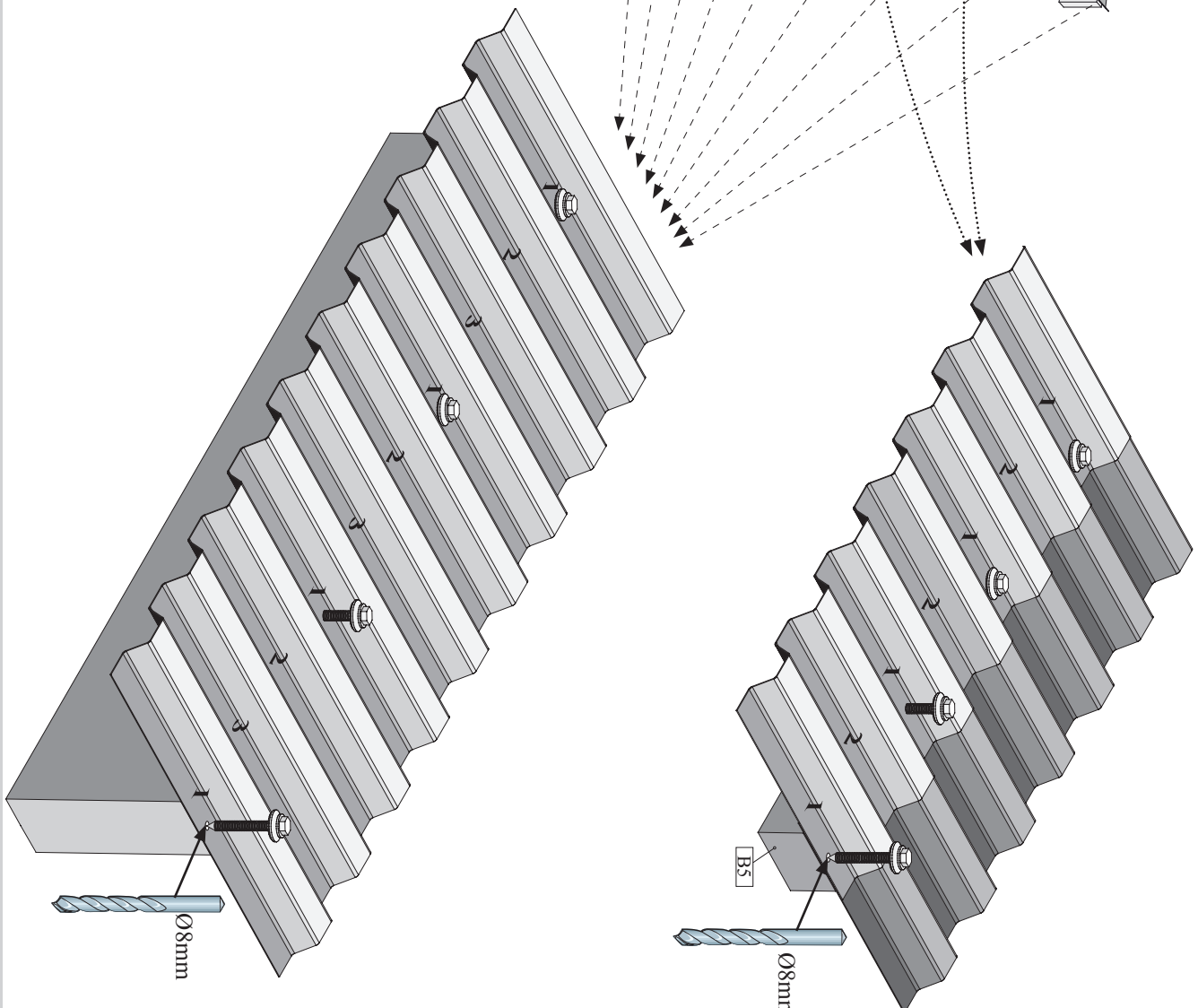
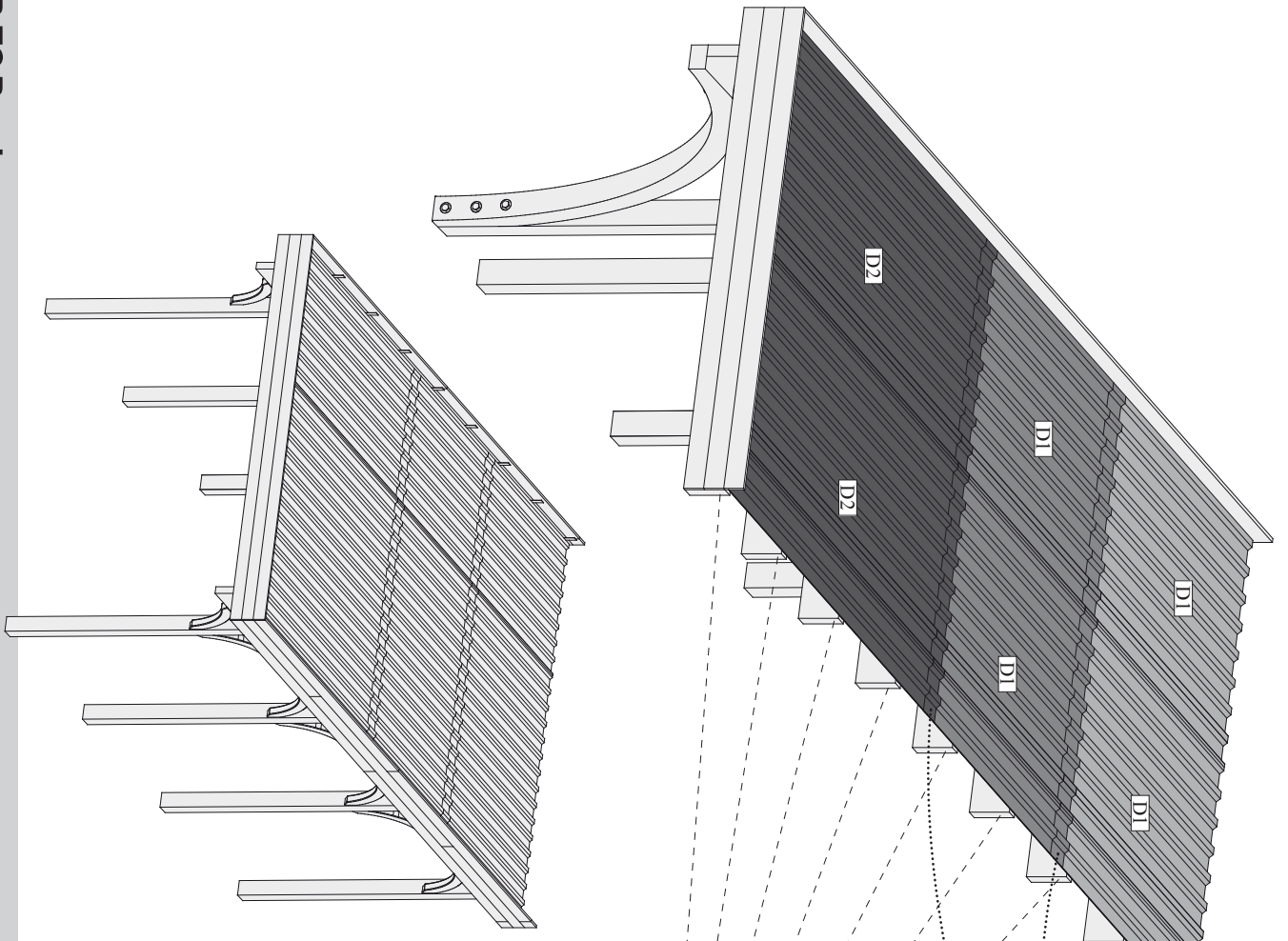
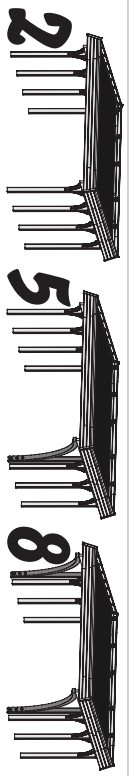

18. 3 6 9

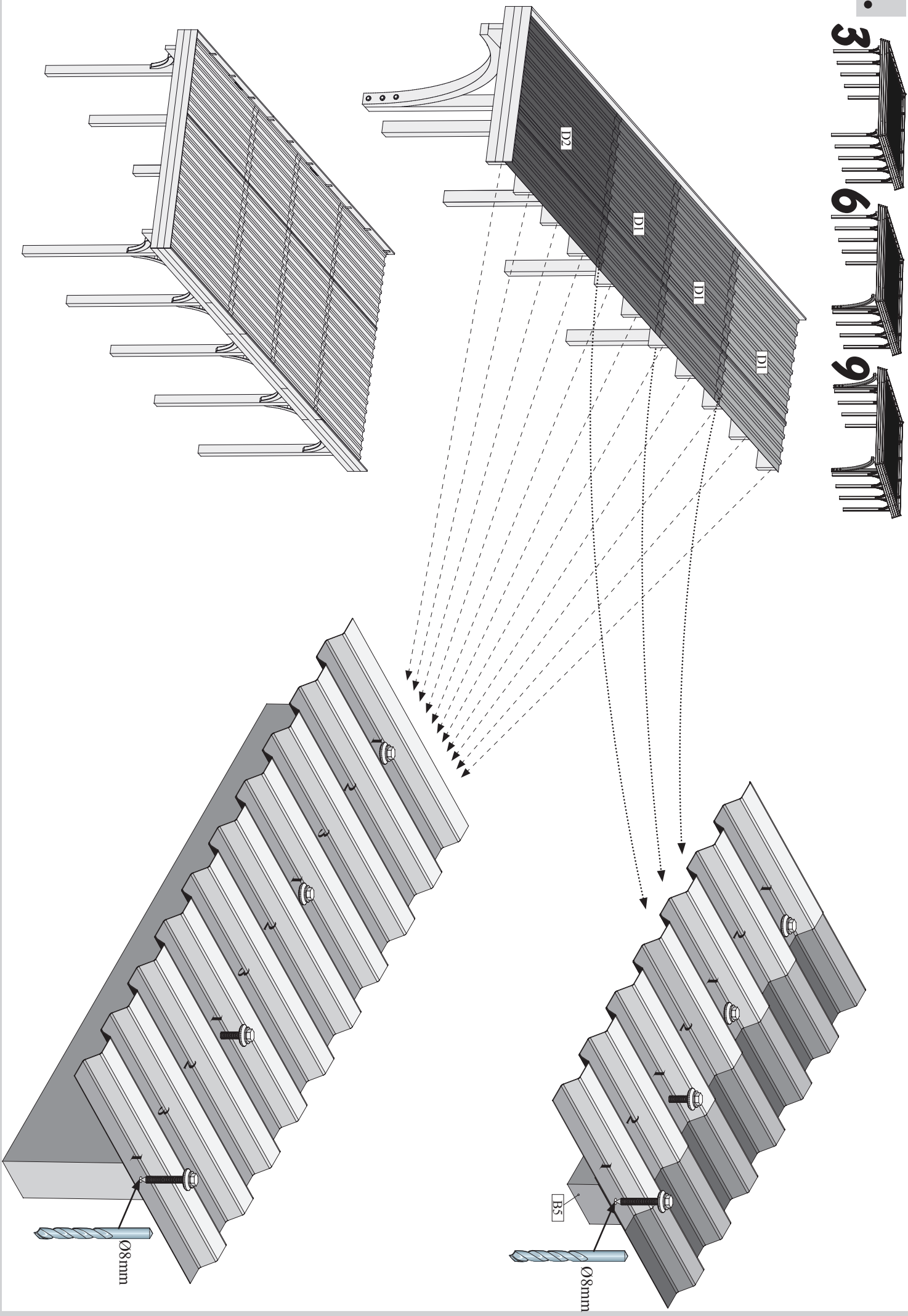

Lagerung

Prüfen Sie genau Ihre gelieferte Ware, spätere Reklamationen können nicht anerkannt werden.

Bitte beachten Sie diese Lagerungs- und Verarbeitungshinweise. Bei Nichteinhalten keine Reklamationsansprüche!

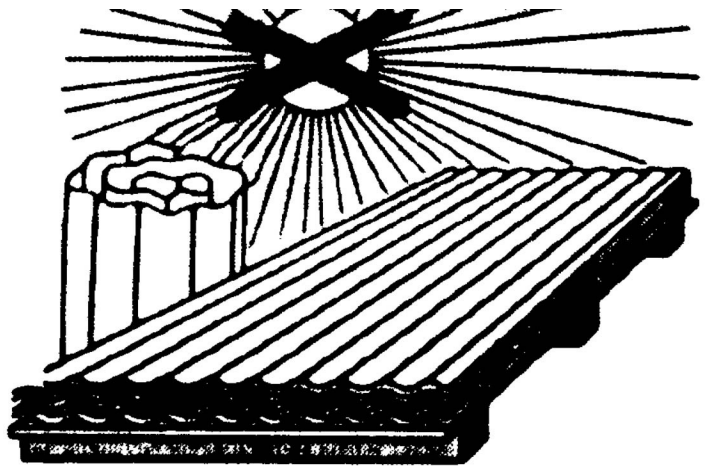

- Hitzestau und Nässe vermeiden.
- PVC-Tafeln dürfen im Stapel nicht dem Sonnenlicht und der Feuchtigkeit ausgesetzt werden. Es besteht Gefahr der Überhitzung (Brennglaswirkung!).
- Die maximale Lagerungstemperatur im Stapel darf 60°C nicht überschreiten. Für Brennglasschäden übernehmen wir keine Haftung.
- Auf ebener, nicht aufgeheizter Unterlage lagern und mit licht- und wasserundurchlässigen hellen Planen abdecken.
- Stapelhöhe max 50 cm
- Max Raumtemperatur: 40°C
- Während der Lagerung müssen PVC-Tafeln von Witterungseinflüssen, Verschmutzung und mechanischen Belastungen geschützt werden.

Montage

- Nicht bei Temperaturen unter 5°C durchführen.
 - Montagebedingte manuelle Transporte einzelner Platten nicht bei Wingschwindigkeit über 3m/s durchführen.
 - Bei der Montage von Doppelstegplatten ist die Wandanschlussseite mit einer Dichtung abzuschließen, sodass das Eindringen von Staub und Regenwasser verhindert wird.
- Aufgrund von verschiedenen Anbauoptionen ist das Dichtband nicht im Lieferumfang enthalten.

Reinigung

- Der Reinigungszyklus ist abhängig vom Verschmutzungsgrad, sollte jedoch von außen mindestens einmal jährlich erfolgen.
- Verschmutzungen mit Wasser oder Haushaltsreinigungsmitteln beseitigen.
- Keine scheuernden, ätzenden oder lösungsmittelhaltigen Zusätze verwenden.

 H-Pfostenanker montieren

 Install concrete anchors

 Anclas concretas instalan

 Ancres de béton installer

 Betonankers installeren

 Ancora di calcestruzzo installano



1. Eine Grube für jeden Pfosten ausheben.
Creusez un trou pour chaque montant.
Dig a hole for each column.
Een put voor elke staander graven.
Cavar un agujero por cada poste.
Creare un foro per ogni montante.



2. Der H-Pfostenanker kann auf dem Brett in seiner Lage noch verändert werden.
Les parties métalliques inférieures des montants peuvent encore être ajustées en fonction de leurs position respective sur les liteaux.
The position of the column joists can be altered due to their position on the plank.
De staanderdraggers kunnen door de positie op de plank qua positie nog veranderd worden.
La posición de los portapostes puede variarse a su posición mediante la posición sobre la tabla.
Le parti metalliche possono essere ancora aggiustate in funzione della loro posizione rispettiva sopra la tavola.



3. Das Holzprodukt aufstellen. Die Pfosten in die H-Pfostenanker stellen. Etwas Abstand zwischen Pfostenende und Metall lassen. Die Pfosten durchbohren um sie mit den H-Pfostenankern zu verschrauben.

Positionnez le pavillon. Placez les montants dans leurs parties métalliques inférieures. Percez les montants afin de pouvoir ensuite les fixer et les visser aux parties inférieures métalliques.

Position the pavilion. Insert the columns into the joists in the process. Drill holes in the columns in order to connect them to the joists by means of screws.

Het paviljoen opstellen. De staanders daarbij in de staanderdraggers stellen. Om de staanders met de dragers vast te schroeven, moeten de staanders doorgeboord worden.

Colocar el pabellón. Colocar los postes en los portapostes. Perforar los postes para poderlos atornillar con los portapostes.

Posizionare il padiglione. Piazzare i montanti nelle loro parti metalliche. Per collegare i montanti con le parti metalliche è necessario perforare i montanti.



4. Eine Maschinenschraube vorsichtig durch die Öffnung des H-Pfostenankers einschlagen bis sie auf der anderen Seite wieder austritt.

Introduisez doucement dans le trou de la partie métallique, à l'aide d'un marteau, une vis d'assemblage à écrou, et cela jusqu'à ce qu'elle apparaisse de l'autre côté.

Carefully drill a drill screw through the opening in the concrete anchor and into the wood until the screw comes out the other side.

Een machineschroef voorzichtig door de opening van het betonanker in het hout inslaan tot ze op de andere zijde naar buiten treedt.

Introducir por percusión cuidadosamente un bulón ordinario en la madera a través de la apertura del anclaje de hormigón hasta que salga por el otro lado. Después aplanar el hormigón.

Introdurre, facendo attenzione, una vite d'assemblaggio nel foro dell'ancora di calcestruzzo nel legno fino a quando essa non fuoriesce dall'altra parte.

 H-Pfostenanker montieren

 Install concrete anchors

 Anclas concretas instalan

 Ancres de béton installer

 Betonankers installeren

 Ancora di calcestruzzo installano



5.
Die Schraube mit Mutter und 2 Unterlegscheiben fixieren.
Vissez et serrez les vis à l'aide de boulons.
Attach nuts to the screws.
De schroeven met moeren fixeren.
Fijar los tornillos con las tuercas.
Fissare le viti con l'aiuto dei bulloni.



6.
Füllen Sie Beton in das ausgegrabene Loch. Der H-Pfostenanker bleibt weiterhin mit der Leiste fixiert. Danach den Beton glattstreichen.
Remplissez les trous creusés à l'aide de béton. Les parties inférieures métalliques des montants doivent encore rester maintenues en place à l'aide des liteaux. Nivelez ensuite le béton.
Fill the holes you have dug with concrete. The concrete anchor remains attached to the slat. Then, smooth out the concrete.
Giet beton in de put. Het betonanker blijft verder met de lijst gefixeerd. Daarna de beton gladmaken.
Llene el agujero cavado con hormigón. El anclaje de hormigón continúa fijado con el listón.
Riempire il foro incavato con del calcestruzzo. L'ancora in calcestruzzo continua a rimanere fissata con il listello. Livellare in seguito il calcestruzzo.



7.
Fertig einbetonierter Pfosten.
Montant installé et bétonné.
The posts are completely set in concrete.
Klaar ingebetonnerde staander.
Poste hormigonado acabado.
Montante installato e gettato nel calcestruzzo.