



Manufactured by:
Backyard Discovery
3305 Airport Drive
Pittsburg, KS 66762
800-856-4445

14' X 10' PERGOLA MODEL: # 1802513

BOOKLET INCLUDES:

- *Owner's Manual*
- *Frequently Asked Questions*
- *Assembly Instructions*
- *Warranty Information*

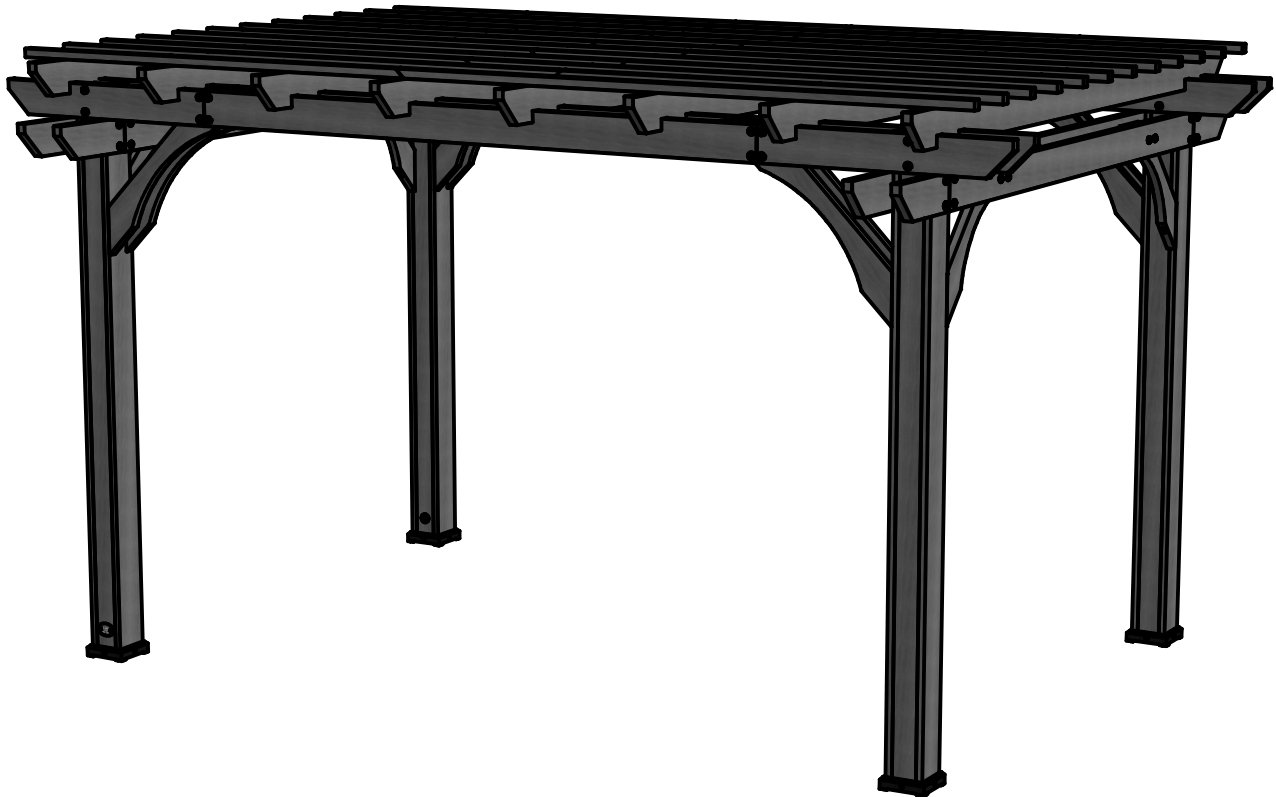

For the most up to date assembly manual,
to register your product or to order replacement parts please visit
www.backyarddiscovery.com

*Save this assembly manual for future reference in the event that
you need to order replacement parts.*

Before you begin

FOR QUICK & EASY
3D ASSEMBLY
INSTRUCTIONS

DOWNLOAD THE FREE APP

BILT.[®]
Intelligent Instructions



GOCONFIGURE
Putting it all together for you

**INSTALLATION
SERVICES
AVAILABLE!***

Need a Helping Hand?
Let our team of professionals
handle the installation for you!

GOCONFIGURE
888-888-5424

*Installation services are only available
to U.S. customers.

Para obtener instrucciones en español, visite www.backyarddiscovery.com

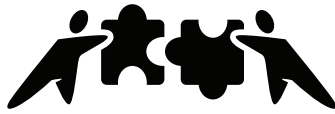

GOCONFIGURE
Putting it all together for you

INSTALLATION SERVICES AVAILABLE!*

Need a Helping Hand?
Let our team of professionals
handle the installation for you!

GOCONFIGURE
888-888-5424

With Go Configure, we bring you 18 years of experience right to your doorstep. We service a wide array of indoor and outdoor recreation products that most consumers don't have the time or ability to deliver & install themselves.

We do the heavy lifting, so you don't have to!

-
- 18+ Years of Experience Servicing Big Box Retailers and Direct Consumers
 - Highly Skilled, Specialized, Courteous, Professional Service Technicians
 - Over 140,000 Installations Annually
 - White Glove Service
 - Satisfaction Guarantee
 - Flexible Appointments, including weekends
 - Coverage across the nation
- Visit www.goconfigure.com for more info!*
-

**Installation services are only available to U.S. customers.*



**PLEASE READ THIS BEFORE STARTING ASSEMBLY
LEA ESTO ANTES DE COMENZAR CON EL ENSAMBLAJE**

- READ THE ASSEMBLY MANUAL COMPLETELY, PAYING SPECIAL ATTENTION TO THE IMPORTANT TIPS AND SAFETY INFORMATION.
- AFTER YOU HAVE READ THE ASSEMBLY MANUAL, YOU WILL BE ABLE TO DECIDE IF YOU NEED PROFESSIONAL HELP TO COMPLETE THE ASSEMBLY OF THE STRUCTURE.
- SEPARATE AND IDENTIFY ALL PARTS TO MAKE SURE THAT YOU HAVE ALL OF THE PARTS LISTED.
- IF YOU CAN'T FIND ALL OF THE PARTS, CHECK THE PACKING MATERIAL. SMALL PARTS MAY HAVE FALLEN INTO IT DURING SHIPMENT.
- IF YOU HAVE PROBLEMS WITH THE ASSEMBLY OR IF ANY PART IS MISSING OR DAMAGED, PLEASE CALL THE HELP LINE **1-800-856-4445 OR VISIT www.backyarddiscovery.com**
-
- LEA ESTE MANUAL DE ENSAMBLAJE COMPLETAMENTE, Y PONGA ATENCIÓN ESPECIAL A LOS CONSEJOS IMPORTANTES Y A LA INFORMACIÓN DE SEGURIDAD.
- DESPUÉS DE HABER LEÍDO EL MANUAL DE ENSAMBLAJE, PODRÁ DECIDIR SI NECESITA AYUDA PROFESIONAL PARA AYUDARLE A TERMINAR DE ENSAMBLAR LA ESTRUCTURA.
- SEPARE E IDENTIFIQUE TODAS LAS PIEZAS PARA ASEGURARSE DE QUE TENGA TODAS LAS PIEZAS ENUMERADAS.
- SI NO PUEDE ENCONTRAR TODAS LAS PIEZAS, REVISE EL MATERIAL DE EMPAQUE. LAS PIEZAS PEQUEÑAS PUEDEN HABERSE CAÍDO DURANTE EL ENVÍO.
- MANTÉNGASE ALEJADO DE LOS NIÑOS MENORES A LA EDAD RECOMENDADA.
- SI TIENE PROBLEMAS CON EL ENSAMBLAJE, O SI ALGUNA PIEZA FALTA O ESTÁ DAÑADA, LLAME A LA LÍNEA DE AYUDA AL **1-800-856-4445 O VISITE www.backyarddiscovery.com**

PLEASE HAVE THE FOLLOWING INFORMATION WHEN YOU MAKE YOUR CALL:

- 1 – MODEL NUMBER OF THE PRODUCT LOCATED ON THE FRONT OF THE ASSEMBLY MANUAL
- 2 – DESCRIPTION OF THE PART FROM THE PARTS LIST

CUANDO LLAME, TENGA LA SIGUIENTE INFORMACIÓN A LA MANO:

- 1 - NÚMERO DE MODELO DEL PRODUCTO, QUE SE ENCUENTRA EN EL FRENTE DEL MANUAL DE ENSAMBLAJE.
- 2 - DESCRIPCIÓN DE LA PIEZA, SEGÚN SE ENCUENTRA EN LA LISTA DE PIEZAS

Owner's Manual Outdoor Product

Dear Customer:

Please read entire booklet completely before beginning the assembly process.

Structures are **not intended for public use**. The Company does not warranty any of its residential structures subjected to commercial use such as: Recreational Park, or any similar Commercial Application.

Please follow all recommendations below. **Failure to do so may result in the warranty being void and/or safety violations that could result in serious injury.** This manual contains helpful information concerning Assembly Preparation, Installation Procedure, and Required Maintenance. Always keep safety in mind as your structure is being built.

PLEASE RETAIN THESE INSTRUCTIONS FOR FUTURE REFERENCE. KEEP THEM IN A SAFE PLACE WHERE YOU CAN REFER TO THEM AS NEEDED. IN ORDER TO PROVIDE YOU WITH THE MOST EFFICIENT SERVICE, IT IS REQUIRED THAT YOU PROVIDE US WITH THE PART NUMBERS WHEN ORDERING PARTS.

For Your Records:

Please take time and fill out the information below. This information will be needed for warranty issues.

Where Purchased: _____

Date of Purchase: _____

Installation Date: _____

Installed by: _____

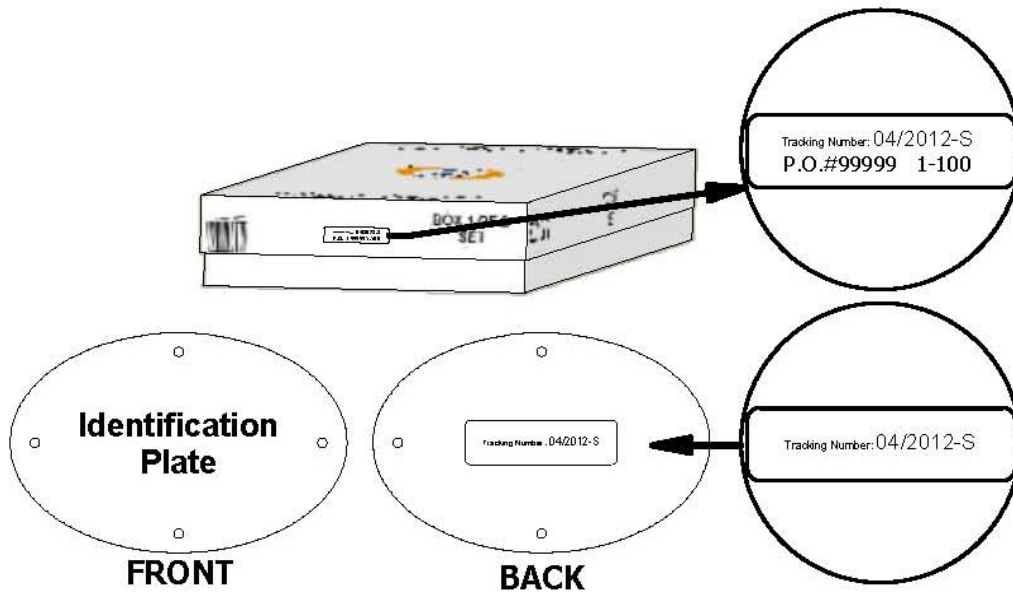

Tracking Number Reference Label

Tracking ID number on the carton and back of the ID plate are included for tracking purposes associated with warranty claims.

Owner's Manual Outdoor Product

Maintenance Instructions:

1. Check all nuts and bolts twice monthly during the usage season and tighten as required. (But not so tight that you crack the wood) It is particularly important that this procedure be followed at the beginning of each season.
2. Oil all metallic moving parts monthly during the usage period.
3. Check all coverings for bolts and sharp edges twice monthly during usage season to be certain they are in place. Replace when necessary. It is especially important to do this at the beginning of each new season.
4. For rusted areas on metallic members such as hinges, brackets, etc. sand and repaint, using a non lead-based paint meeting the requirements of Title 16 CRF Part 1303.
5. Inspect wood parts monthly. The grain of the wood sometimes will lift in the dry season causing splinters to appear. Light sanding may be necessary to maintain a safe environment. Treating your Product with protection (sealant) after sanding will help prevent severe checking/splitting and other weather damage.
6. We have applied a waterborne translucent stain to your unit. This is done for color only. Once or twice a year, depending on your climate conditions, you must apply some type of protection (sealant) to the wood of your unit. Prior to the application of sealant, lightly sand any "rough" spots on your set. Please note this is a requirement of your warranty.

Outdoor Product Assembly Manual FAQs:

- 1. Is the wood treated with chemicals? Backyard Discovery uses 100% Chinese Cedar wood which is naturally bug resistant, decay and rot resistant. To help ensure your family's safety, our wood is completely chemical free and we do not use pressure-treated wood. The stain we use is a top coat using a water-based product that is for appearance only.*
- 2. How often should the product be stained? Backyard Discovery recommends the product be stained once each year. A water or oil based stain can be used at the customer's discretion.*
- 3. Why does it seem that my product is developing cracks? Wood is a natural material; no two pieces are exactly alike. Each piece has its own characteristics and personality and reacts differently to environmental changes. When any wood product is exposed to the elements, it develops "wood checks". A check is the radial separation of the wood fibers running with the grain of the wood. These are caused by the varying temperature and moisture conditions. A check is not a crack – it does not affect the strength or durability of the wood or structural integrity of the product.*
- 4. Do Backyard Discovery products come with a warranty? Yes. All Backyard Discovery products carry a 1-year replacement warranty on all parts for manufacturer's defect. Our wood carries a 5 year pro-rated warranty on rot and decay as well. Please see warranty details for more information.*
- 5. What is the best way to get started assembling the product? Backyard Discovery recommends taking all the parts out of the boxes and arranging them by part number before you begin any assembly. This will not only allow faster assembly, but will also identify any parts that may be missing or damaged so they can be replaced before assembly. If parts are missing or need replacement, go to www.backyarddiscovery.com/support.aspx and follow the prompts to order them. Next, read the assembly manual and get the tools ready for the job as recommended in the manual. If the assembly manual is lost or misplaced a new one can be printed from Backyard Discovery's website: www.backyarddiscovery.com .*
- 6. The 2"x4" boards do not measure 2"x 4". Why not? In the U.S. it is common practice to describe lumber dimensions using the rough cut sizes from the saw mill and not the finished dimensions. Retailers, home stores, etc. all use this accepted practice for describing lumber dimensions. However, Backyard Discovery products are designed and constructed using the actual dimensions so everything fits properly and remains so during the life of the product.*

For more information and frequently asked questions, please refer to our website at www.backyarddiscovery.com .

Tools Required for Installation:

(These are the tools that are generally required for assembly of our outdoor products. These tools are not included with the outdoor product purchase.)

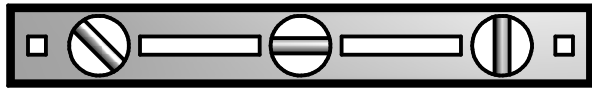

(Level 24")

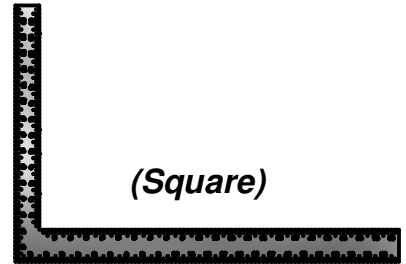

(Square)



(Tape Measure)



(Phillips Screw Driver)



(Rubber Mallet - Optional)

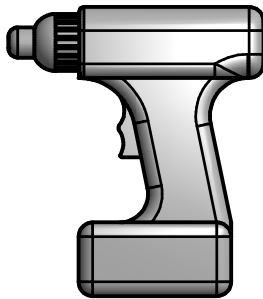

(Cordless Drill or Electric Drill)

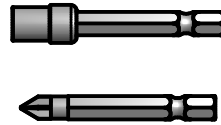

(Drill Attachments: Phillips Head & Socket Driver)

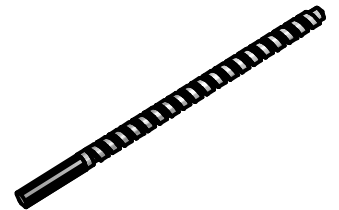

(3/16" Concrete Drill Bit)



(An Adult w/ an Adult Helper)



(Ladder)

Basic Setup Dimensions

Place the set on level ground, not less than 6 ft [2 m] from any structure or obstruction such as a fence, garage, house, overhanging branches, laundry lines, or electrical wires.

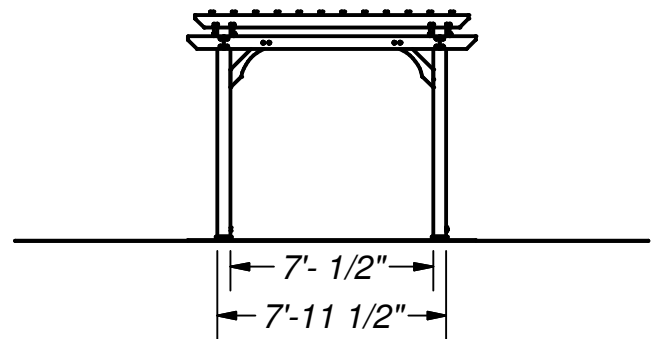
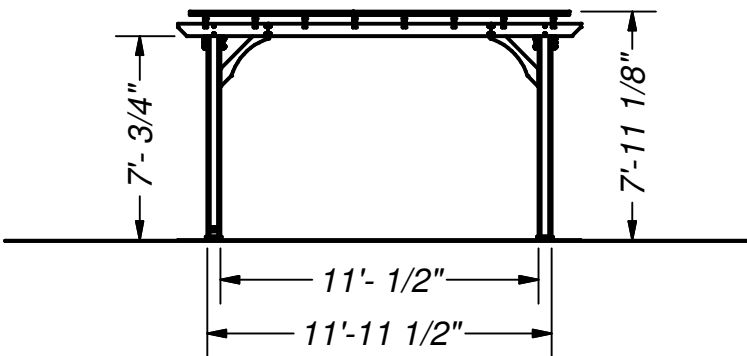
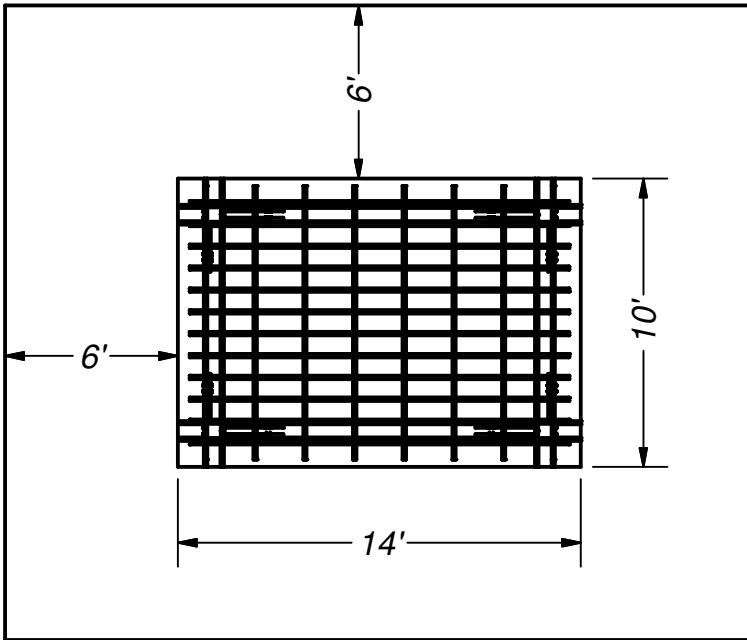

Important Assembly Notes

- 1) While assembling unit, take time before and after each phase to make sure unit is level. If unit is not level, assembly will be difficult and improper assembly may result. Extra care must be taken to ensure the unit is square.
- 2) Pay close attention to the **ITEMS NEEDED FOR EACH PHASE**. They can be a valuable aid when sorting your wood and hardware. Assembly will be made easier if items are sorted by phase.
- 3) Pay close attention to make sure you are using the correct hardware in the correct phases. Using incorrect hardware may result in improper assembly.
- 4) Whenever a T-nut is used, follow these directions. Place T-nut in pre-drilled hole. Tap in with hammer. Place bolt with washers in the opposite side. Hand tighten to make sure the bolt is in the T-nut. **DO NOT** over tighten.
- 5) Read the steps of each phase thoroughly. The written steps may include important information not shown in the illustrations.

Parts Identification

Wood Components

(NOT TO SCALE)



- (2) **D1 - JOIST - W4L11635**
1 3/8"x5 1/4"x92 7/8" (36x134x2360)

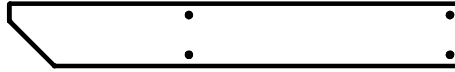

- (4) **D2 - JOIST END - W4L11643**
1 3/8"x5 1/4"x37 1/2" (36x134x954)



- (8) **D3 - SLOTTED JOIST - W4L11637**
1 3/8"x5 1/4"x114" (36x134x2896)



- (2) **D4 - JOIST - W4L11636**
1 3/8"x5 1/4"x90" (36x134x2286)



- (2) **D5 - JOIST - W4L11638**
1 3/8"x5 1/4"x90" (36x134x2286)



- (8) **D6 - JOIST END - W4L11633**
1 3/8"x5 1/4"x15" (36x134x381)



- (4) **D7 - JOIST END - W4L11634**
1 3/8"x5 1/4"x37 1/2" (36x134x954)



- (8) **D8 - LONG ANGLE BRACE - W4L11641**
1 3/8"x5 1/4"x37 1/8" (36x134x942)



- (4) **D9 - SHORT ANGLE BRACE - W4L11642**
1 3/8"x5 1/4"x29 3/4" (36x134x755)

Parts Identification

Wood Components

(NOT TO SCALE)



(2) **D11 - JOIST - W4L11646**
1 3/8"x5 1/4"x92 7/8" (36x134x2360)



(12) **P1 - PURLIN - W4L11639**
1 3/8"x1 3/8"x69 5/8" (36x36x1767)



(12) **P2 - PURLIN - W4L11640**
1 3/8"x1 3/8"x90 1/4" (36x36x2291)

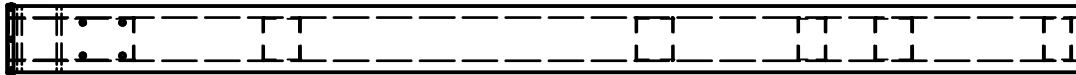

(4) **WP1 - PERGOLA POST - W2A02600**
5 1/2"x5 1/2"x89 1/2" (140x140x2273)

Parts Identification

Hardware

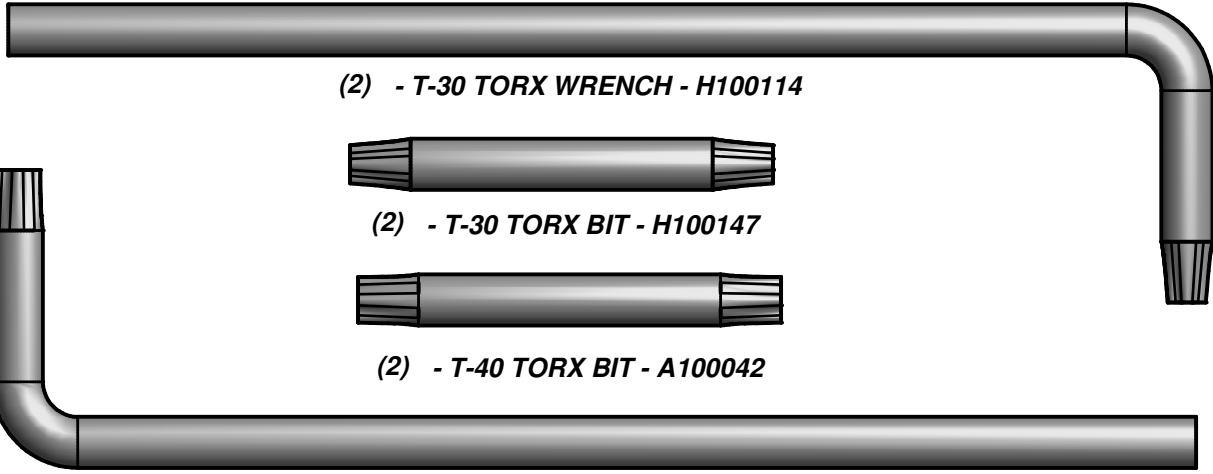

(2) - T-30 TORX WRENCH - H100114



(2) - T-30 TORX BIT - H100147



(2) - T-40 TORX BIT - A100042

(2) - T-40 TORX WRENCH - A100041



(26) - BOLT WH 5/16x7-1/4 BLK - H100196



(42) - BOLT WH 5/16x2-1/4 BLK - H100205

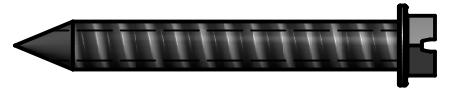

(18) - CONCRETE ANCHOR 1/4" x 2" - H100120



(100) - SCREW PFH 8x2-1/2 BLK - H100201



(17) - SCREW PFH 8x1-1/2 BLK - H100200



(2) - SCREW PFH 8x1/2 BLK - H100203



(2) - SCREW PWH 8x5/8 BLK - H100202

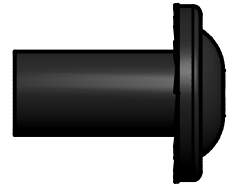

(42) - NUT BARREL WH 5/16x7/8 BLK - H100192



(26) - NUT BARREL WH 5/16x1-1/2 BLK - H100193

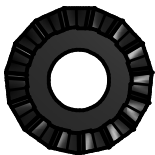

(96) - WASHER LOCK EXT 8x19 BLK - H100198



(13) - LAG SCREW WH 5/16x3 BLK - H100206

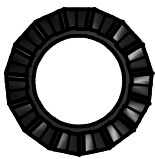

(68) - WASHER LOCK EXT 12x19 BLK - H100199



(18) - LAG SCREW WH 5/16x5-1/2 BLK - H100204

Parts Identification

Accessories
(NOT TO SCALE)

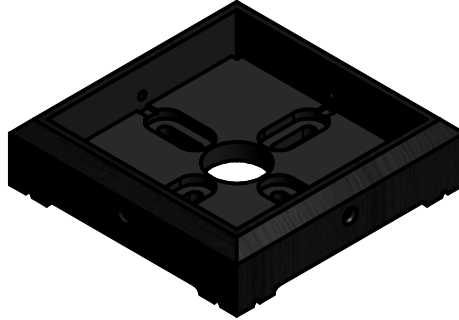

(4) HT - FOOT 142 SQUARE POST - A100029



(1) XR - BYD ID TAG (SMALL) WITHOUT AGES - A100241



(1) - STAIN MARKER - A6P00171



(1) SQ - "A" REVISION TAG - A100314



(2) **D4 - JOIST - W4L11636**
1 3/8"x5 1/4"x90" (36x134x2286)



(4) **D9 - SHORT ANGLE BRACE - W4L11642**
1 3/8"x5 1/4"x29 3/4" (36x134x755)

STEP 1

BUILD BOTH SIDES

*****HAND TIGHEN ONLY AT THIS TIME*****

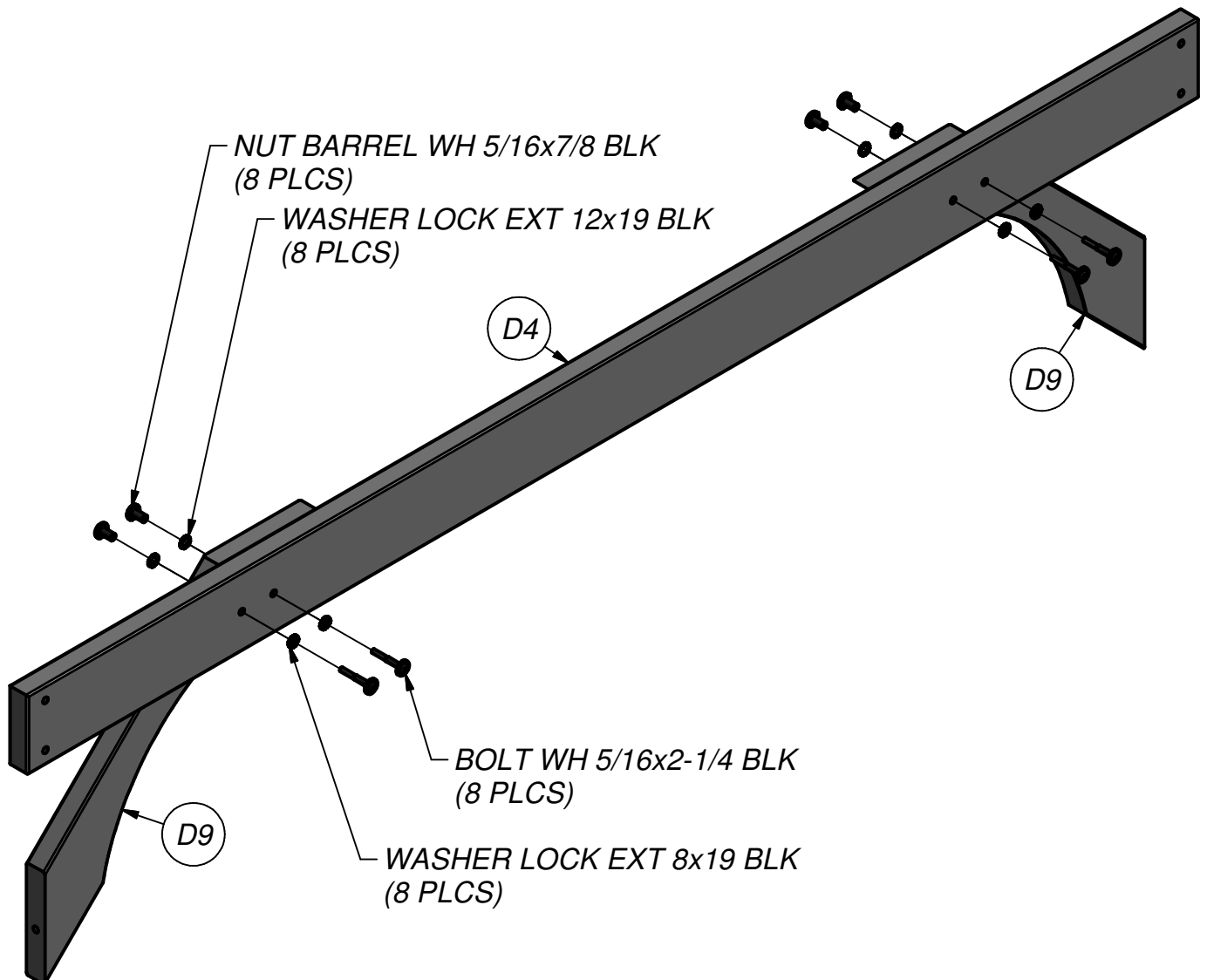
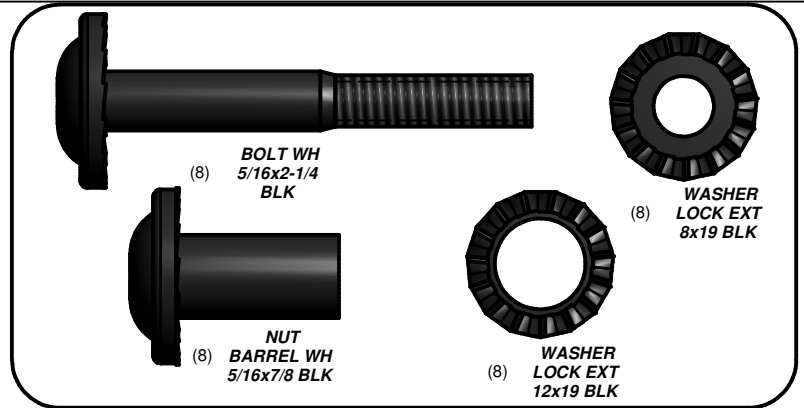



(2) **D11 - JOIST - W4L11646**
1 3/8"x5 1/4"x92 7/8" (36x134x2360)



(4) **D2 - JOIST END - W4L11643**
1 3/8"x5 1/4"x37 1/2" (36x134x954)



(4) **D8 - LONG ANGLE BRACE - W4L11641**
1 3/8"x5 1/4"x37 1/8" (36x134x942)

STEP 2

BUILD BOTH SIDES

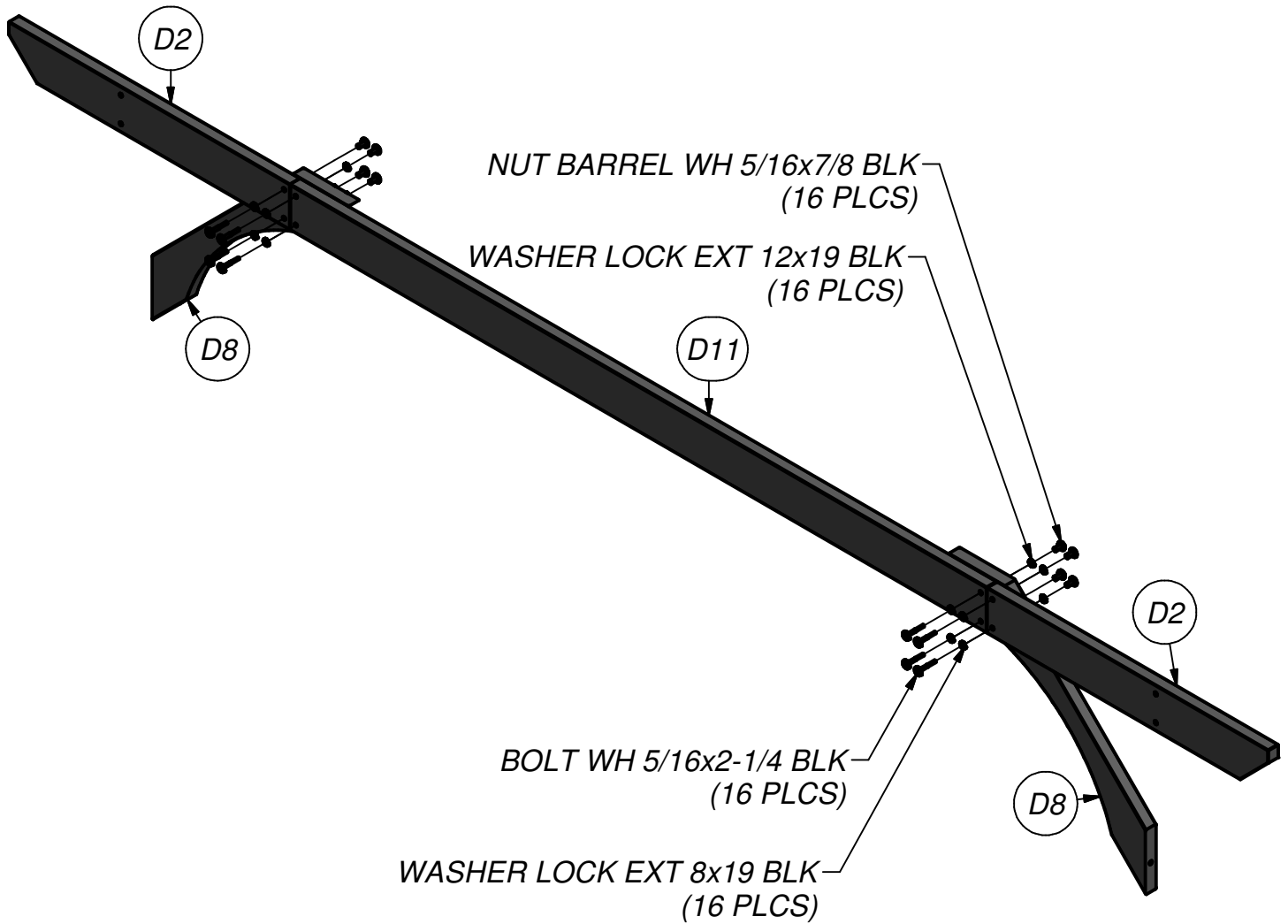
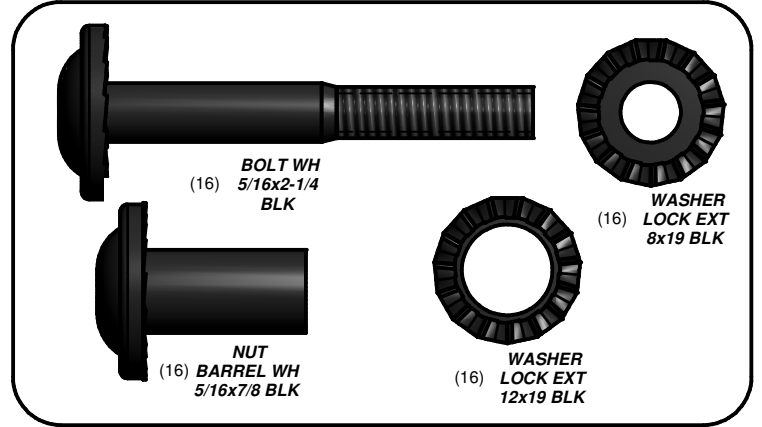



(2) **D1 - JOIST - W4L11635**
1 3/8"x5 1/4"x92 7/8" (36x134x2360)



(4) **D7 - JOIST END - W4L11634**
1 3/8"x5 1/4"x37 1/2" (36x134x954)



(4) **D8 - LONG ANGLE BRACE - W4L11641**
1 3/8"x5 1/4"x37 1/8" (36x134x942)

STEP 3

BUILD BOTH SIDES

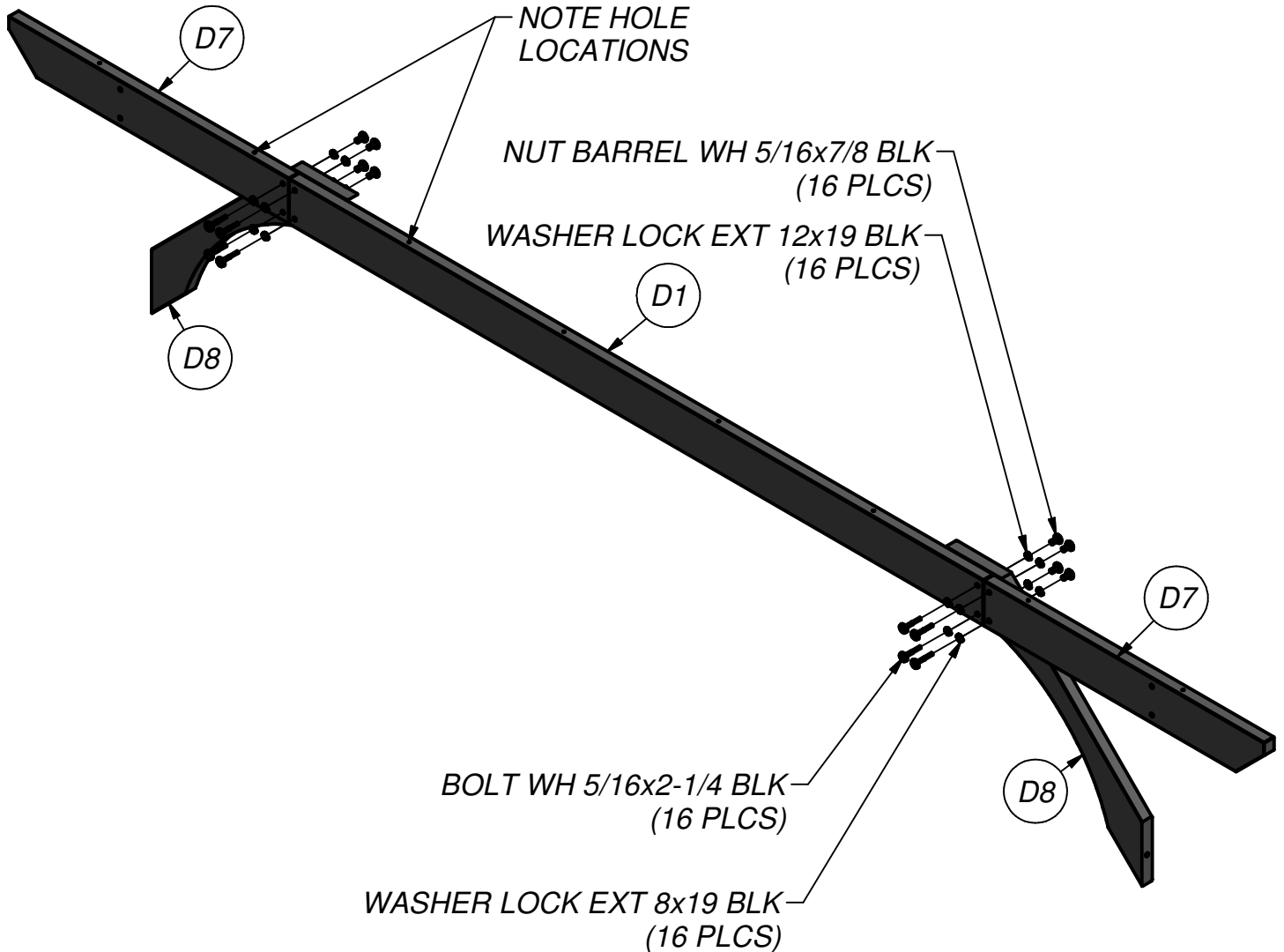
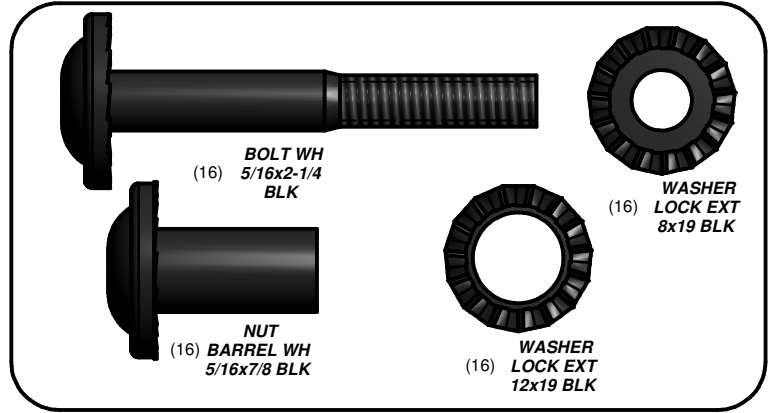



(2) **D5 - JOIST - W4L11638**
1 3/8"x5 1/4"x90" (36x134x2286)

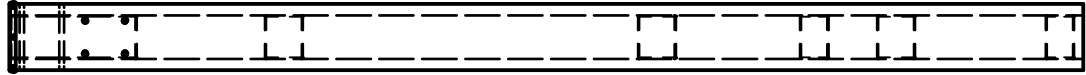

(4) **WP1 - PERGOLA POST - W2A02600**
5 1/2"x5 1/2"x89 1/2" (140x140x2273)

STEP 4

BUILD BOTH SIDES

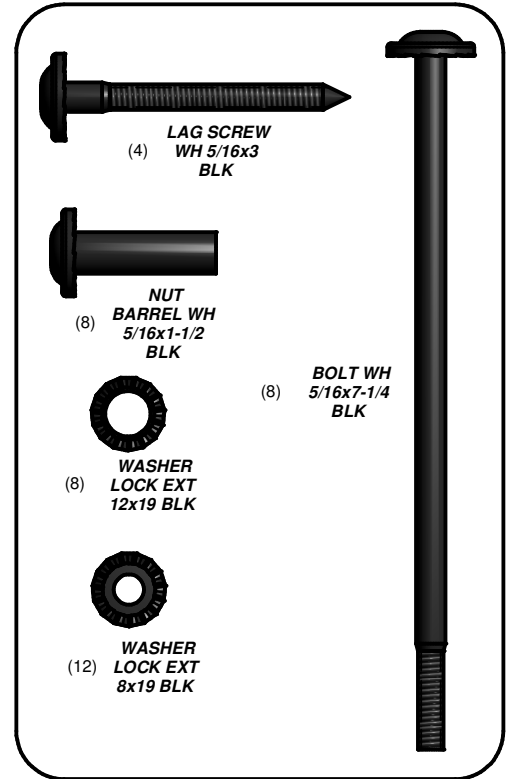
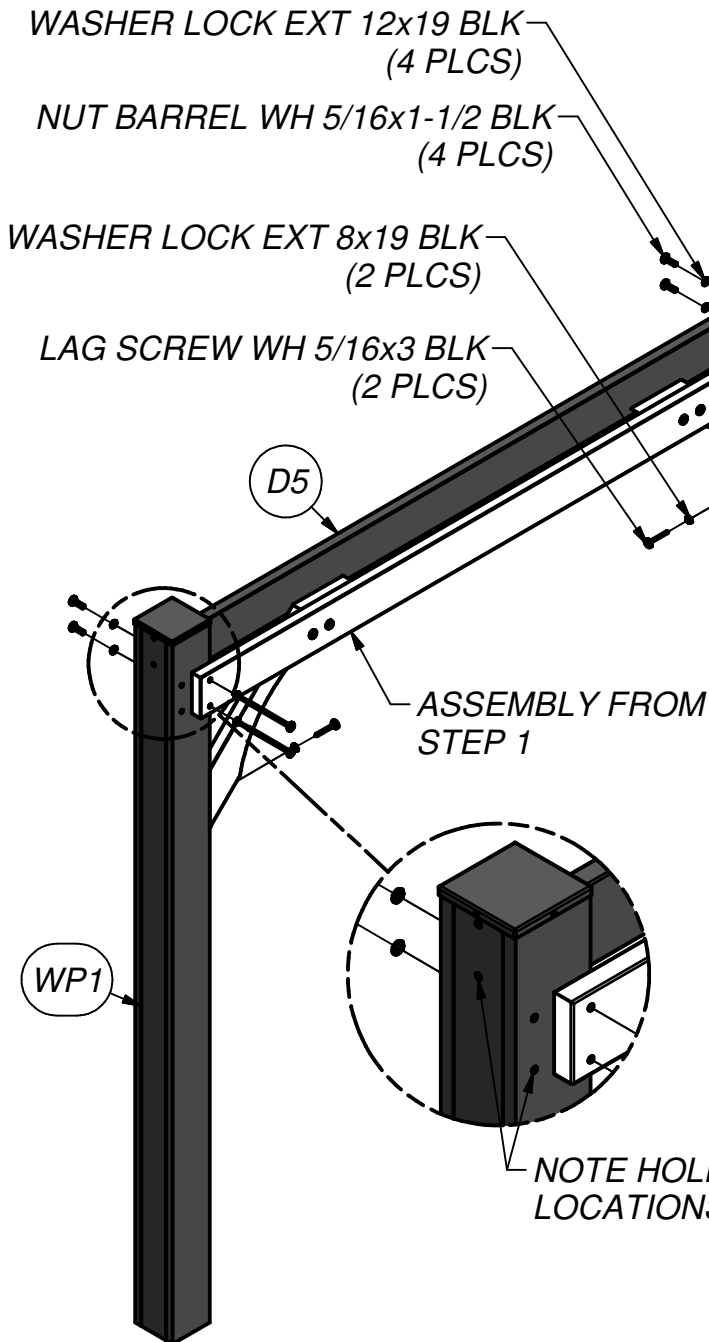

BOLT WH 5/16x7-1/4 BLK
(4 PLCS)

WASHER LOCK EXT 8x19 BLK
(4 PLCS)





(8) **D6 - JOIST END - W4L11633**
1 3/8"x5 1/4"x15" (36x134x381)

STEP 5

BUILD BOTH SIDES

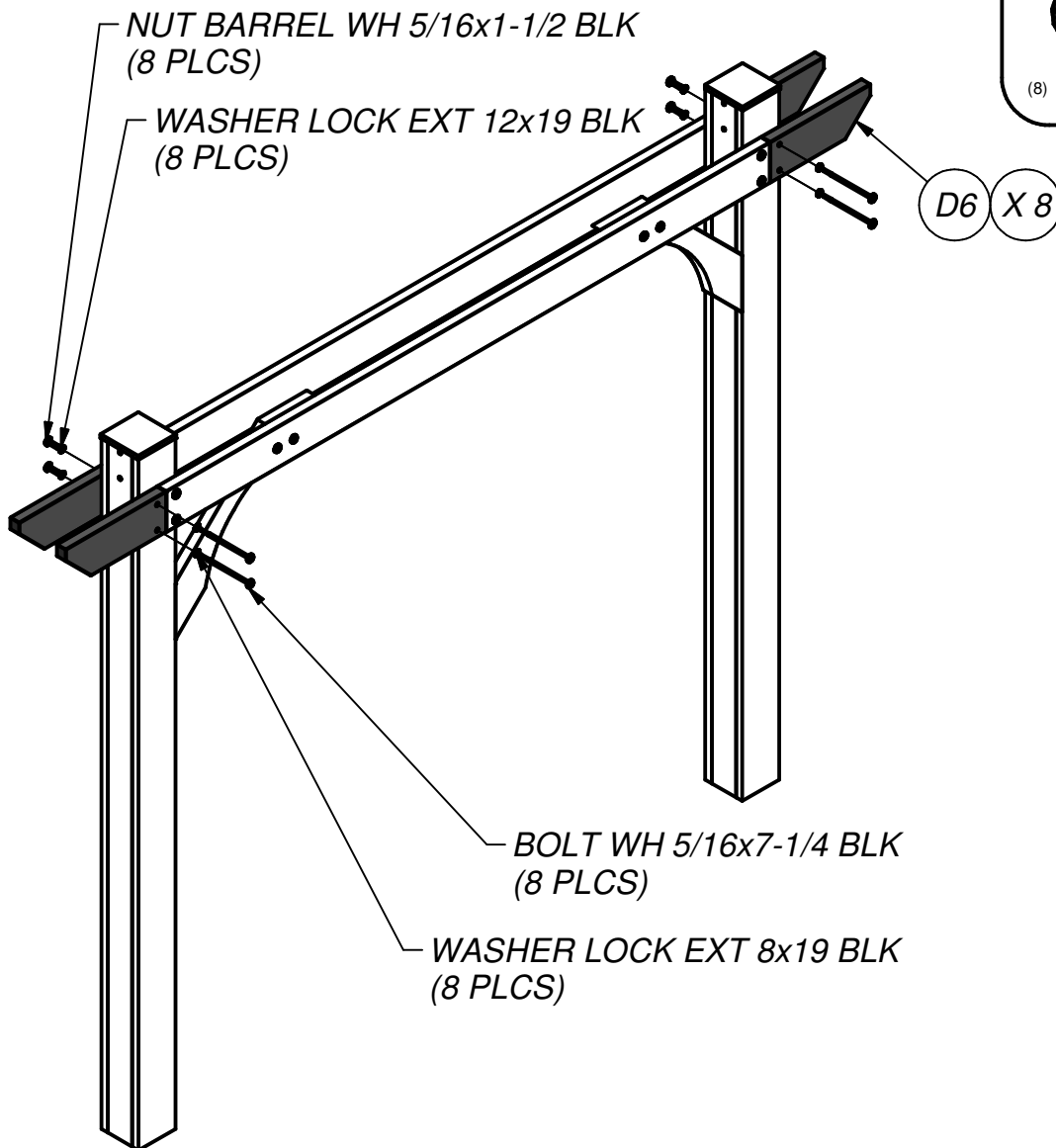
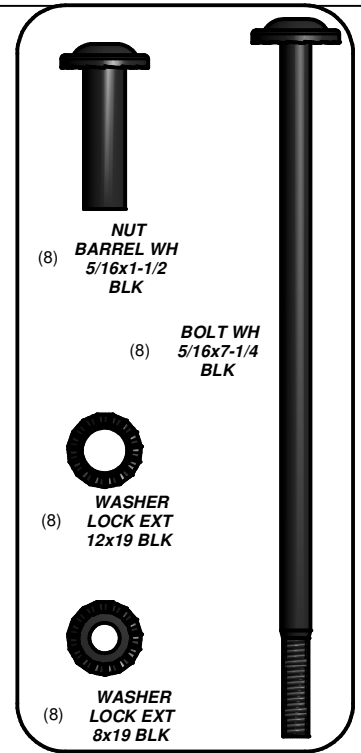

STEP 6

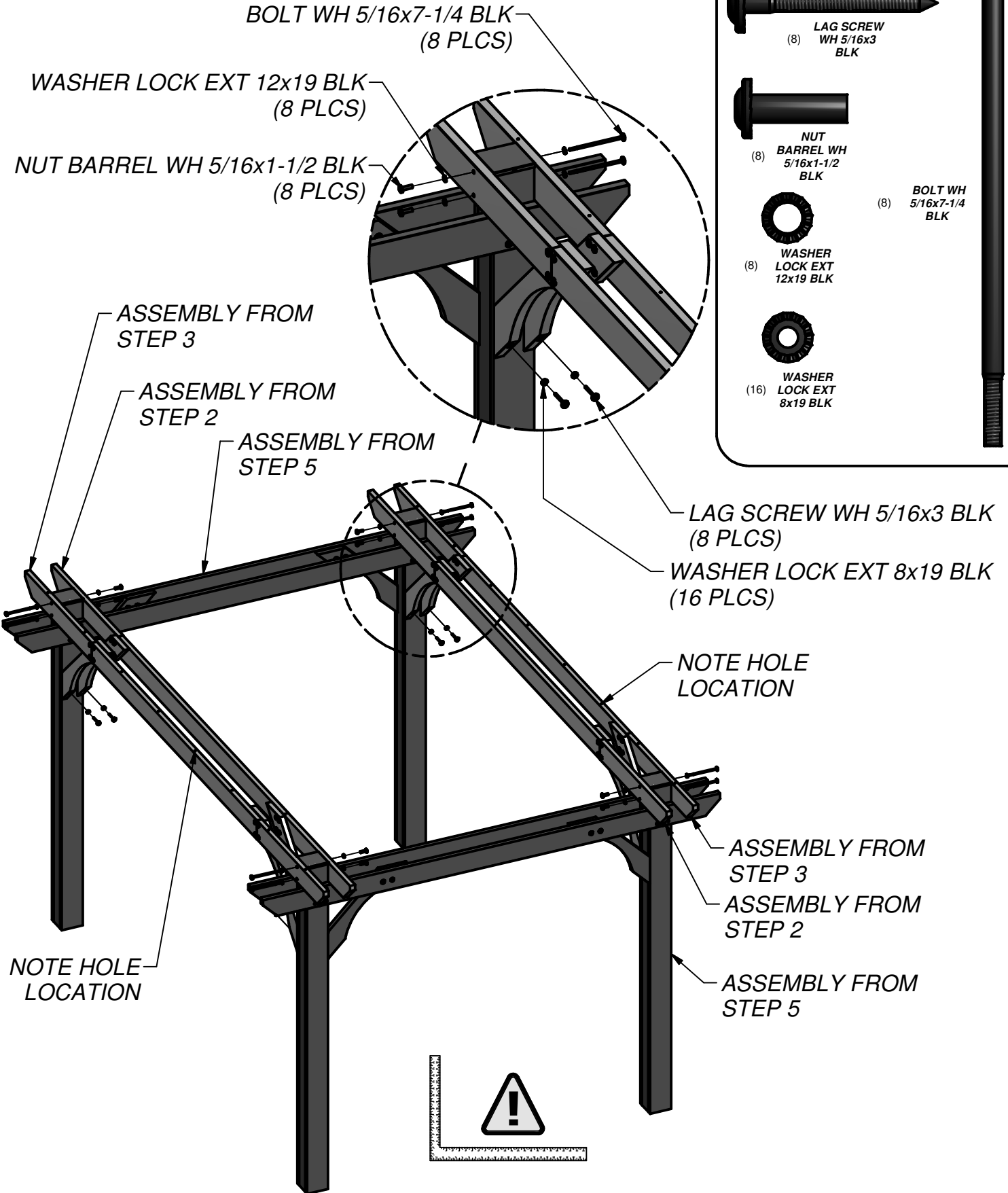



D3 - SLOTTED JOIST - W4L11637
(8) 1 3/8"x5 1/4"x114" (36x134x2896)

STEP 7

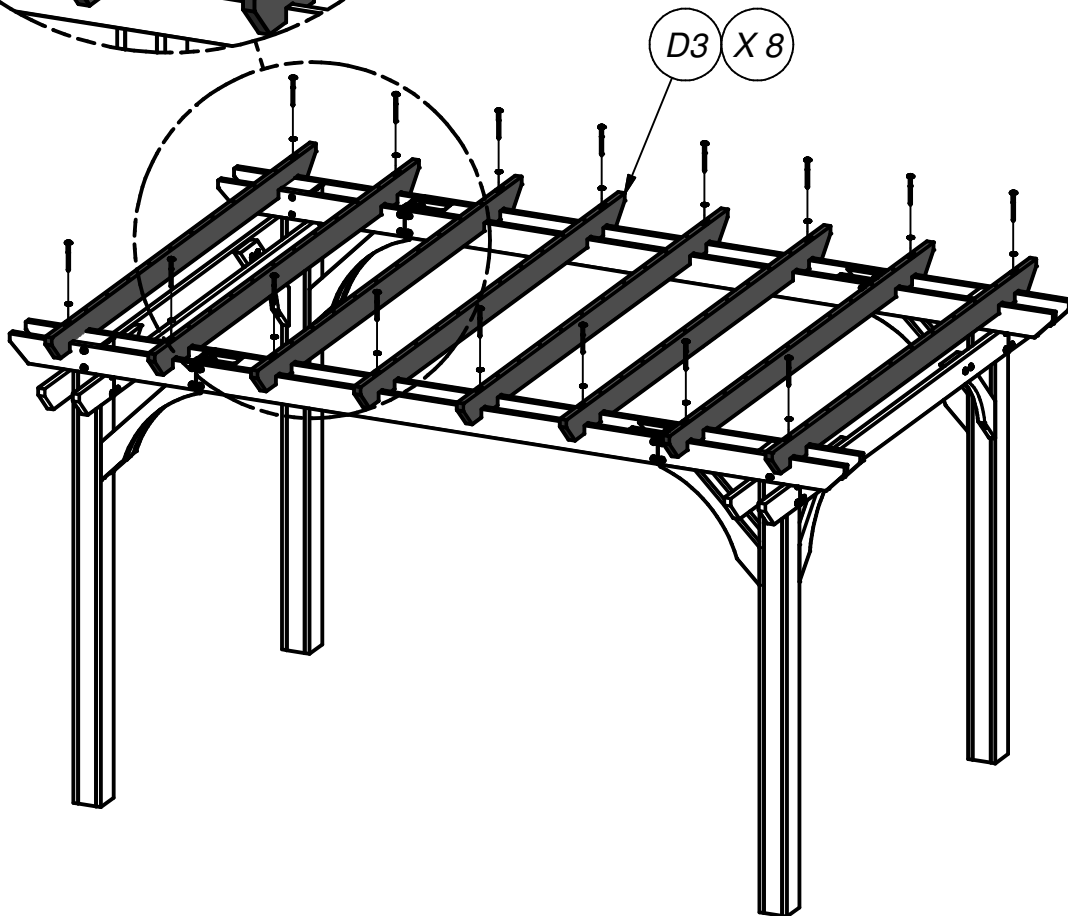
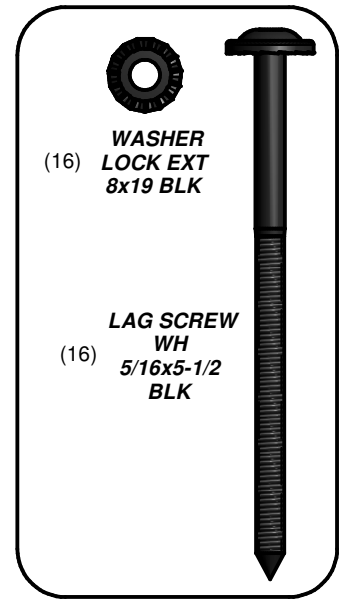
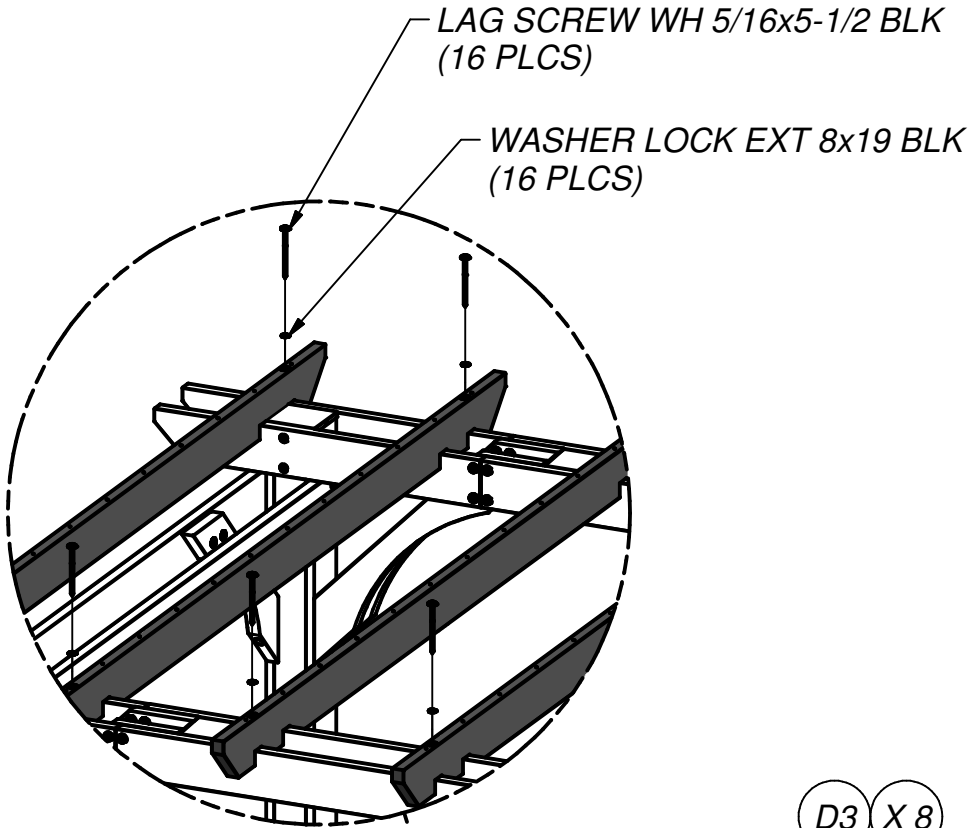



P1 - PURLIN - W4L11639
(12) 1 3/8"x1 3/8"x69 5/8" (36x36x1767)



P2 - PURLIN - W4L11640
(12) 1 3/8"x1 3/8"x90 1/4" (36x36x2291)

STEP 8

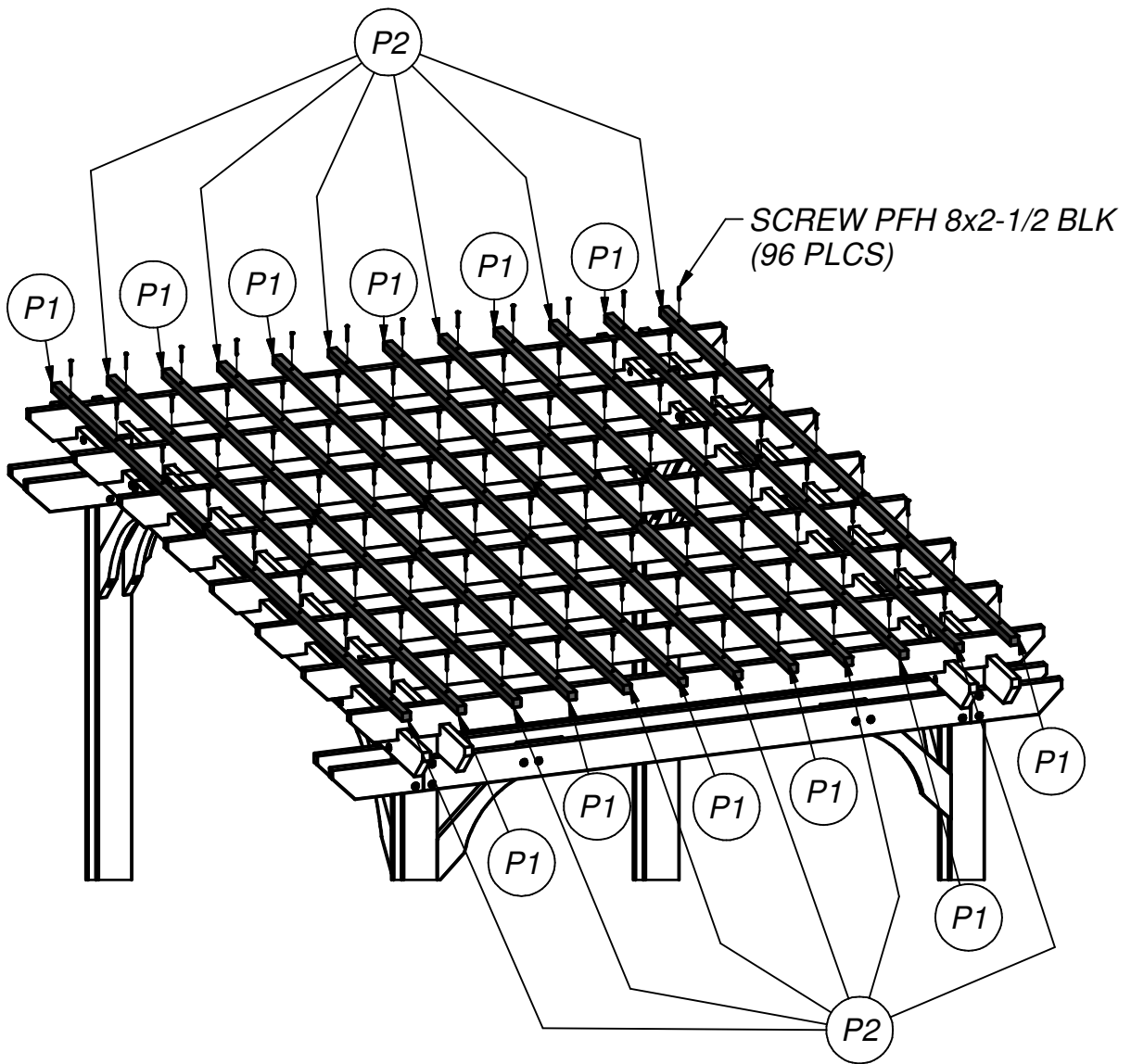
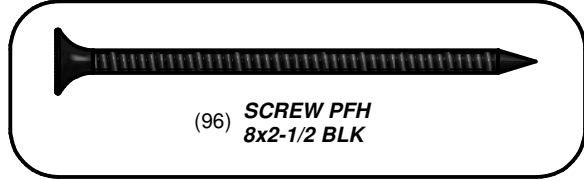

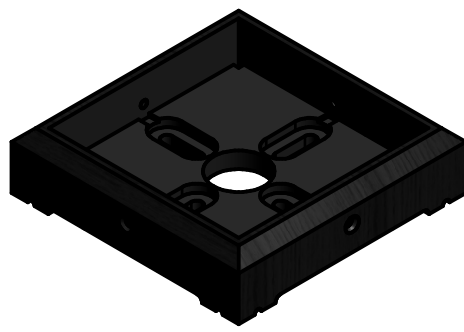

(4) HT - FOOT 142 SQUARE POST - A100029

STEP 9

IF PLACING PERGOLA ON CONCRETE, PLACE THE PERGOLA EXACTLY WHERE IT WILL BE ANCHORED WHEN COMPLETED AND SLIDE A FOOT UNDER EACH POST.

*NOTE:
IF NOT PLACING ON CONCRETE, PROCEED TO STEP 13.*

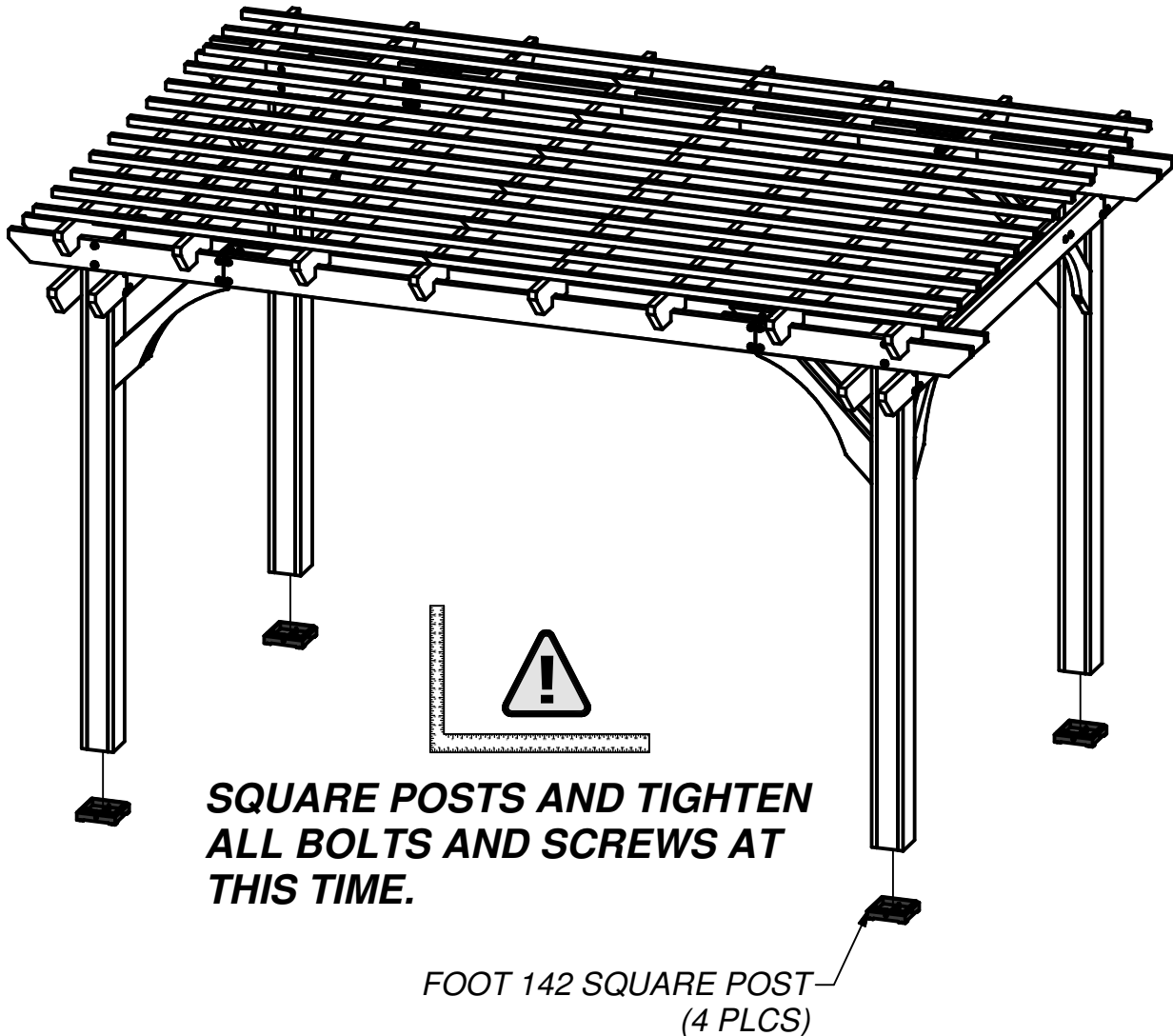

STEP 10

USE CHALK TO TRACE AROUND THE EDGES OF EACH FOOT.

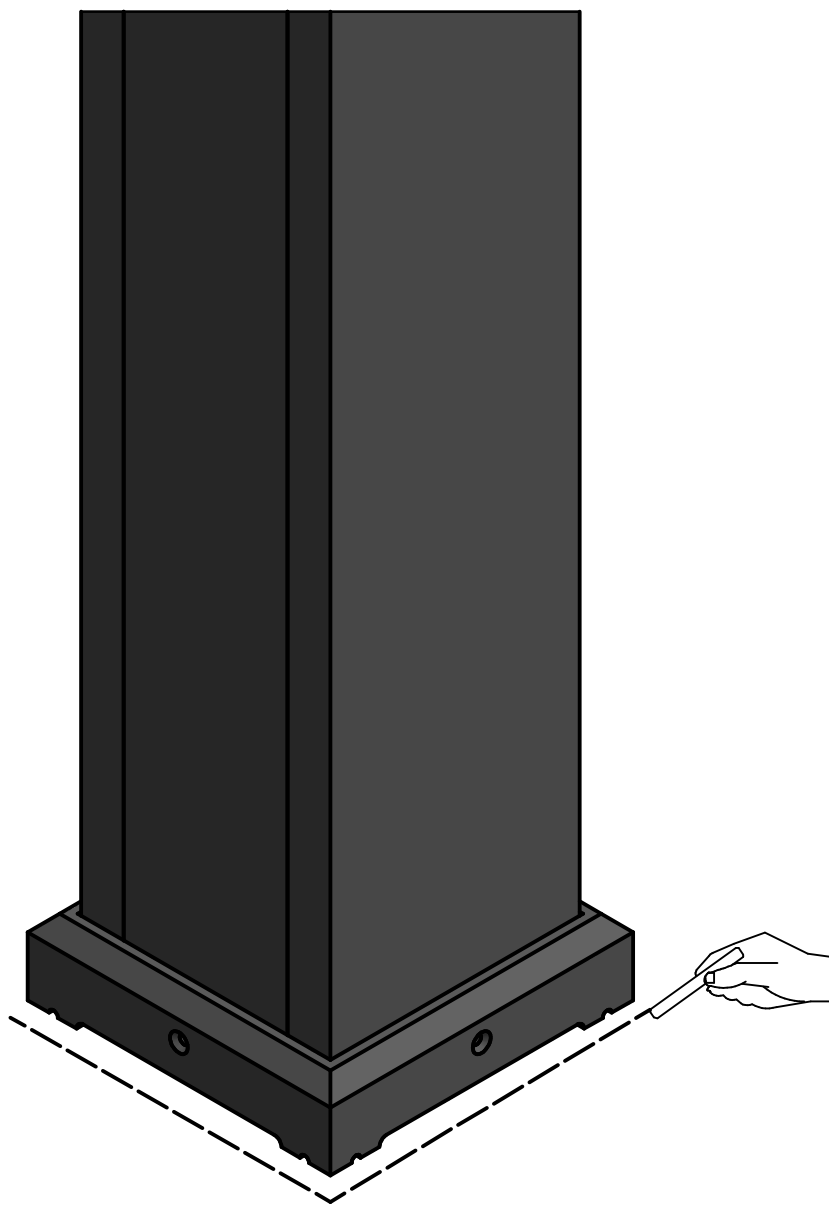

STEP 11

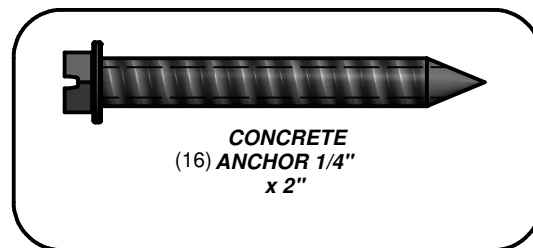

MOVE THE PERGOLA ASIDE, PLACE EACH FOOT INSIDE THE CHALK LINES. USE A 3/16" CONCRETE DRILL BIT TO PILOT HOLES INTO THE CONCRETE.

NEXT, USE (4) 1/4 x 2" CONCRETE ANCHORS TO ATTACH EACH FOOT.

CONCRETE ANCHOR 1/4" x 2"
(16 PLCS)

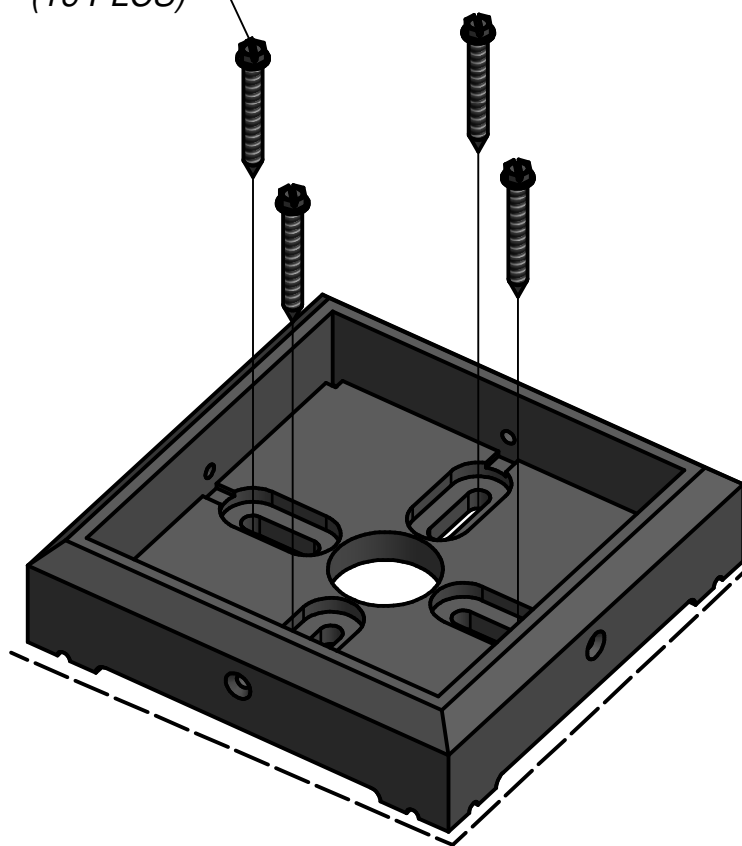

STEP 12

MOVE THE PERGOLA BACK IN PLACE, SETTING EACH POST INSIDE A FOOT.

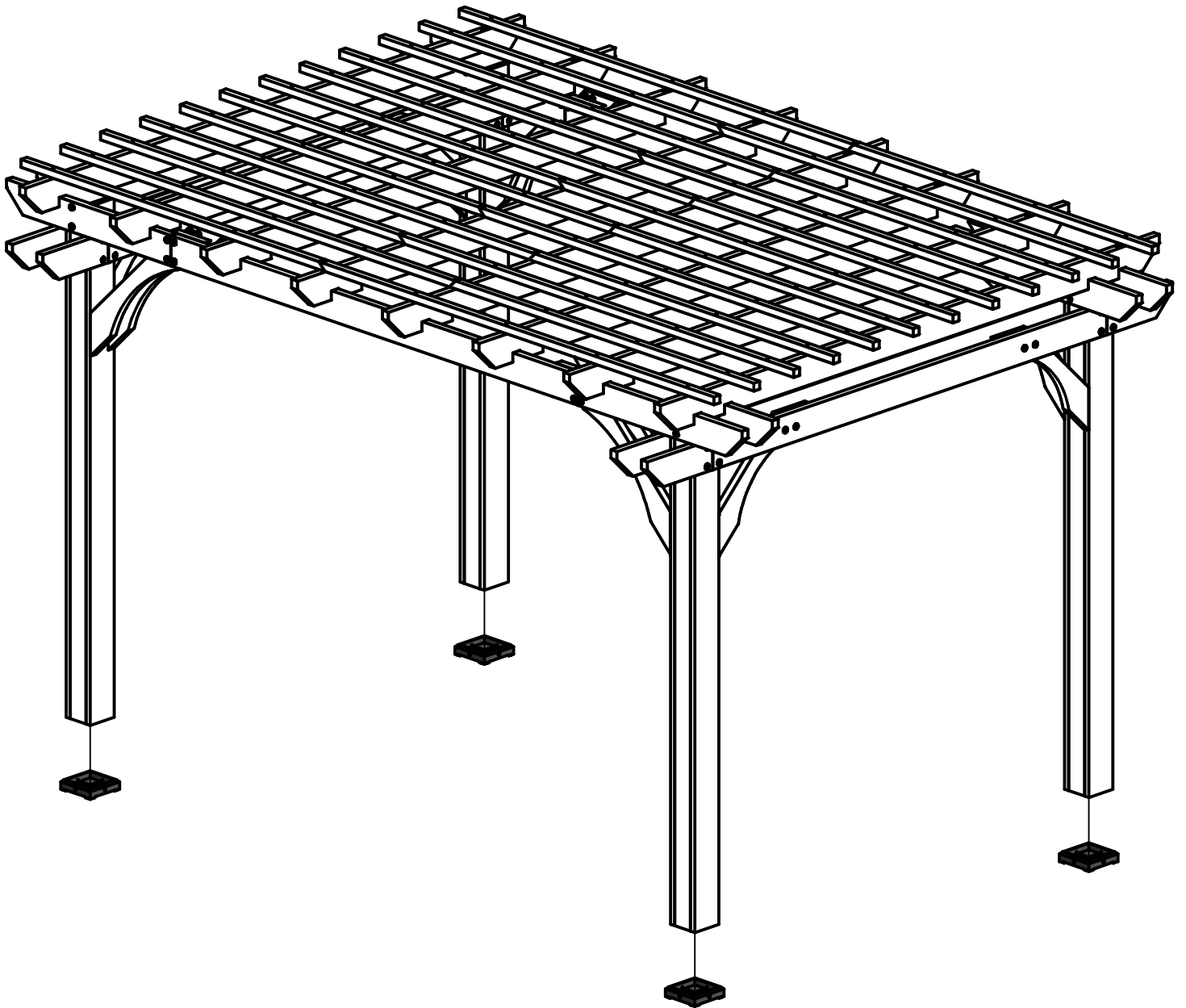

STEP 13

ATTACH FEET TO EACH POST

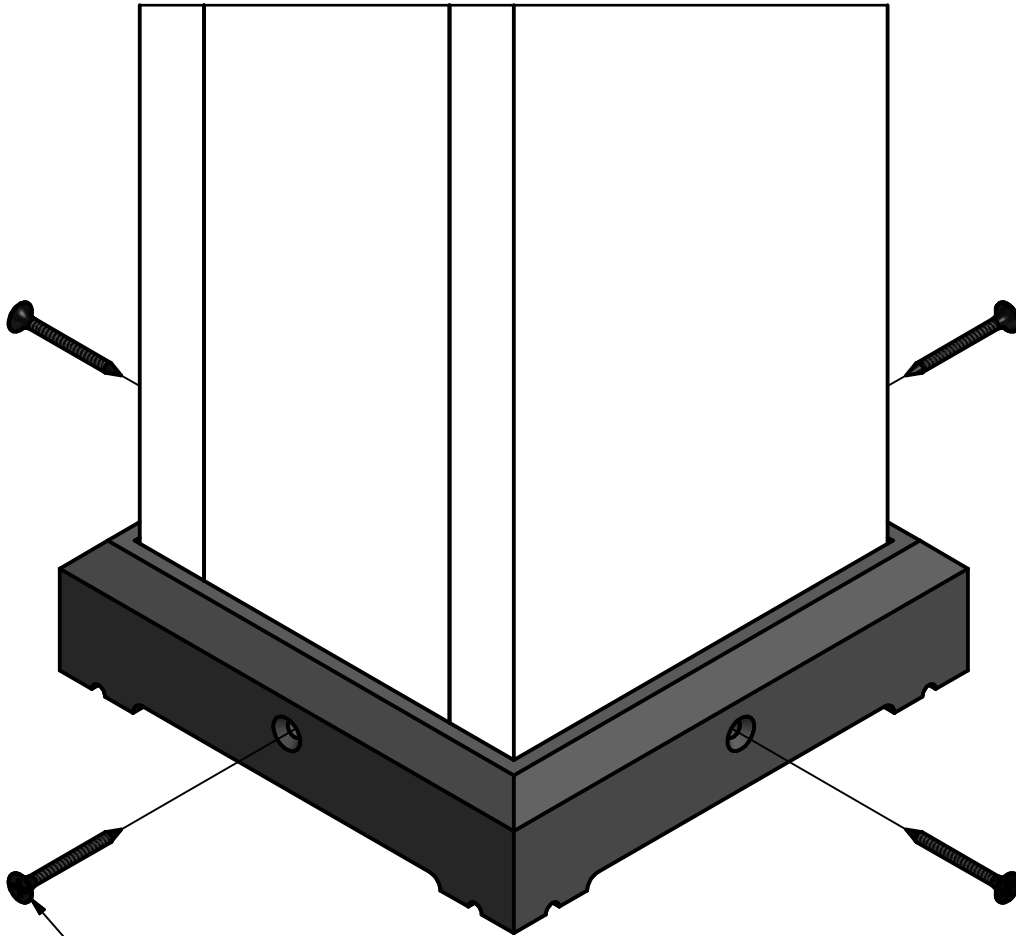
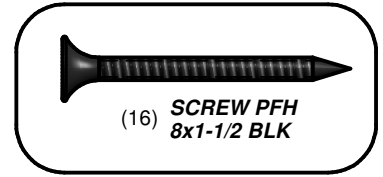

*SCREW PFH 8x1-1/2 BLK
(16 PLCS)*

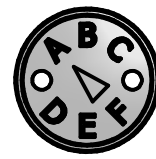

(1) XR - BYD ID TAG (SMALL) WITHOUT AGES - A100241

(1) SQ - "A" REVISION TAG - A100314

STEP 14

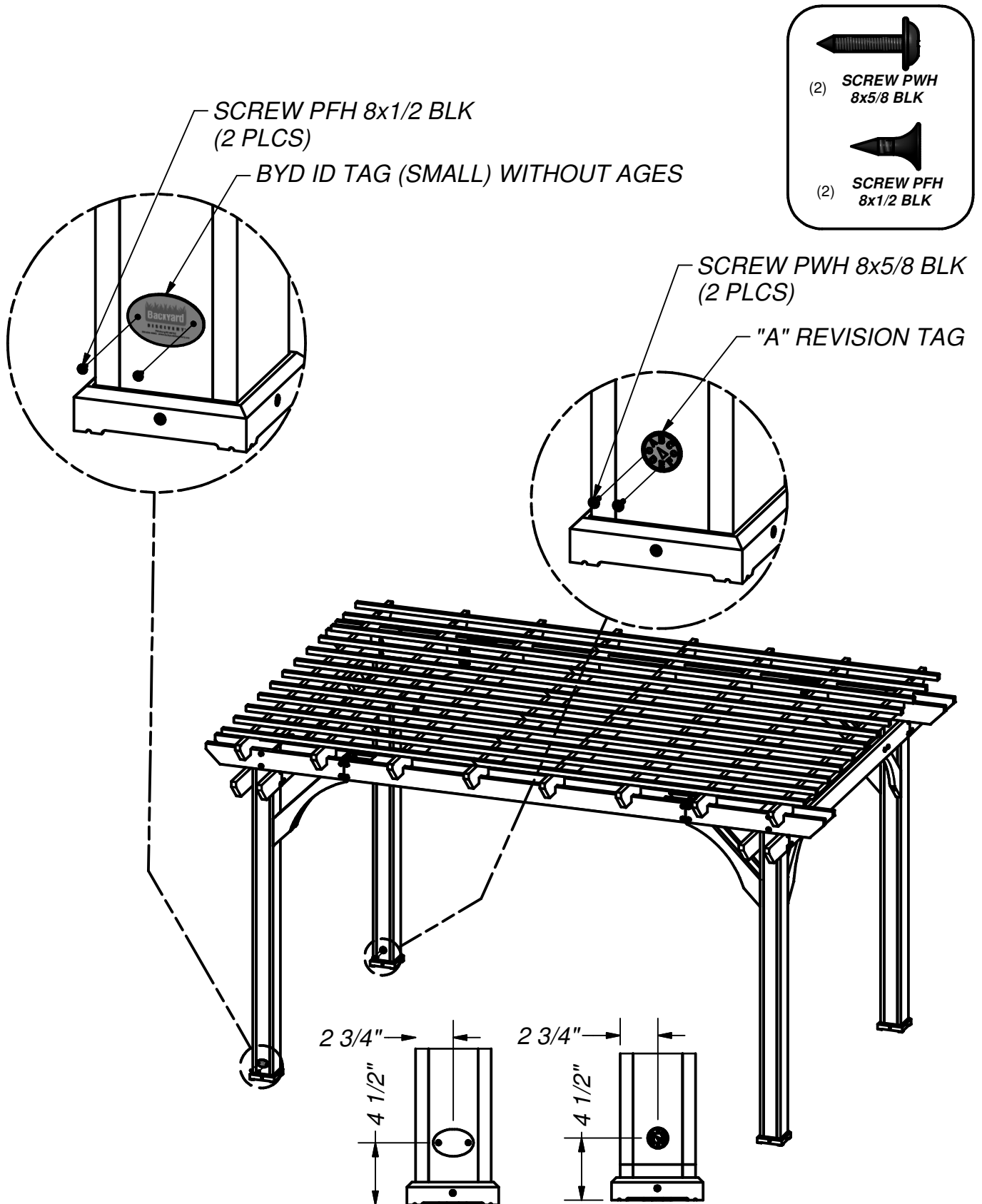

Limited Warranty

This Limited Warranty by Backyard Discovery applies to products manufactured under the Backyard Discovery brand or its other brands including but not limited to Backyard Botanical, Adventure Playsets, and Leisure Time Products.

Backyard Discovery warrants that this product is free from defect in materials and workmanship for a period of one (1) year from the original date of purchase. This one (1) year warranty covers all parts including wood, hardware, and accessories. All wood carries a five (5) year pro-rated warranty against rot and decay. Refer to the schedule below for charges associated with replacement of parts under this Limited Warranty. In addition, Backyard Discovery will replace any parts within the first 30 days from date of purchase found to be missing from or damaged in the original packaging.

This warranty applies to the original owner and registrant and is **non-transferable**. Regular maintenance is required to assure maximum life and performance of this product and failure by the owner to maintain the product according to the maintenance requirements may void this warranty. Maintenance guidelines are provided in the Owner's Manual.

This Limited Warranty does not cover:

- Labor for any inspection
- Labor for replacement of any defective item(s)
- Incidental or consequential damages
- Cosmetic defects which do not affect performance or integrity of a part or the entire product
- Vandalism, improper use, failure due to loading or use beyond the capacities stated in the applicable Assembly Manual.
- Acts of nature including but not limited to wind, storms, hail, floods, excessive water exposure
- Improper installation including but not limited to installation on uneven, unlevel, or soft ground
- Minor twisting, warping, checking, or any other natural occurring properties of wood that do not affect performance or integrity

Backyard Discovery products have been designed for safety and quality. Any modifications made to the original product could damage the structural integrity of the unit leading to failure and possible injury. Modification voids any and all warranties and Backyard Discovery assumes no liability for any modified products or consequences resulting from failure of a modified product.

This product is warranted for RESIDENTIAL USE ONLY. Under no circumstance should a Backyard Discovery product be used in public settings. Such use may lead to product failure and potential injury. Any and all public use will void this warranty. Backyard Discovery disclaims all other representations and warranties of any kind, express or implied.

This Warranty gives you specific legal rights. You may have other rights as well which vary from state to state or province to province. This warranty excludes all consequential damages, however, some states do not allow the limitation or exclusion of consequential damages and therefore this limitation may not apply to you.

Pro Rated Part Replacement Schedule

<u>Product Age</u>	<u>Customer Pays</u>
All Parts	
0-30 days from date of purchase	\$0 and free shipping
31 days to 1 year	\$0 + S&H
Wood Rot and Decay Only	
1 year	\$0 and free shipping
2 years	20% + S&H
3 years	40% + S&H
4 years	60% + S&H
5 years	80% + S&H
Over 5 years	100% + S&H

