

61983

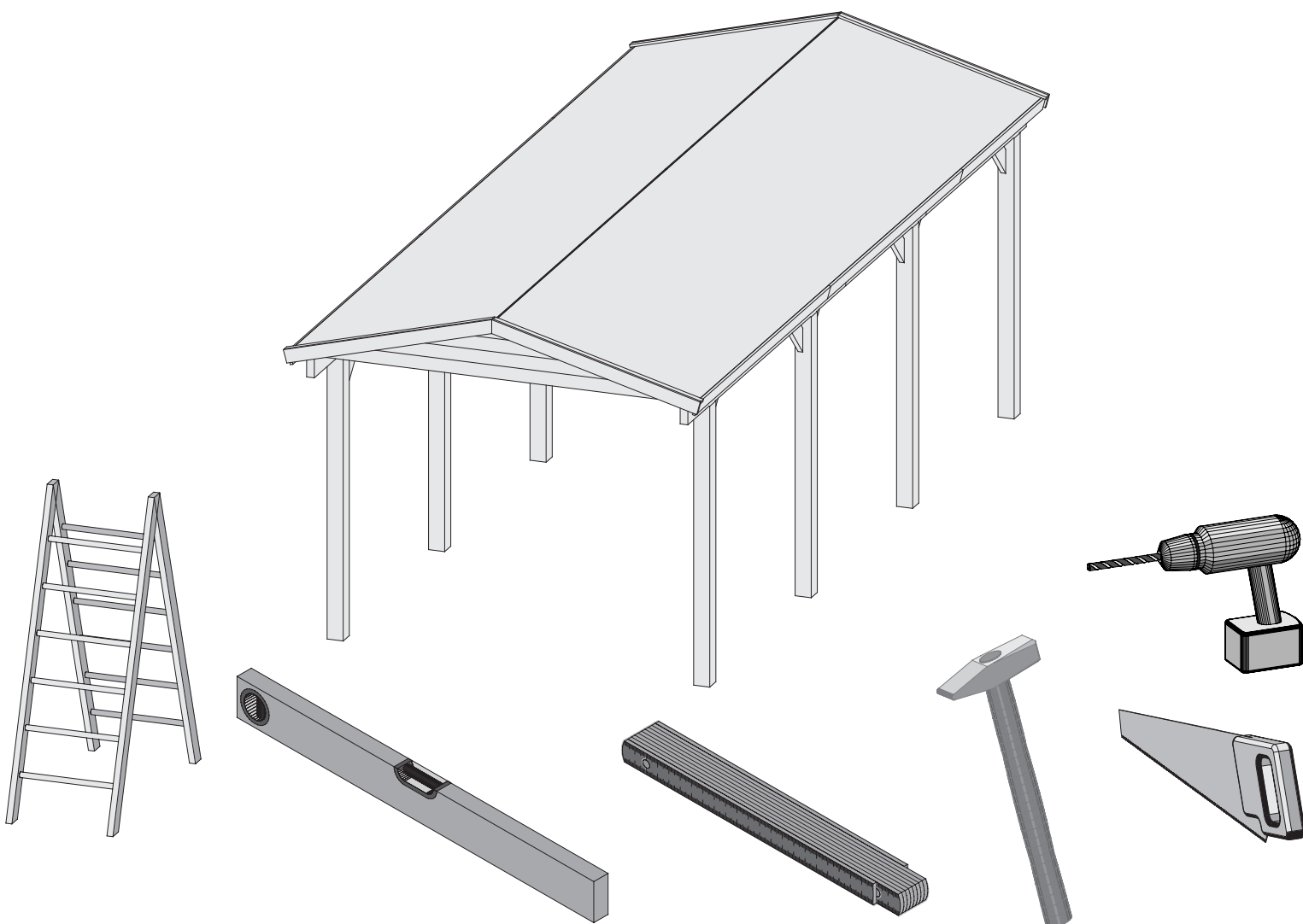

 **Aufbauanleitung**

 **notice de montage**

 **Building Instructions**

 **montagehandleiding**

 **Instrucciones de construcción**

 **Istruzioni per il montaggio**

 **Service-Hotline: +49 421 38693 33**



Vergleichen Sie zuerst die Materialliste mit Ihrem Paketinhalt! Bitte haben Sie Verständnis, dass Beanstandungen nur im nicht aufgebauten Zustand bearbeitet werden können!



Commencez par comparer la liste du matériel avec le contenu de votre paquet! Sachez que nous traitons uniquement les réclamations concernant le matériel à l'état non monté!



First compare the list of materials with your package contents! Please understand that complaints can be processed in the non-built status only!



Vergelijk eerst de lijst van materialen met de inhoud van uw pakket! Reclamaties kunnen alleen in behandeling worden genomen zolang de onderdelen nog niet zijn gemonteerd!



En primer lugar, compare la lista de material con el contenido del paquete. Rogamos entienda que las reclamaciones sólo pueden ser tramitadas antes de montar el objeto!



Confrontate questa distinta materiali prima con il contenuto del pacchetto! Vi preghiamo di comprendere che eventuali reclami possono essere accolti solo prima del montaggio!



61983

	2 x A6a	1740 x 95 x 18mm	ID 51818
--	---------	------------------	----------

	4 x H3	1447 x 95 x 18mm	ID 43480
	4 x H4	1496 x 95 x 18mm	ID 43478

600 x		ID 25453
-------	--	----------

	2 x B1	2100 x 120 x 120mm	ID 40629
--	--------	--------------------	----------

	34 x K2	1640 x 96 x 19mm	ID 42282
--	---------	------------------	----------

	4 x	13,5 x 44 mm	ID 12011
--	-----	--------------	----------

	2 x C3	1820 x 155 x 55mm	ID 60150
--	--------	-------------------	----------

4 x		ID 21292
-----	--	----------

	4 x G1	585 x 120 x 34mm	ID 40675
--	--------	------------------	----------

	1 x	7,5m ²	ID 3710
--	-----	-------------------	---------

2 x		12 x 140mm	ID 40787
-----	--	------------	----------

	2 x F1	318 x 95 x 18mm	ID 43479
	2 x F2	416 x 95 x 18mm	ID 43477

	50 x	4 x 30mm	ID 3686
	80 x	4 x 50mm	ID 3688
	5 x	6 x 60mm	ID 14014
	5 x	6 x 120mm	ID 9205

	4 x H1	2891 x 95 x 18mm	ID 43481
--	--------	------------------	----------

2 x		ID 9253
-----	--	---------



Hinweis

Die Pfosten dieses Produkts müssen fest mit dem Untergrund verbunden werden. Dazu empfehlen wir H-Pfostenanker. Diese sollten erst nach dem Aufbau dieses Produkts endgültig mit Beton versehen werden. Die H-Pfostenanker und das zugehörige Befestigungsmaterial sind nicht im Lieferumfang dieses Produkts enthalten.

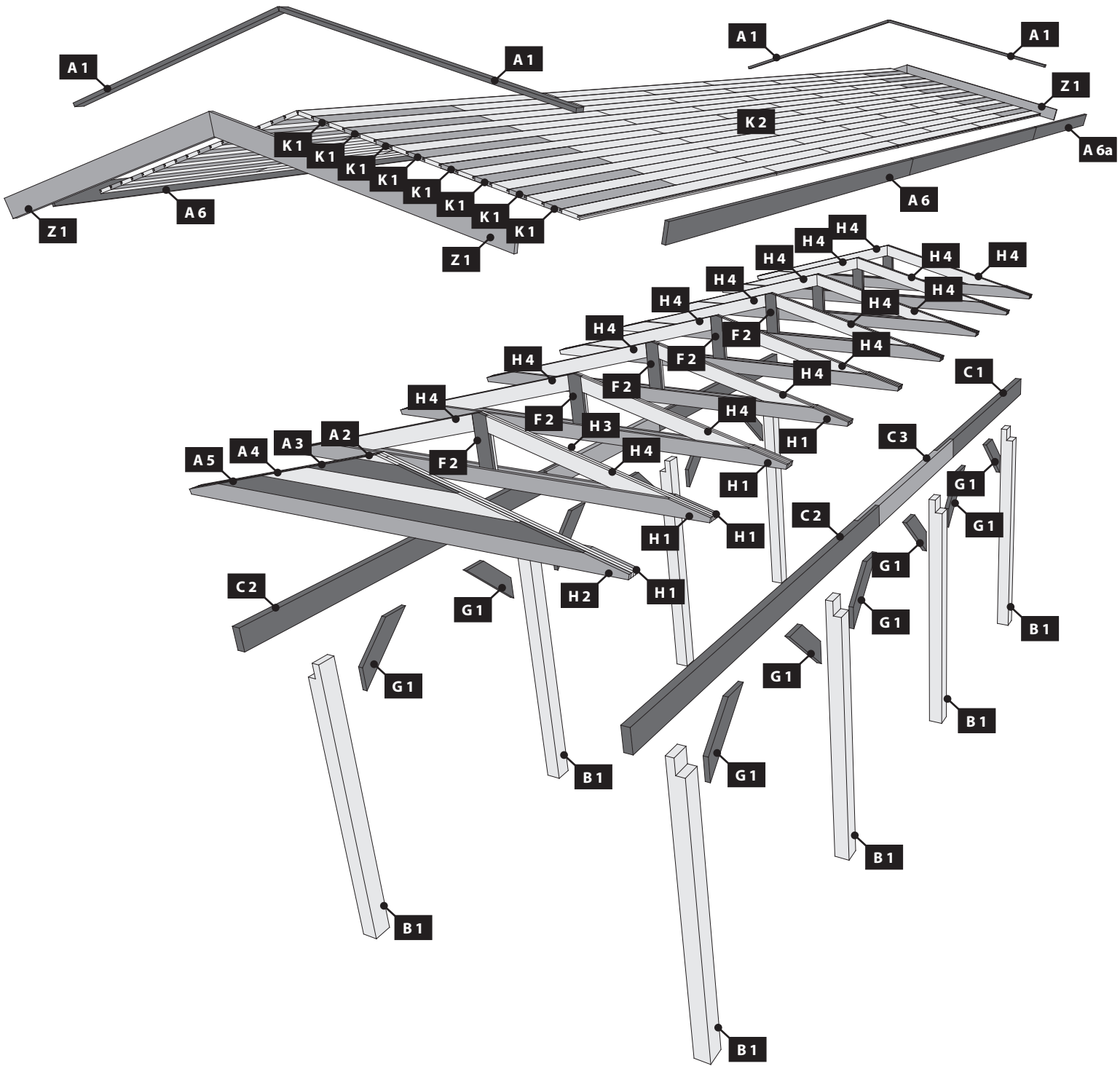

01 8x

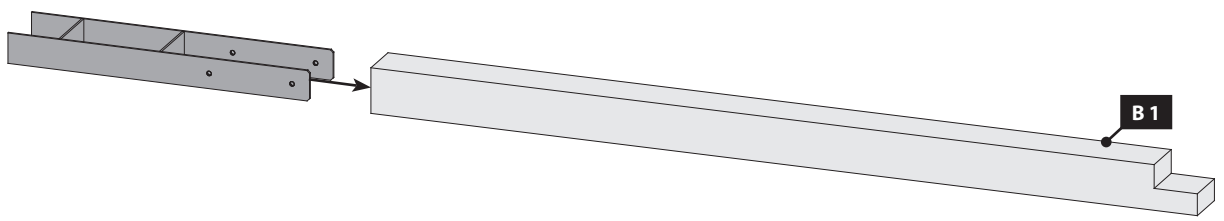

02 8x

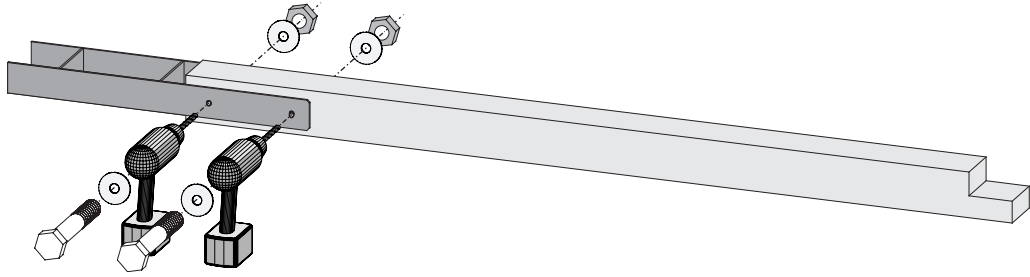

03

!!! A=B=C !!!

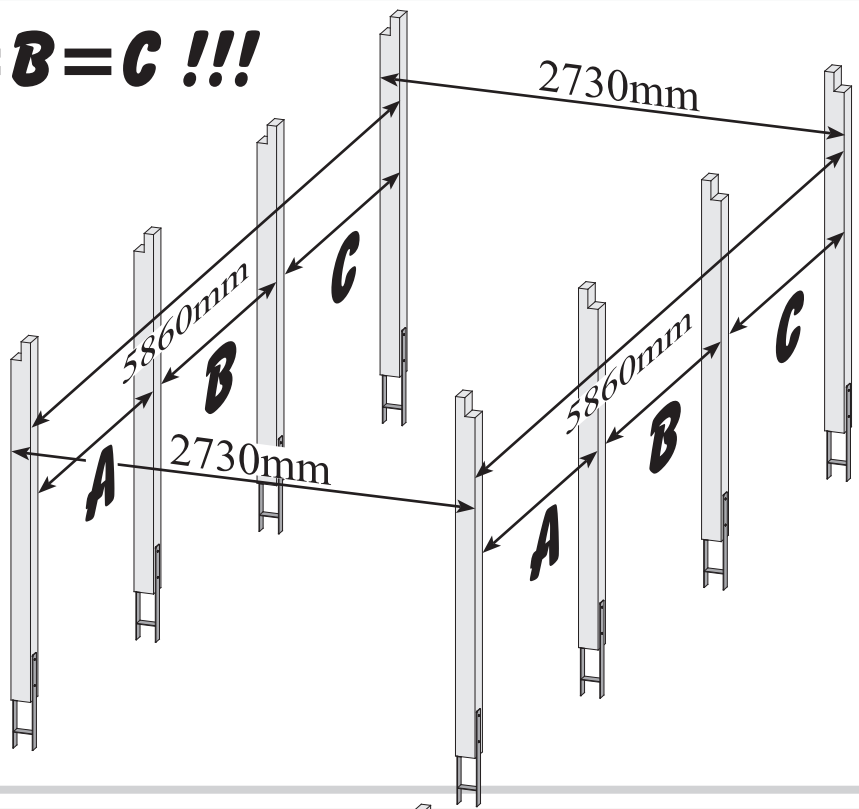

04

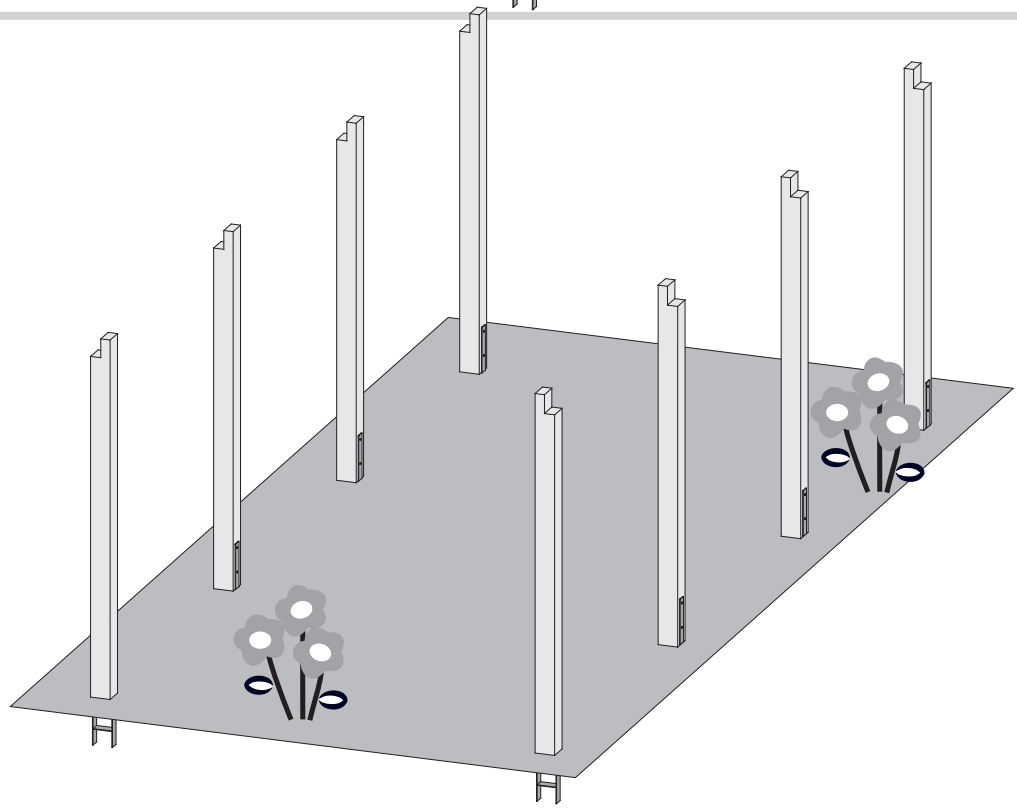

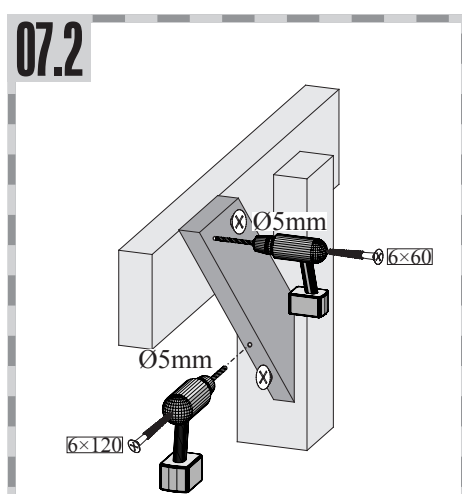
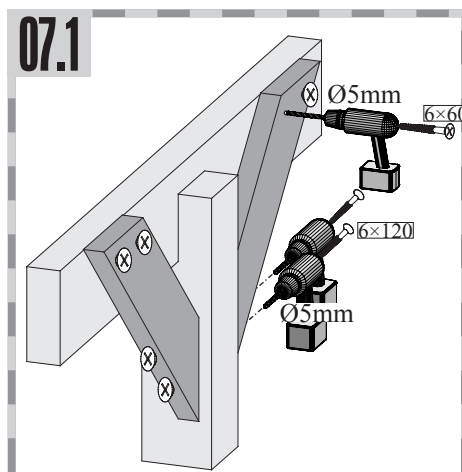
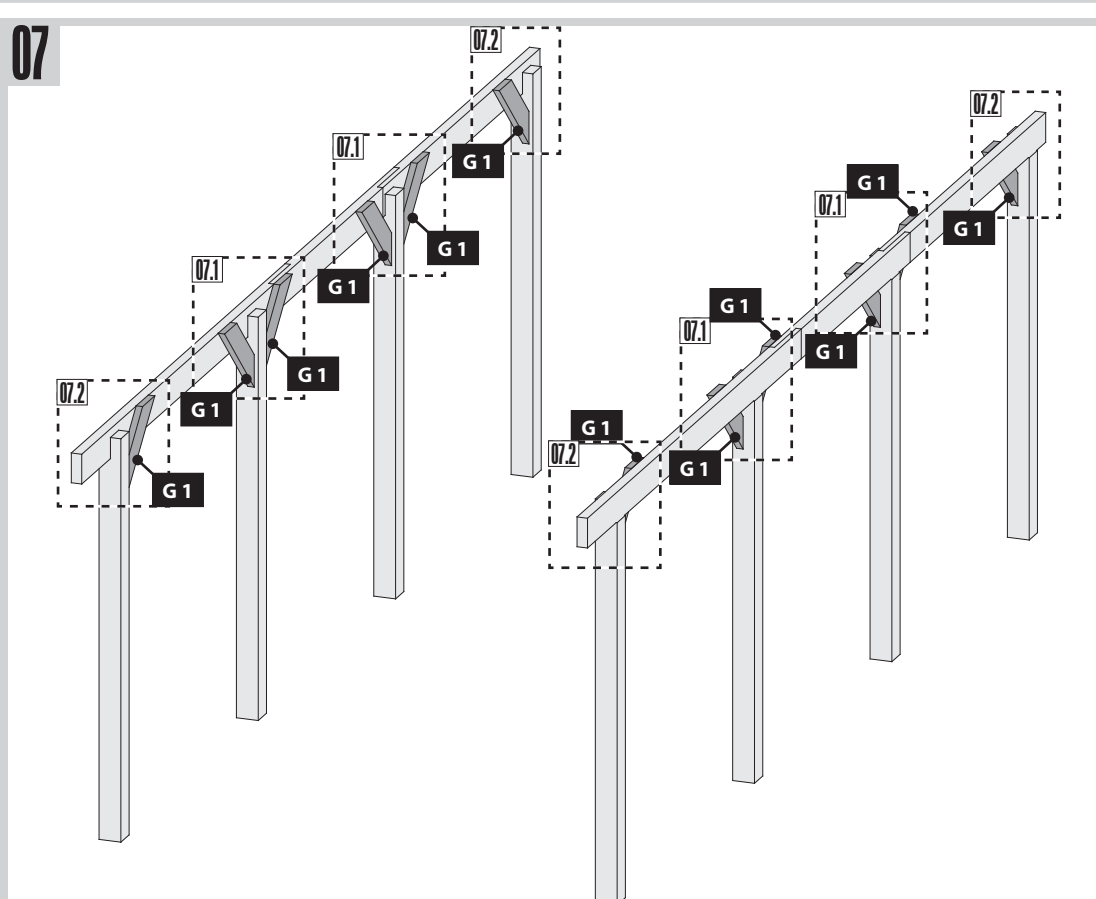
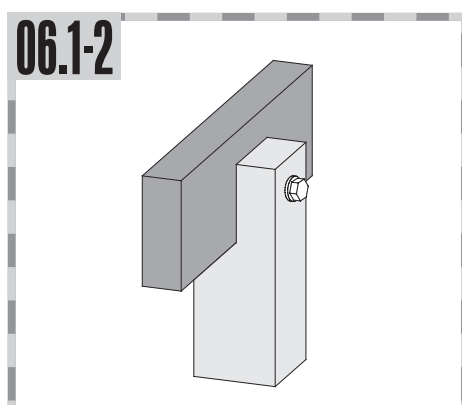
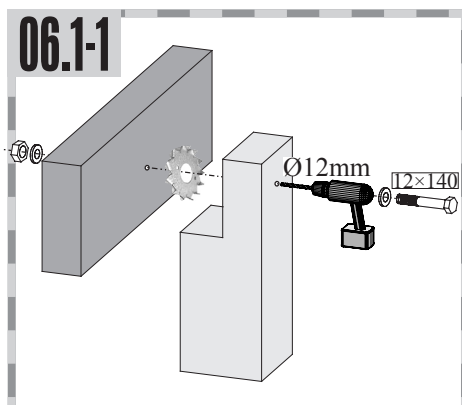
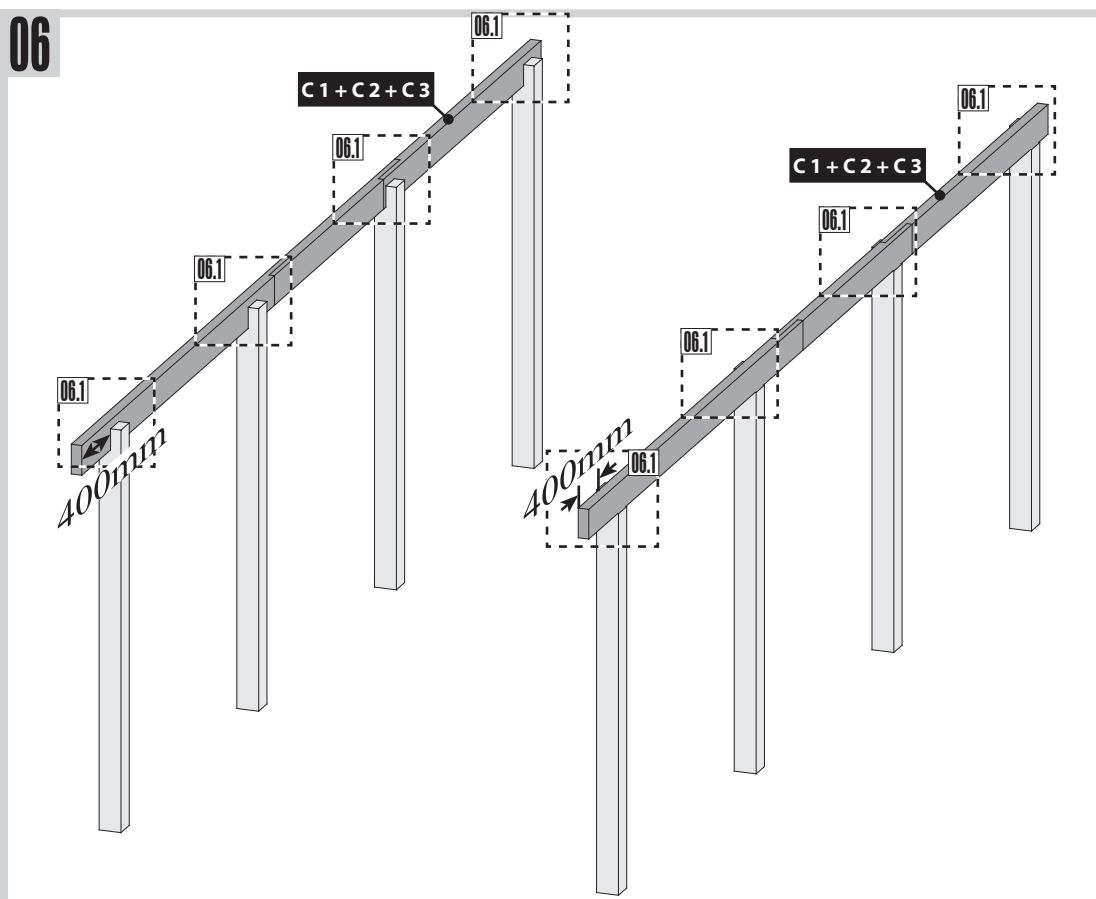
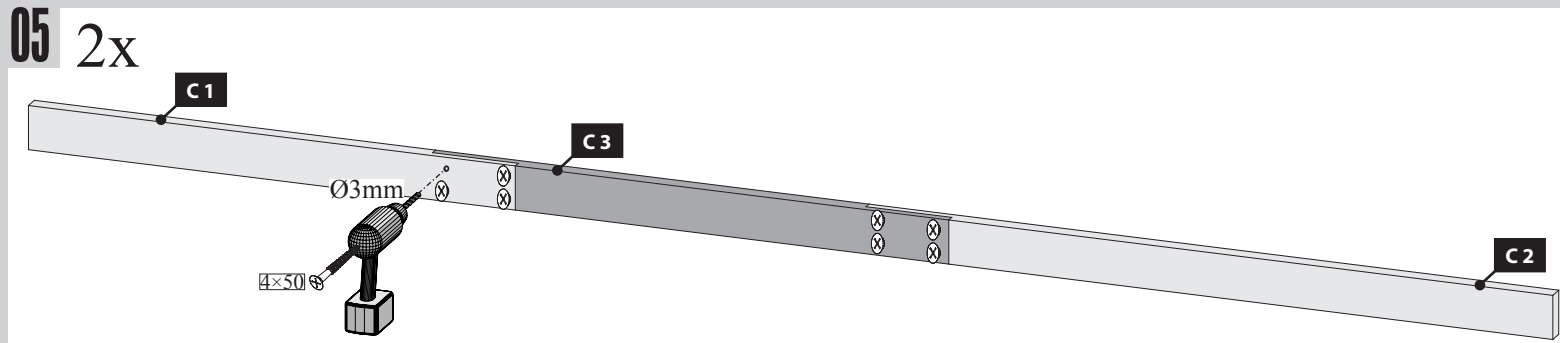

08 9x

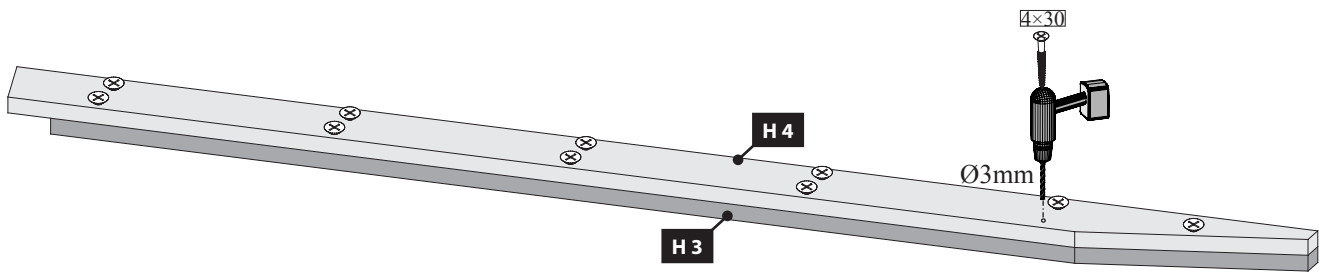

09 9x

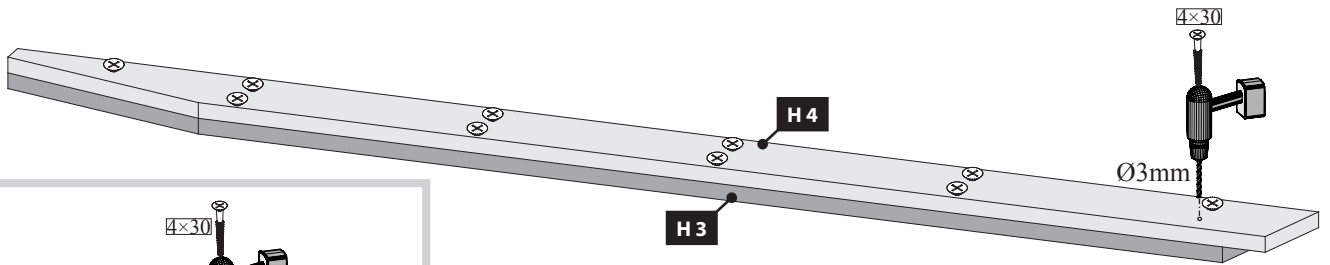

10 9x

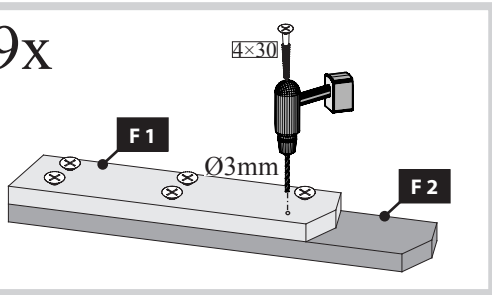

11 9x

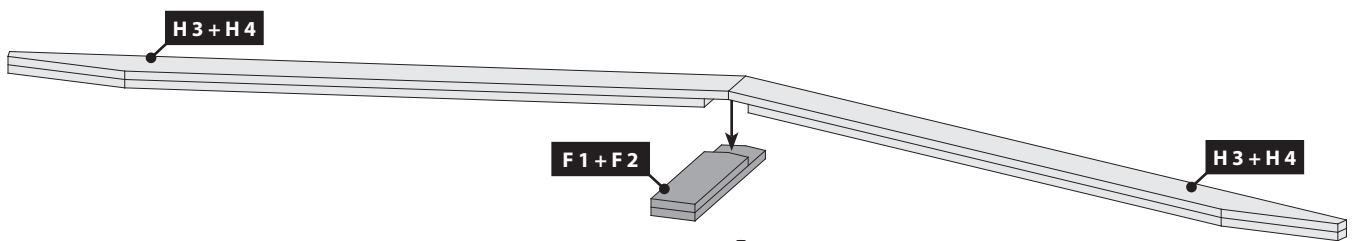

12 9x

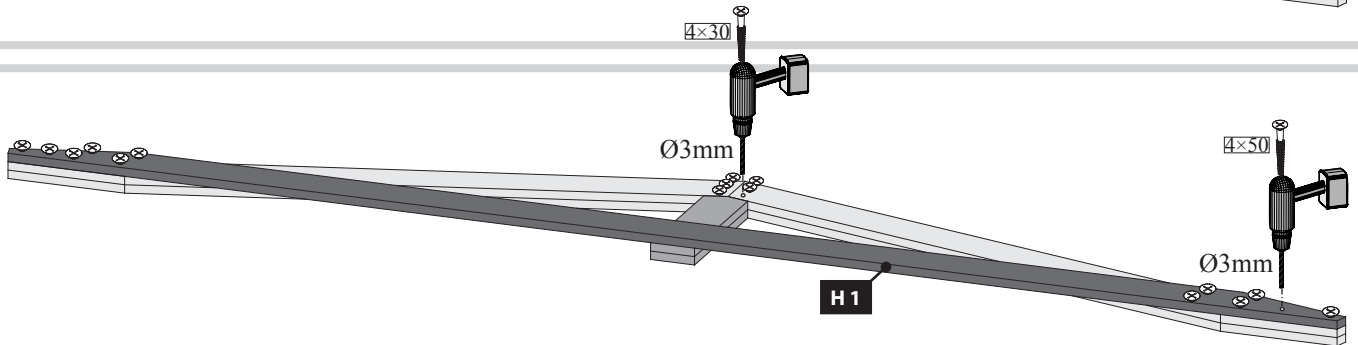

13 8x !!!

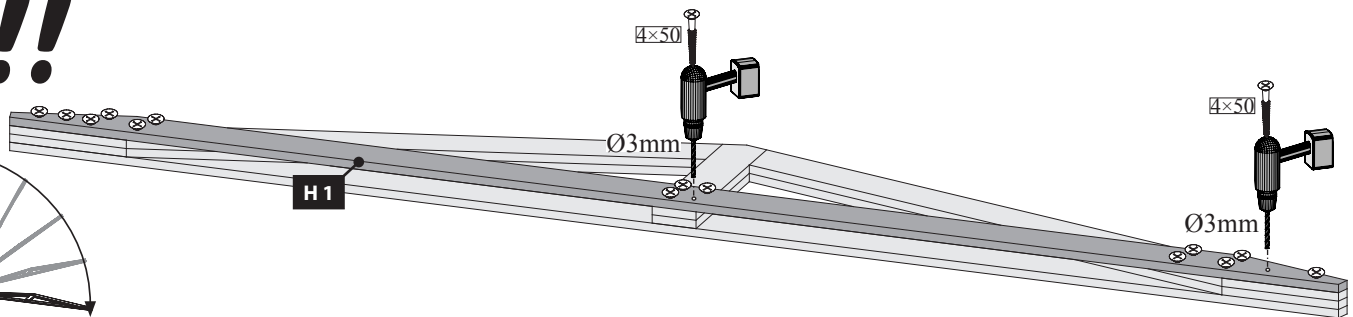
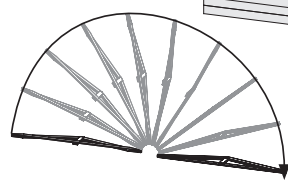

14 1x !!!

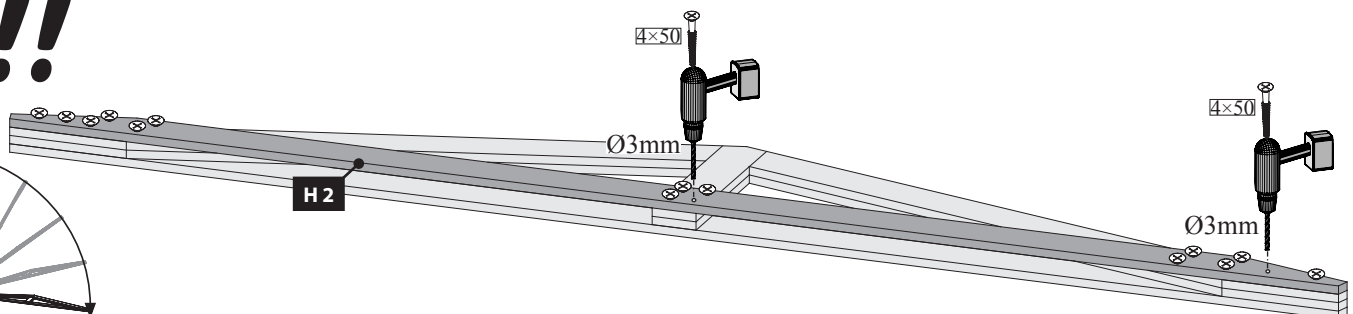
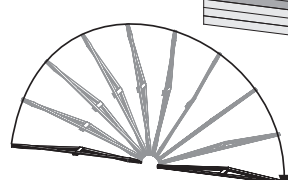

15 1x

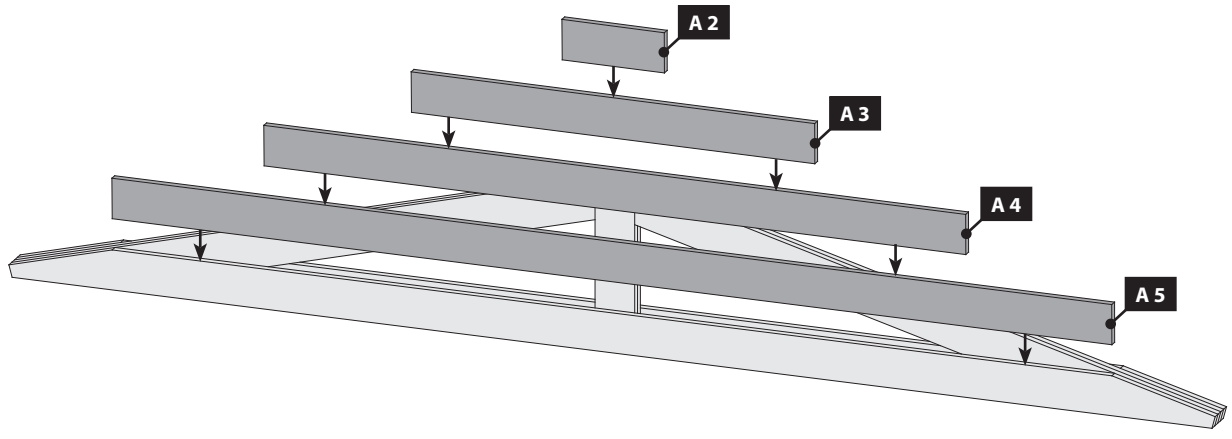

16 1x

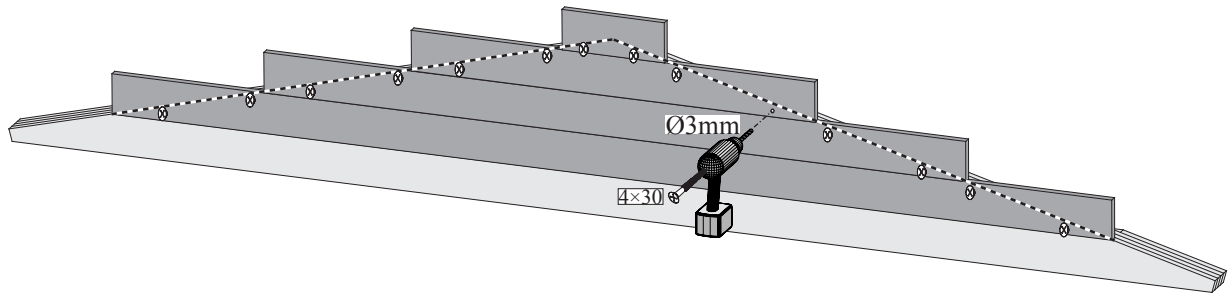

17 1x

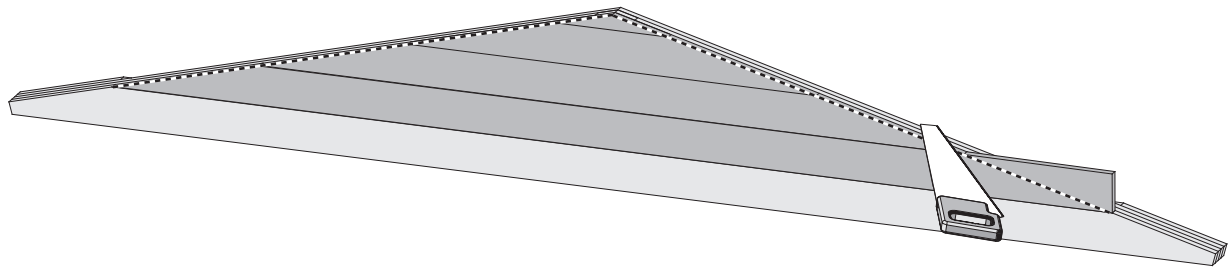

18

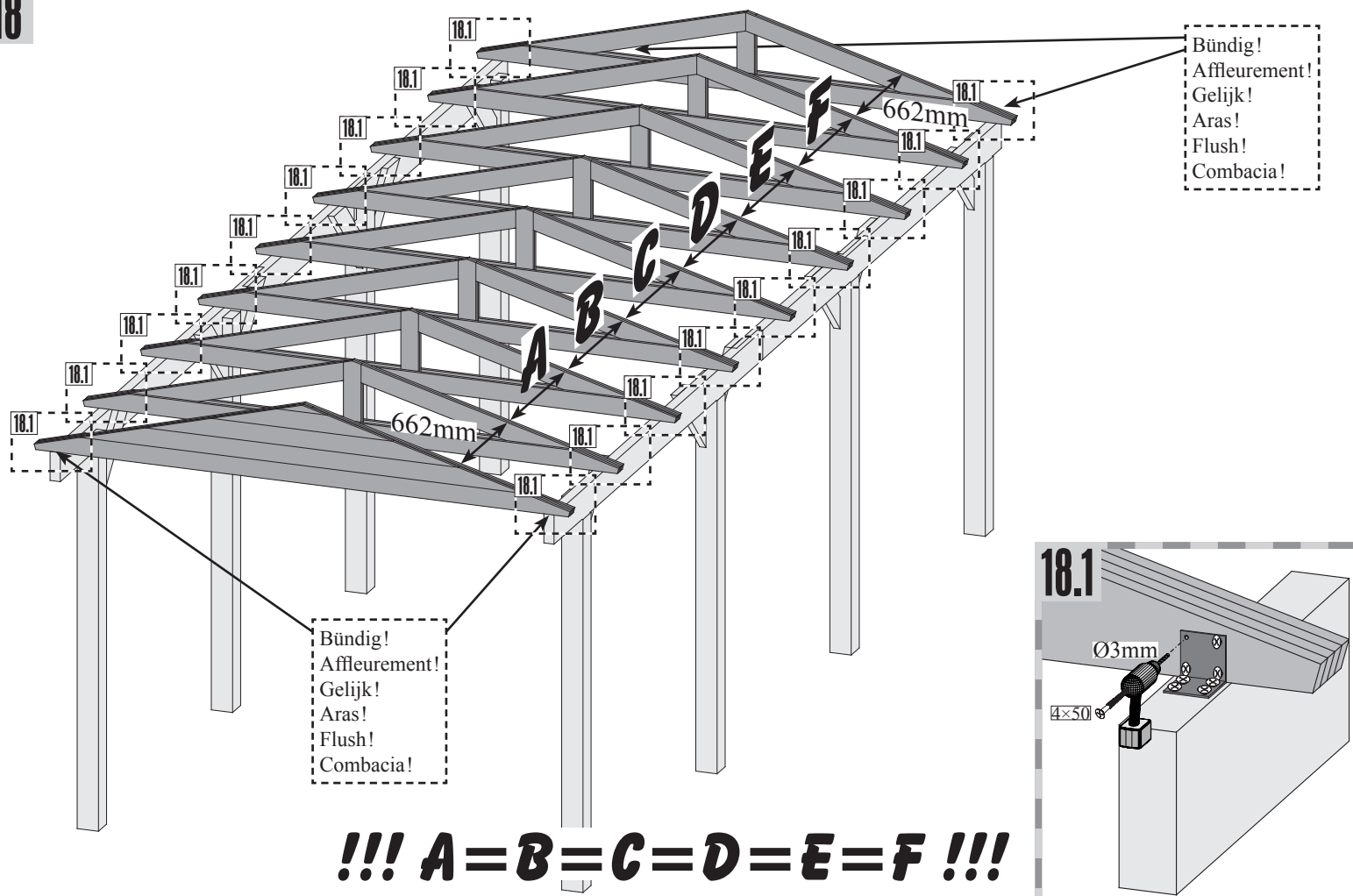

!!! A=B=C=D=E=F !!!

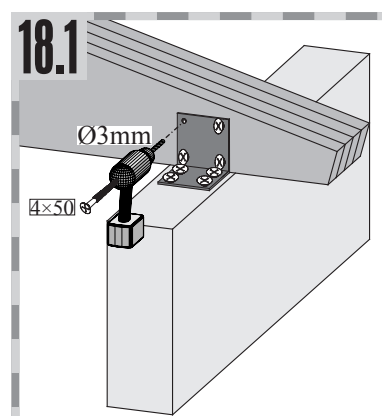

19

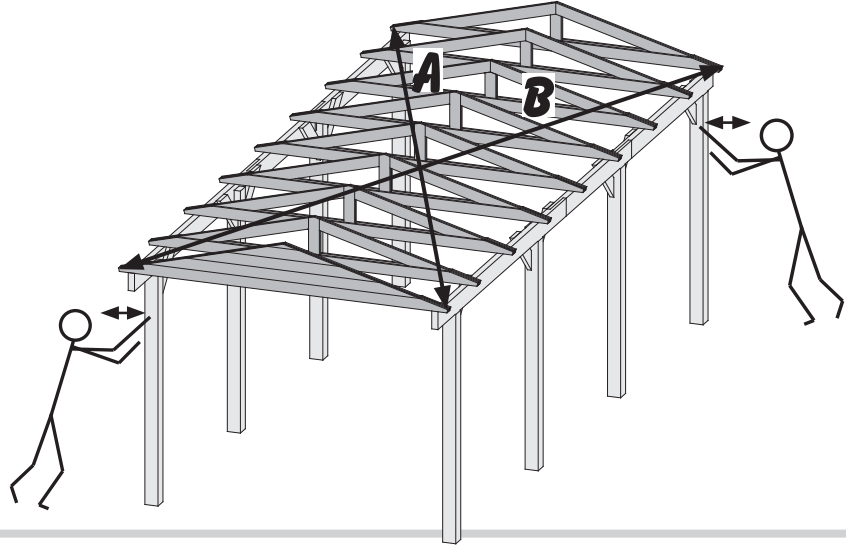

!!! A=B !!!

20

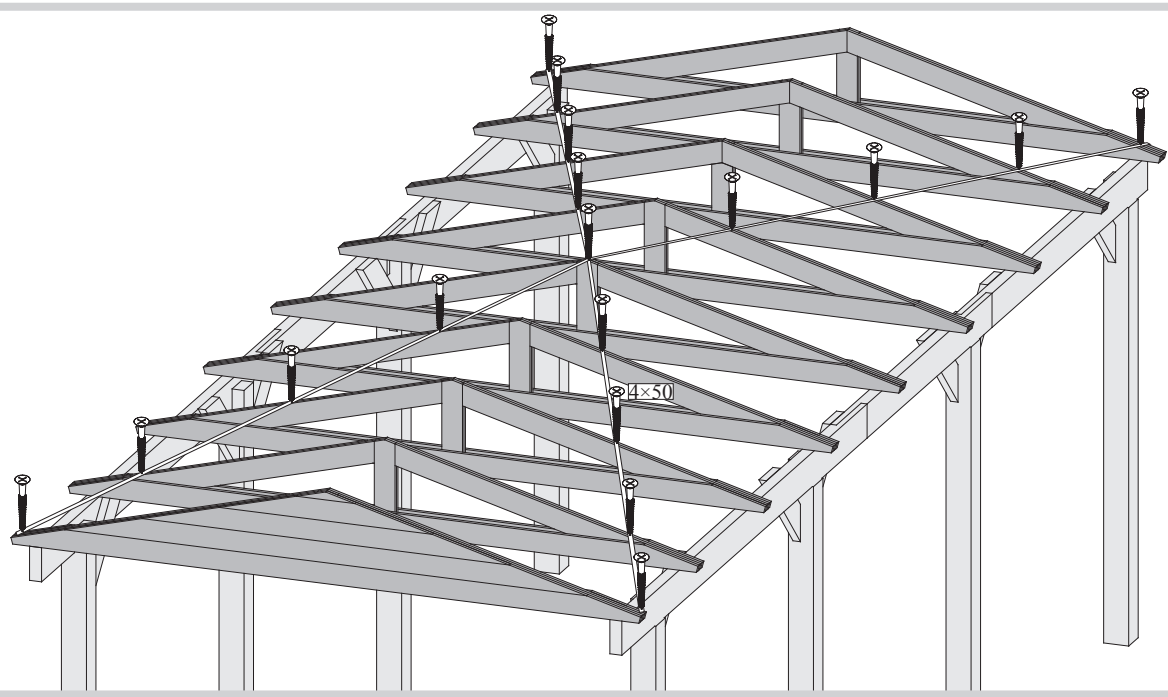

21

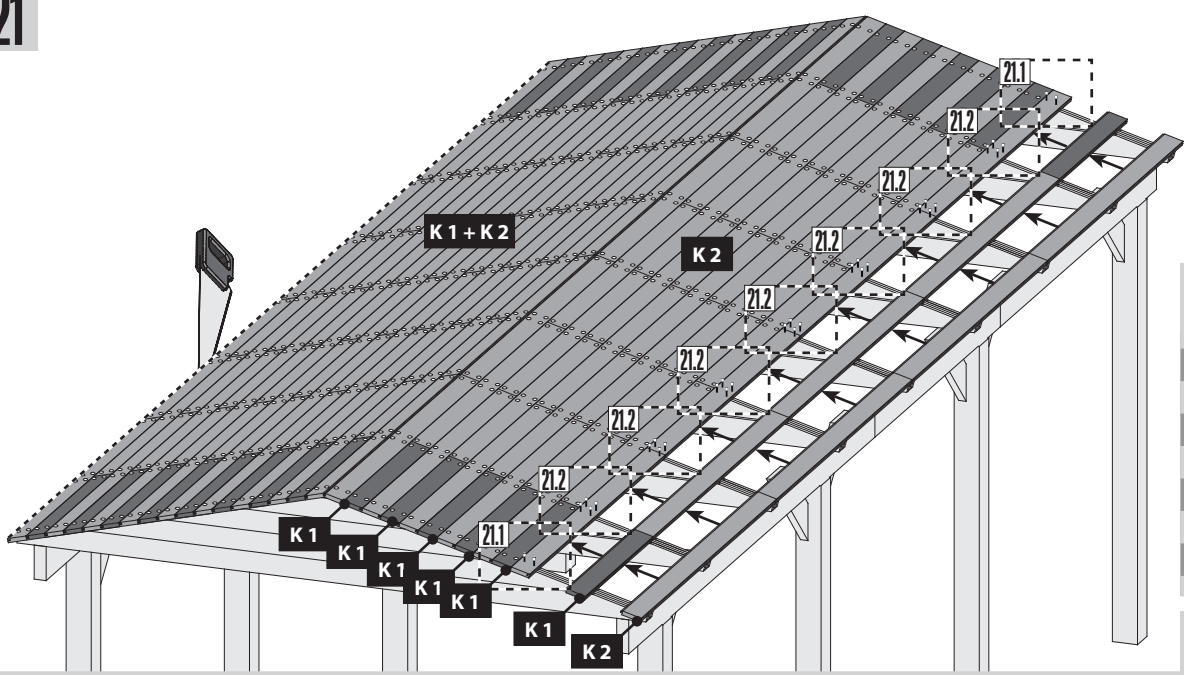

21.1

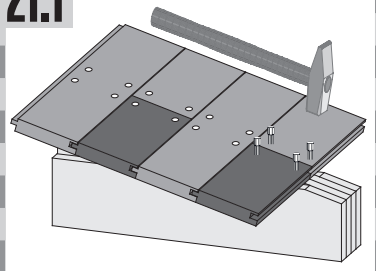

21.2

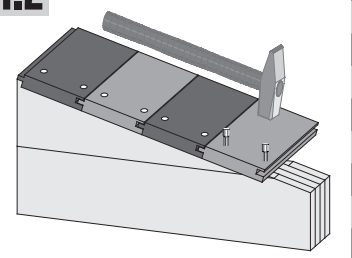

22

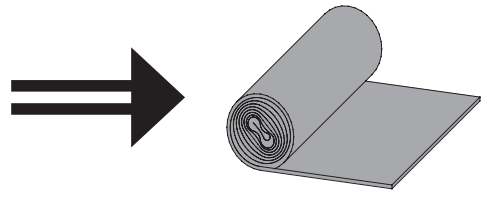

 **Achtung, dies ist nur ein Verlegebeispiel.** Die Anzahl der Dachpappbahnen richtet sich nach Ihrer Hausgröße. Stöße von Dachpappe während einer Bahn sind mit einem Überschlag von 10cm der Dachpappe durchzuführen. Bei Verwendung von nur 4 Bahnen keine Firstbahn verwenden, seitliche Bahnen mit über den First legen.

Das Dach ist nicht begehbar. Die Konstruktion ist für eine Gesamtbelastung (Schnee, Wind) und nicht für eine Punktbelastung ausgelegt. Zur Montage empfehlen wir eine bauseitige Abstützung des Daches von unten.

Wenn Sie ein **Haus mit Satteldach** haben, sollten Sie bei der Verwendung von Schindeln keine Voreindeckung mit Dachpappe vornehmen. Hier wird nur an beiden Traufseiten ein 20cm breiter Streifen Dachpappe mit Überstand verlegt (Bild 02.2 unten).

Bei **Häusern mit Tonnendach** verlegen Sie bitte Dachpappe unter die Schindeln. Damit Sie lange Freude an Ihrem Gartenhaus haben, sollten Sie diese Dacheindeckung nach 2 Monaten erneuern.

 **Attention, il s'agit uniquement d'un exemple de pose.** Le nombre de bandes de carton bitumé dépend de la taille de la maison. La jointure du carton bitumé sur une bande doit être réalisée avec une superposition de 10 cm. Si 4 bandes seulement sont utilisées, ne pas avoir recours à une bande de faite, appliquer les bandes latérales sur le faite.

Ne pas marcher sur le toit ! La construction peut supporter une charge répartie sur sa totalité (neige, vent), et non concentrée sur un point précis. Lors du montage, il vous est recommandé d'étayer le toit par en dessous.

Si votre maison possède **un toit en bâtière**, ne pas poser de couverture préalable en carton bitumé pour les couvertures en bardeaux. Pour les **maisons avec toit en berceau**, poser du carton bitumé sous les bardeaux. Pour profiter le plus longtemps possible de votre maison de jardin, renouveler la couverture du toit tous les deux meses.

 **Note! This description is only an example.** The number of required rolls of roofing felt depends on the actual size of the summer house. When joining rolls of roofing felt end to end, the overlap must be 10 cm. When using just 4 rolls of roofing felt, always cover the horizontal ridge beam with the rolls from both sides.

The roof is not safe to walk on. The roof is designed for a total load (snow, wind) and not for a point load. We recommend you to always support the roof from below during installation.

When using shingles to cover a **house with a gable roof**, never use roofing felt as a preliminary covering. Always install the roofing felt underneath the shingles for **houses with an arched roof**. To ensure maximum enjoyment of your summer house, renew the roof covering after two month.

 **Let op, dit is slechts een montagevoorbeeld.** Het aantal dakviltbanen is afhankelijk van de grootte van uw huis. Voegen van dakvilt tijdens een baan dienen met een overlapping van 10cm uitgevoerd te worden. Bij gebruik van slechts vier banen geen firstbaan gebruiken, banen aan de zijkant ook over de first leggen.

Het dak is niet beloopbaar. De constructie is ontworpen voor een totaalbelasting (sneeuw, wind) en niet voor een puntbelasting. Voor de montage adviseren we te voorzien in een zelf aan te brengen steun voor het dak van onderen.

Wanneer u een **huis met zadeldak** hebt, zou u bij het gebruik van dakshingles geen voorafdekking met dakvilt moeten aanbrengen. Bij **huizen met een boogdek** dient u dakvilt onder de shingles aan te brengen. Om lang plezier van uw tuinhuisje te hebben, zou u deze dakafdekking na twee manden vervangen.

 **Cuidado, éste es sólo un ejemplo de instalación.** La cantidad de tiras de tela asfáltica depende del tamaño de su caseta. Las juntas de tela en una tira se realizan solapando la tela asfáltica 10 cm. Cuando sólo se empleen cuatro tiras no se debe utilizar ninguna tira de cumbrera, sino colocar las tiras laterales sobre la cumbrera.

El techo no es transitable. La construcción está preparada para cargas totales (nieve, viento) y no para cargas puntuales. Para el montaje se recomienda apuntalar el techo por debajo.

Si tiene una casa con **tejado a dos aguas**, en caso de utilizar cubierta de ripias no se debería cubrir previamente con tela asfáltica. En las casas **con tejado en forma de tonel**, por favor coloque la tela asfáltica debajo de la cubierta de ripias. Para disfrutar de su caseta de jardín durante mucho tiempo se aconseja renovar la cubierta del tejado cada 2 meses.

 **Attenzione, questo è solo un esempio di posa!** La quantità dei rulli di cartone catramato dipende dalle dimensioni della casa. Le congiunzioni del cartone catramato in una corsia vanno con una sovrapposizione di 10 cm dei due pezzi di cartone catramato. Se si impiegano 4 file non disporre una sul colma ma far passare un bordo oltre il colmo stesso.

Non salire sul tetto. La costruzione è progettata per un carico diffuso (neve, vento) e non per una concentrazione puntuale del peso. Per il montaggio si consiglia un supporto del tetto con una costruzione posta sotto di esso.

Se si utilizza la **scandola per rivestire il tetto**, non si dovrebbe utilizzare il rivestimento in cartone catramato. Per **case con tetto a botte**, posare il cartone catramato sotto la scandola. Per garantire una lunga durata della casetta da giardino, è necessario rinnovare la copertura del tetto ogni 2 mesi.

01

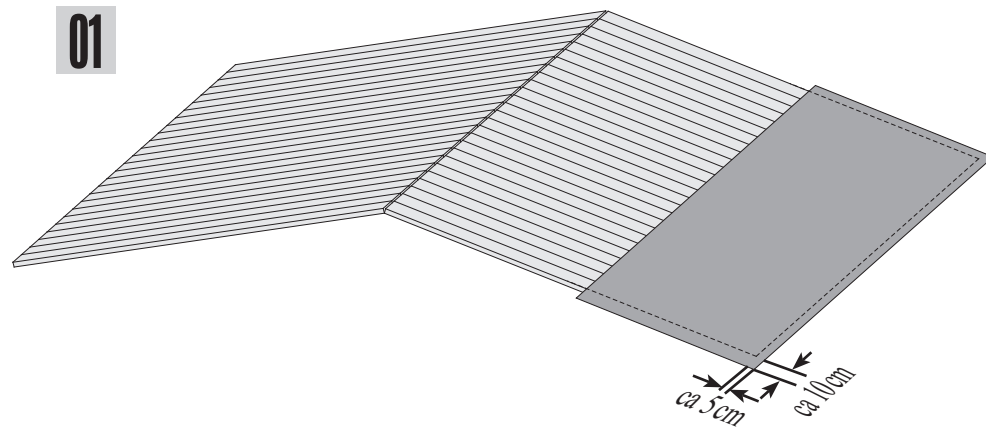

02

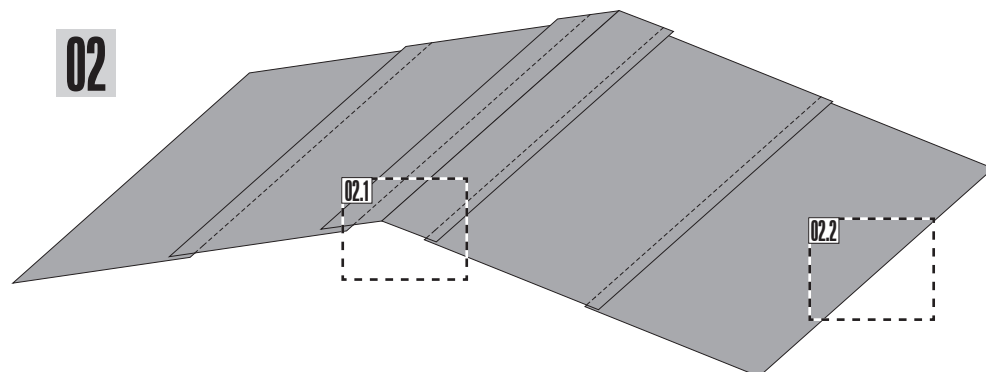

02.1

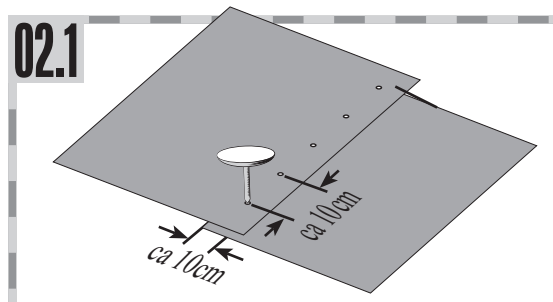

02.2

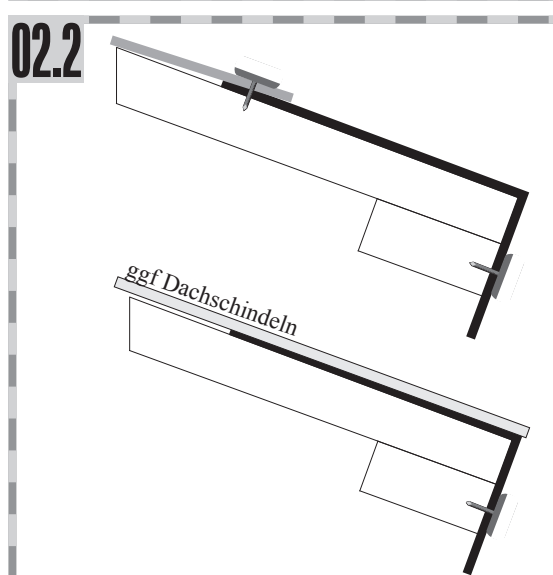

23 2x

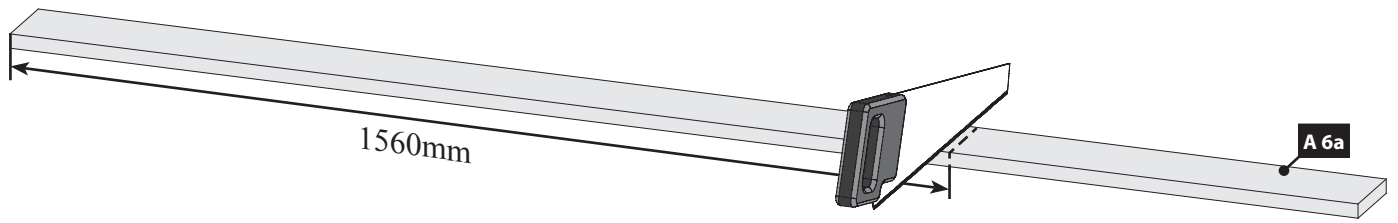

24

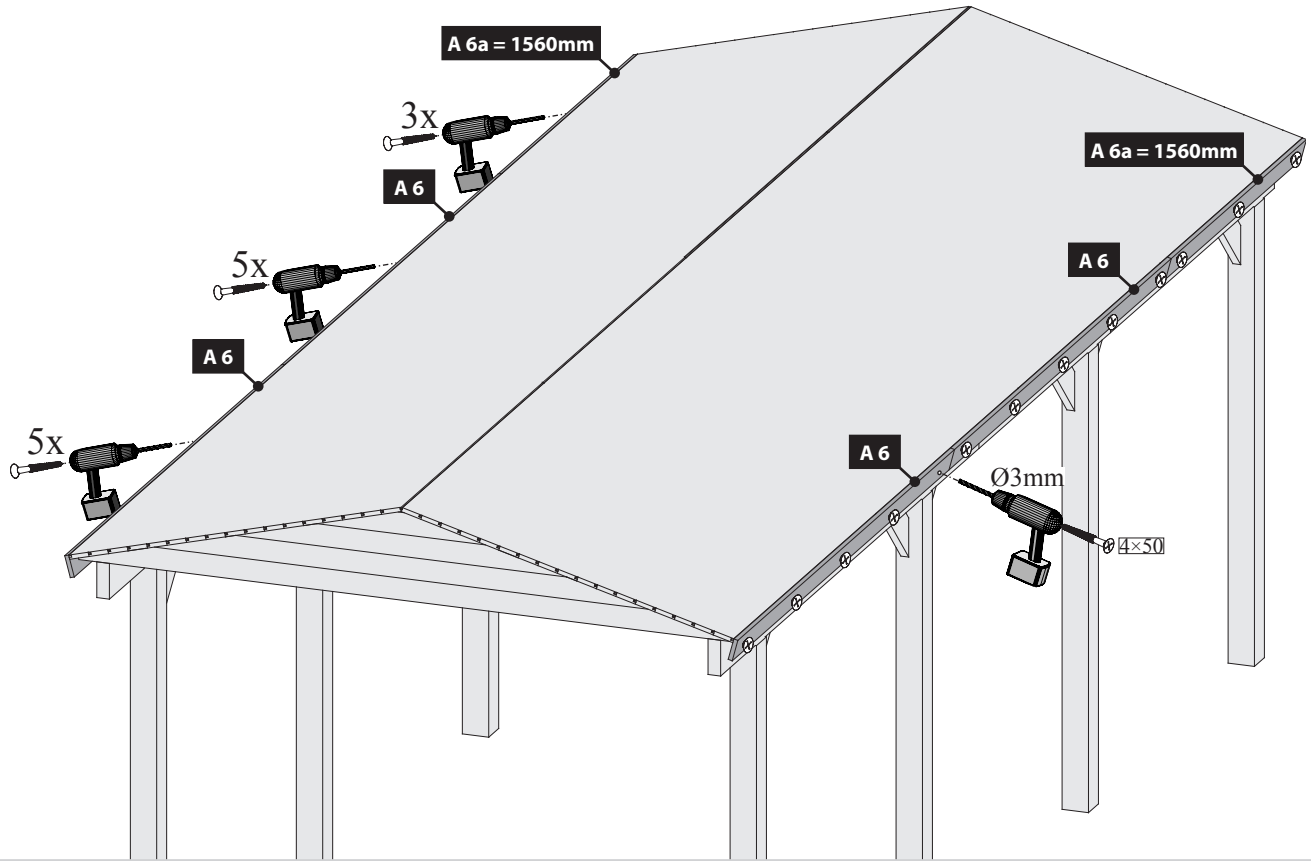

25

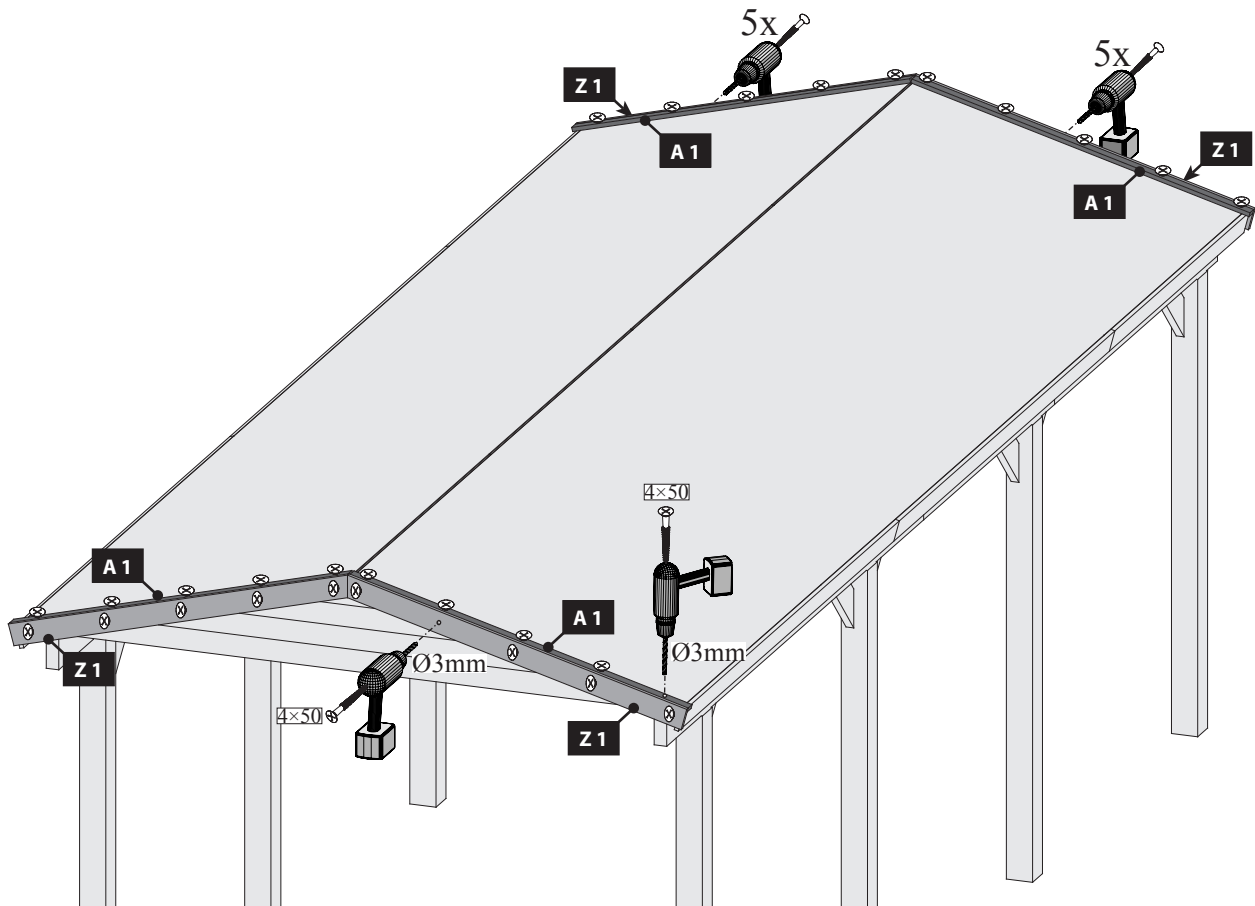

 H-Pfostenanker montieren

 Install concrete anchors

 Anclas concretas instalan

 Ancres de béton installer

 Betonankers installeren

 Ancora di calcestruzzo installano



1. Eine Grube für jeden Pfosten ausheben.
Creusez un trou pour chaque montant.
Dig a hole for each column.
Een put voor elke staander graven.
Cavar un agujero por cada poste.
Creare un foro per ogni montante.



2. Der H-Pfostenanker kann auf dem Brett in seiner Lage noch verändert werden.
Les parties métalliques inférieures des montants peuvent encore être ajustées en fonction de leurs position respective sur les liteaux.
The position of the column joists can be altered due to their position on the plank.
De staanderdraggers kunnen door de positie op de plank qua positie nog veranderd worden.
La posición de los portapostes puede variarse a su posición mediante la posición sobre la tabla.
Le parti metalliche possono essere ancora aggiustate in funzione della loro posizione rispettiva sopra la tavola.



3. Das Holzprodukt aufstellen. Die Pfosten in die H-Pfostenanker stellen. Etwas Abstand zwischen Pfostenende und Metall lassen. Die Pfosten durchbohren um sie mit den H-Pfostenankern zu verschrauben.

Positionnez le pavillon. Placez les montants dans leurs parties métalliques inférieures. Percez les montants afin de pouvoir ensuite les fixer et les visser aux parties inférieures métalliques.

Position the pavilion. Insert the columns into the joists in the process. Drill holes in the columns in order to connect them to the joists by means of screws.

Het paviljoen opstellen. De staanders daarbij in de staanderdraggers stellen. Om de staanders met de dragers vast te schroeven, moeten de staanders doorgeboord worden.

Colocar el pabellón. Colocar los postes en los portapostes. Perforar los postes para poderlos atornillar con los portapostes.

Posizionare il padiglione. Piazzare i montanti nelle loro parti metalliche. Per collegare i montanti con le parti metalliche è necessario perforare i montanti.



4. Eine Maschinenschraube vorsichtig durch die Öffnung des H-Pfostenankers einschlagen bis sie auf der anderen Seite wieder austritt.

Introduisez doucement dans le trou de la partie métallique, à l'aide d'un marteau, une vis d'assemblage à écrou, et cela jusqu'à ce qu'elle apparaisse de l'autre côté.

Carefully drill a drill screw through the opening in the concrete anchor and into the wood until the screw comes out the other side.

Een machineschroef voorzichtig door de opening van het betonanker in het hout inslaan tot ze op de andere zijde naar buiten treedt.

Introducir por percusión cuidadosamente un bulón ordinario en la madera a través de la apertura del anclaje de hormigón hasta que salga por el otro lado. Después aplanar el hormigón.

Introdurre, facendo attenzione, una vite d'assemblaggio nel foro dell'ancora di calcestruzzo nel legno fino a quando essa non fuoriesce dall'altra parte.

 H-Pfostenanker montieren

 Install concrete anchors

 Anclas concretas instalan

 Ancres de béton installer

 Betonankers installeren

 Ancora di calcestruzzo installano



5.
Die Schraube mit Mutter und 2 Unterlegscheiben fixieren.
Vissez et serrez les vis à l'aide de boulons.
Attach nuts to the screws.
De schroeven met moeren fixeren.
Fijar los tornillos con las tuercas.
Fissare le viti con l'aiuto dei bulloni.



6.
Füllen Sie Beton in das ausgegrabene Loch. Der H-Pfostenanker bleibt weiterhin mit der Leiste fixiert. Danach den Beton glattstreichen.
Remplissez les trous creusés à l'aide de béton. Les parties inférieures métalliques des montants doivent encore rester maintenues en place à l'aide des liteaux. Nivelez ensuite le béton.
Fill the holes you have dug with concrete. The concrete anchor remains attached to the slat. Then, smooth out the concrete.
Giet beton in de put. Het betonanker blijft verder met de lijst gefixeerd. Daarna de beton gladmaken.
Llene el agujero cavado con hormigón. El anclaje de hormigón continúa fijado con el listón.
Riempire il foro incavato con del calcestruzzo. L'ancora in calcestruzzo continua a rimanere fissata con il listello. Livellare in seguito il calcestruzzo.



7.
Fertig einbetonierter Pfosten.
Montant installé et bétonné.
The posts are completely set in concrete.
Klaar ingebetonnerde staander.
Poste hormigonado acabado.
Montante installato e gettato nel calcestruzzo.